

FW
P3.00

HW
04

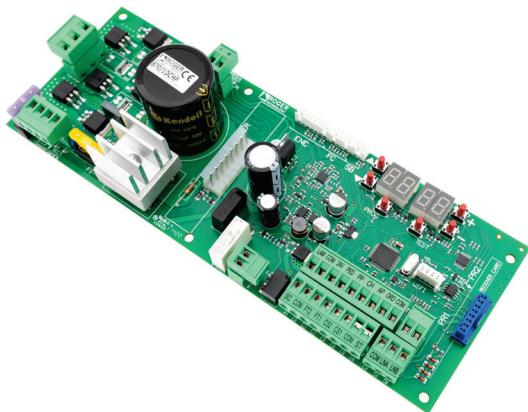

IS142 Rev.20 18/12/2025

B70/1DCHP

centrale di comando 36Vdc per cancelli scorrevoli

Istruzioni originali



- IT - Istruzioni ed avvertenze per l'installatore
- EN - Instructions and warnings for the installer
- DE - Anweisungen und Hinweise für den Installateur
- FR - Instructions et consignes pour l'installateur
- ES - Instrucciones y advertencias para el instalador
- PT - Instruções e advertências para o instalador
- NL - Aanwijzingen en waarschuwingen voor de installateur
- PL - Instrukcja i ostrzeżenia dla instalatora



3

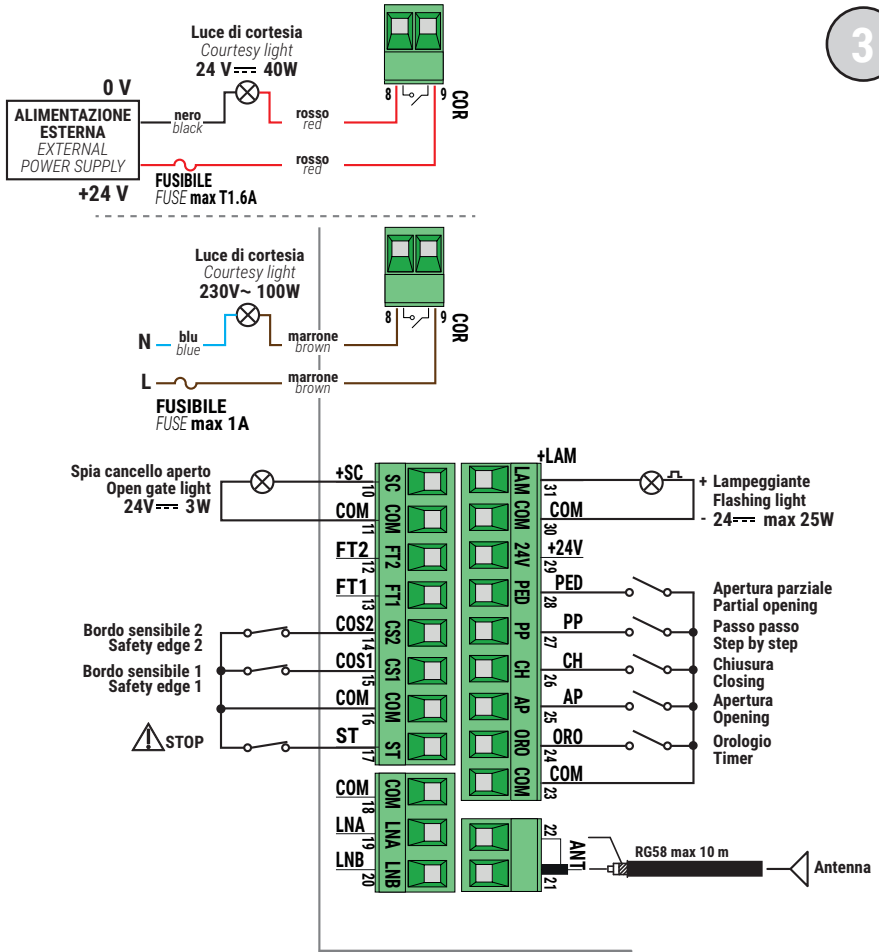

4

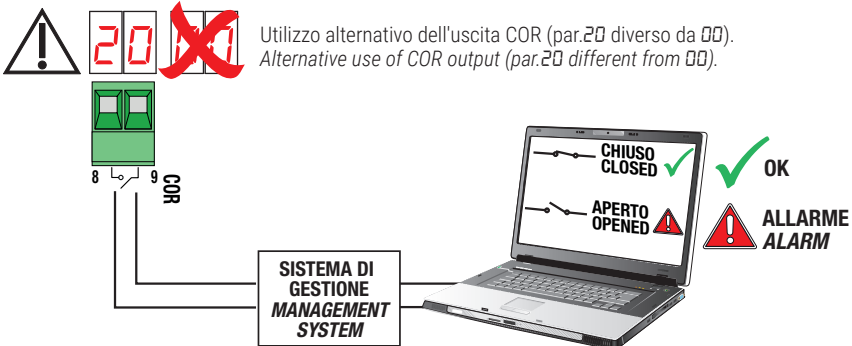

L'utilizzo è possibile solo disabilitando la modalità low-power (L 1 00)
Use is only possible by disabling low-power mode (L 1 00)

TEST FOTOCELLE · PHOTOCELLS TEST (AB 02)

COLLEGAMENTO CON 1 COPPIA FOTOCELLE SINCRONIZZATE (MODALITÀ NORMALE, SOLO COPPIA MASTER) CONNECTION WITH 1 SYNCHRONISED PHOTOCCELL PAIR (NORMAL MODE, MASTER PAIR ONLY)

ROSSO = libero da jumper
RED = jumper free

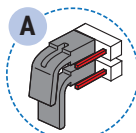
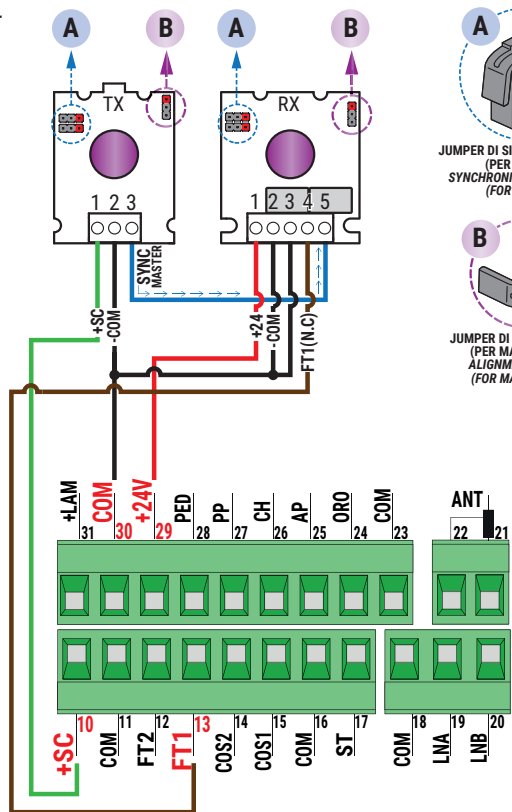

JUMPER DI SINCRONIZZAZIONE (PER MASTER)
SYNCHRONISATION JUMPER (FOR MASTER)

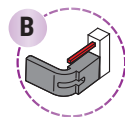

JUMPER DI ALLINEAMENTO (PER MASTER) OFF*
ALIGNMENT JUMPER (FOR MASTER) OFF*

* Per eseguire la modalità in di allineamento ottico
(NOTA: consultare le istruzioni delle fotocelle):
* To perform optical alignment mode
(NOTE: refer to photocell instructions):

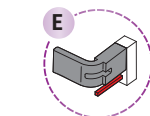
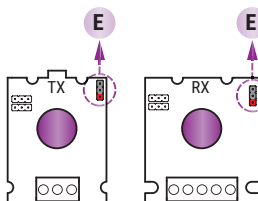

JUMPER DI ALLINEAMENTO ON*
ALIGNMENT JUMPER ON*



ATTENZIONE! Modificare la posizione dei jumper di sincronizzazione o di allineamento solamente quando le fotocelle sono **NON ALIMENTATE!** La configurazione scelta con i jumper viene memorizzata dalle fotocelle solamente all'accensione delle fotocelle.

Scollegare la morsetteria della centrale che fornisce alimentazione alle fotocelle, oppure togliere completamente la tensione al controller digitale (scollegando, se presenti, anche le batterie di backup) e verificare nella fotocella TX / RX che il LED rosso di alimentazione sia spento; procedere soltanto ora all'impostazione della configurazione dei jumper.

ATTENTION! Please ensure that the photocell jumpers are only changed with the power to the control panel switched off, including the disconnection of any battery backup. Remove the terminal of the photocell inputs or completely remove the voltage from the digital controller (check that the digital controller is not powered by backup batteries) and check that the TX / RX photocell red power LED is off.

SI RACCOMANDA L' USO DI fotocelle Serie **F4ES - F4S** / **RECOMMENDED USE for** Series **F4ES - F4S** photocells

ATTENZIONE! Il presente manuale è destinato esclusivamente a personale qualificato; leggere attentamente le avvertenze generali consegnate unitamente al presente manuale.



ATTENZIONE! la radio ricevente H93/RX2LP/I è completamente compatibile con le radio riceventi H93/RX20/I - H93/RX22A/I- H93/RX2RC/I, integrando il funzionamento con decodifica a codice fisso oppure "rolling code" (configurabile).

Per ulteriori informazioni riguardo la modalità LOW POWER consultare il manuale di B70/MODLP e il capitolo 9.4 Modalità Stand By.

Per ulteriori informazioni riguardo la modalità MASTER/SLAVE consultare il manuale di MASTER/SLAVE scaricabile dal sito www.rogertechnology.it nella sezione DOCUMENTAZIONE --> CENTRALI DI COMANDO.

1 Simbologia

Qui di seguito indichiamo i simboli e il loro significato presenti sul manuale o sulle etichette prodotto.

	Pericolo generico. Importante informazione di sicurezza. Segnala operazioni o situazioni in cui il personale addetto deve prestare molta attenzione.
	Pericolo tensione pericolosa. Segnala operazioni o situazioni in cui il personale addetto deve prestare molta attenzione a tensioni pericolose.
	Informazioni utili. Segnala informazione utili all'installazione.
	Consultazione Istruzioni di installazione e d'uso. Segnala l'obbligo di consultazione del manuale o documento in originale, che deve essere reperibile per futuri utilizzi e non deve in alcun modo essere deteriorato.
	Punto di collegamento della messa a terra di protezione.
	Indica il range di temperature ammesso.
	Corrente alternata (AC)
	Corrente continua (DC)
	Simbolo per lo smaltimento del prodotto secondo la direttiva RAEE.

2 Descrizione prodotto

La centrale di comando digitale **B70/1DCHP** a 36 V utilizza il controllo di potenza motore in modalità sensored, avvalendosi di un encoder ad alta risoluzione, per gestire le automazioni BG30 ROGER Brushless per un'anta scorrevole.

 **Attenzione all'impostazione del parametro A1. Una errata impostazione può causare anomalie nel funzionamento dell'automazione.**

Avvalendosi del dispositivo B70/MODLP collegato mediante cablaggio a 3 fili al ricevitore H93/RX2LP/I, la centrale controlla lo stato di funzionamento entrando dopo un tempo di inattività prestabilito nella modalità "low power".

ROGER TECHNOLOGY declina qualsiasi responsabilità derivante da un uso improprio o diverso da quello per cui è destinato ed indicato nel presente manuale.

Si consiglia l'uso di accessori, dispositivi di comando e di sicurezza ROGER TECHNOLOGY. In particolare, si raccomanda di installare fotocellule serie **F4ES** oppure **F4S**.

 Per ulteriori informazioni consultare il manuale del **BG30**.

3 Aggiornamenti versione P3.00

1. Aggiunta la gestione della modalità "low power", gestita dal nuovo parametro L I; tale modalità richiede l'utilizzo del ricevitore H93/RX2LP/I collegato a B70/MODLP
2. Aggiunto parametro L0 per abilitare/disabilitare B-CONNECT
3. Aggiunto parametro 50 per configurare il tipo di fincorsa utilizzato
4. Aggiunte nuove segnalazioni a display "5Lb5", "RcL i" e "noLP" relative alle situazioni di funzionamento nella gestione low-power
5. Aggiunto parametro RD per abilitare la gestione della modalità MASTER/SLAVE per automazioni contrapposte

9.2 Command and safety device status display mode

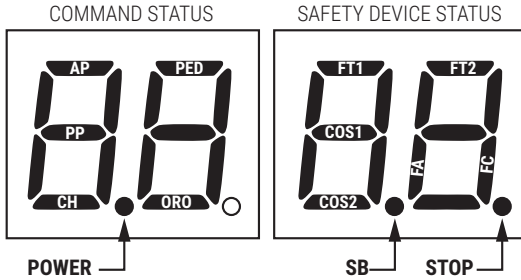

COMMAND STATUS:

The command status indicators on the display are normally OFF.

They ILLUMINATE when a command is received (e.g.: when a step mode command is received, the segment PP illuminates).

SEGMENT	COMMAND
<i>AP</i>	open
<i>PP</i>	step-by-step mode
<i>CH</i>	close
<i>PEd</i>	partial opening
<i>OR</i>	clock

SAFETY DEVICE STATUS:

The safety device status indicators ON the display.

If an indicator is OFF, the relative device is in alarm state or is not connected.

The an indicator is FLASHING, the relative device has been disabled with a specific parameter.

SEGMENT	SAFETY
<i>FT1</i>	FT1 photocells
<i>FT2</i>	FT2 photocells
<i>COS1</i>	COS1 sensing edge
<i>COS2</i>	COS2 sensing edge
<i>FA</i>	gate open limit switch
<i>FC</i>	gate closed limit switch
<i>Sb</i>	release handle open
<i>STOP</i>	STOP

9.3 TEST mode

The TEST mode is used to test activation of the commands and safety devices with visual confirmation. To activate the mode, press the TEST button with the automatic door system at rest. If the gate is moving, pressing TEST stops the gate. Pressing the button again enables TEST mode. If the flashing light and the gate open indicator lamp illuminate for one second each time a control is used or a safety device is activated.

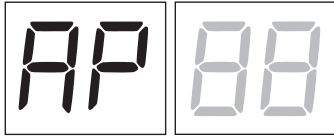

The command signal status is shown on the left hand side of the display for 5 seconds, ONLY when the respective command signal is active (AP, CH, PP, PE, OR). For example, if the gate open command is activated, the letters AP appear on the display.

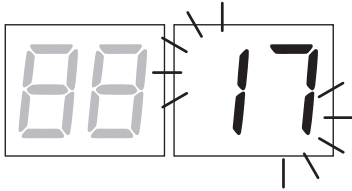

The status of the safety devices/inputs is shown on the right hand side of the display. The number of the terminal relative to the safety device in alarm state flashes.

When the gate is completely open or completely closed, FR or FC is shown on the display to indicate that the gate has reached the gate open limit switch FR or gate closed limit switch FC.

Example: STOP contact in alarm state.

00	No safety device in alarm state and no limit switch activated.
5b (Sb)	Release handle or lock open.
17	STOP contact (N.C.) open. If there is no STOP switch, jumper the contact.
15	Sensing edge contact COS1 (N.C.) is open. Check connection. If sensing edge is not installed, disable with 7300.
14	Sensing edge contact COS2 (N.C.) is open. Check connection. If sensing edge is not installed, disable with 7400.
13	Photocell contact FT1 (N.C.) is open. Check connection. If photocell is not installed, disable with 5000.
12	Photocell contact FT2 (N.C.) is open. Check connection. If photocell is not installed, disable with 5300.
FE	Both limit switches in error state. Check connections and settings of limit switches.
FR	If gate is open, gate open limit switch is detected.
FC	If gate is closed, gate closed limit switch is detected.
nC	If par.AD is not 00 (RS485 communication enabled), this indicates no communication.

NOTA: If one or more contacts are open, the gate will not open or close. This does not apply for the limit switch signal state, however, which is shown on the display but does not prevent normal operation of the gate.

If more than one safety device is in alarm state, once the problem relative to the first device is resolved, the alarm for the next device is displayed. Any further alarm states are also displayed with the same logic.

Press the TEST button again to exit test mode.

After 10 seconds with no user input, the display returns to command and safety device state display mode.

If you are viewing the MASTER control unit (par.AD=0 1) of an installation with opposing doors (MASTER/SLAVE), the safety number activated on the SLAVE control unit appears with two decimal points lit (example: STOP active on MASTER displays '15', STOP active on SLAVE displays '1.5').

Similarly, when consulting the SLAVE control panel display (par.AD=02 or 03), the security number activated on the MASTER will have two decimal points lit (indicating 'remote security activation', i.e. connected to the twin control panel).

For further information on MASTER/SLAVE mode, refer to the MASTER/SLAVE manual, which can be downloaded from the website www.rogertechnology.it in the DOCUMENTATION --> CONTROL UNITS section.

9.4 Standby mode

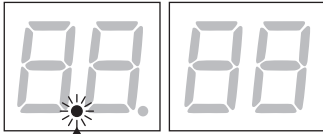

There are two possible stand-by situations:

1. The one that simply turns off the display, leaving only the LED POWER flashing: this is activated after 30 min of inactivity and is only possible if low power management (L 100) is not enabled

2. The one that brings the power consumption of the control unit to a value ≤ 0.5 W, by default it is set to activate after 20 minutes of inactivity (L 104) but

with a parameter value of 0, 1, 02, 03 it can be set to 5-10-15 minutes of inactivity.

In this operating situation, the transformer is not powered, and only the logic section of the control unit, powered by the B70/MODLP module, remains in operation.

The 24V output of the control unit is therefore not powered, with the following consequences:

- it is not possible to use an external receiver, unless this is powered by a source external to the control unit
- it is not possible to use certain command modes based on the crossing of the photocells, as the photocells are also not powered; reference to the settings of parameters 52 and 55 (to command opening) and 56 (to have reclosing after 6 seconds)

Other consequences:

- it is not possible to have backup batteries, as in stand-by they would not receive a charge (not even the maintenance charge) and above all, lacking the alternating transformer voltage (due to its shutdown operated by B70/MODLP) would activate the power supply from the battery ("bAtt" on the display), discharging it unnecessarily. To use the batteries it is compulsory to disable the "low power" mode (L 100)
- it is not possible to use B-CONNECT, because in stand-by the control unit does not communicate with it therefore it does not provide information nor does it allow the control unit to be controlled. To use B-CONNECT you must disable the "low power" mode (L 100).

The "low power" stand-by time countdown is managed as follows:

- resets when a command is received and as long as the drive is in motion
- resets if the drive is paused for reclosing (parameters R2 and 2 1), as this is still an active phase of the drive
- resets if the guaranteed reclosing countdown is running (par.B2)
- resets if the COR output timing is in operation
- resets when one of the keys around the display is activated

Only at the end of the situations listed above does the countdown begin, which at the end of the time (selected in parameter L 1) leads to the "low power" stand-by phase.

The display shows "5E6Y" and after 1.5" turns off the display and deactivates the SC, LAM and COR outputs.

To activate stand-by without having to wait and be able to test the "low power" operation:

simultaneously activate the 4 buttons: UP ▲, DOWN ▼, + and - for about a second and a half: you will hear the relay switch inside the B70/MODLP and the display will show "5E6Y".

If for some reason the B70/MODLP fails to disconnect power to the transformer, "noLP" will appear on the central unit display after approximately 8 seconds, indicating that the "low power" has not been activated.

Exit from the stand-by mode occurs in one of the following ways:

- upon activation of a terminal board command (AP, CH, PP, PE, OR)
- upon activation of a radio command
- upon activation of one of the buttons PROG, TEST

Waking up from stand-by is indicated by the display message "RcE r", which signals the reactivation of the control unit.

Attention! Reactivation involves re-powering the transformer, i.e. the return of the 24 V power supply to the control unit: the reaction to a command is slightly delayed as one has to wait for a time to stabilise the operation of the photocells and to be able to assess whether they are in alarm or not.



10 Travel acquisition

i For the system to function correctly, the gate travel must be acquired by the control.

10.1 Before starting

1. Select the automation system model installed with the parameter *R 1*.

KEY:  **HIGH SPEED Motor**  **REVERSIBLE Motor**

SELECTION	MODEL	MOTOR TYPE	CONFIGURATIONS
<i>R 1 01</i>	BG30/1600	-	up to 1600 kg
<i>R 1 02</i>	BG30/2200	-	up to 2200 kg
<i>R 1 03</i>	BG30/1000/HS		up to 1000 kg <i>see chapter 13 "Special Parameters for High Speed Motor"</i>
<i>R 1 04</i>	BG30/1400/R		up to 1400 kg <i>see chapter 14 "Special Parameters for Reversible Motor"</i>
<i>R 1 05</i>	BG30/1800/HS		up to 1800 kg <i>see chapter 13 "Special Parameters for High Speed Motor"</i>
<i>R 1 06</i>	BG30/1500/HS		up to 1500 kg <i>see chapter 13 "Special Parameters for High Speed Motor"</i>
<i>R 1 07</i>	BG30/804/HS		up to 800 kg <i>see chapter 13 "Special Parameters for High Speed Motor"</i>



2. Select the position of the motor relative to the gate with the parameter *7 1*. The default setting for this parameter is with the motor installed on the right hand side of the gate (seen from interior side).

OPENING ON THE LEFT 



OPENING ON THE RIGHT 



3. Adjust the (mechanical or magnetic) limit switches so that, once triggered, the gate stops slightly before it reaches the mechanical stop.

CLOSING LIMIT SWITCH 

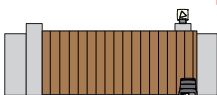

OPENING LIMIT SWITCH 

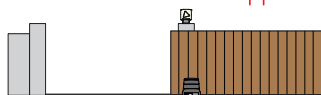

4. Check that the operator present function is not enabled (*R7 00*).

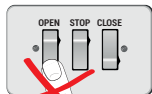

5. Move the gate into the closed position.

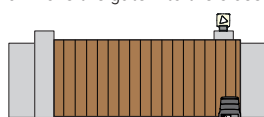

6. Press **TEST** (see TEST mode in chapter 9) and check the command signal and safety device states. If any safety devices are not installed, jumper the relative contact or disable the device from the relative parameter (*50, 5 1, 53, 54, 73 and 74*).

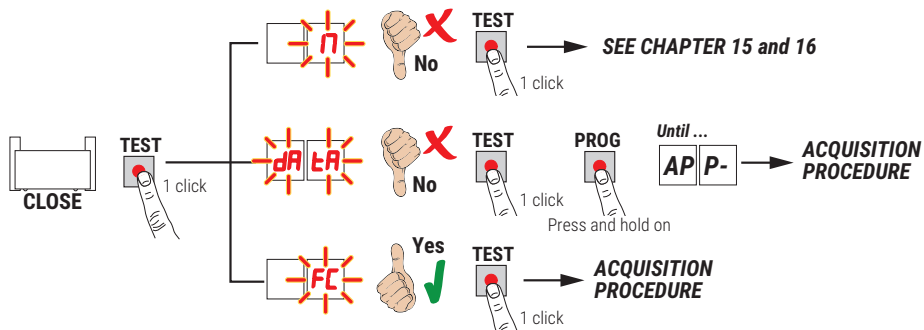

10.2 Acquisition procedure

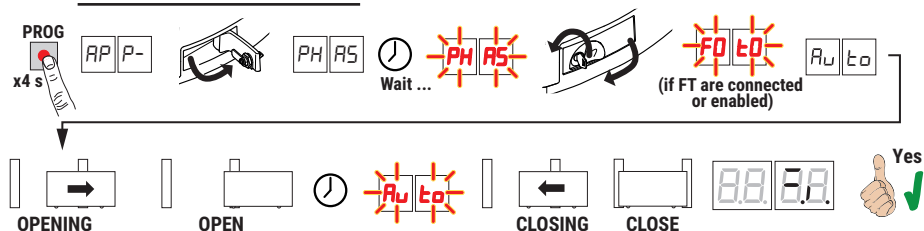

- Press and hold **PROG** for 4 seconds. *AP P-* is shown on the display.
- Open the release handle. The message *PH AS* appears on the display after a few seconds. The controller unit launches a calibration procedure. The operating parameters of the motor are determined during calibration.
- If the motor calibration procedure is successful, the message *PH AS* flashes on the display.
- Close the release handle. The acquisition procedure now starts.
- *FD ED* is shown on the display (only if parameters *S0, S 1, S3, S4* are not disabled). Keep away from the photocell beam within 5 s, to prevent interrupting the procedure.
- *Au tO* is shown on the display and the gate starts opening at low speed.
- The gate stops briefly when it reaches the gate open limit switch. *Au tO* flashes on the display.
- The gate closes until it reaches the gate closed limit switch.

If the acquisition procedure is completed successfully, the display enters the command and safety device state display mode.



If the following error messages are shown on the display, repeat the acquisition procedure:

- *n* *PH*: calibration procedure failed.
- *AP PE*: acquisition error. Press the **TEST** button to clear the error, and check the safety device in alarm state.
- *AP PL*: travel length error. Press the **TEST** button to clear the error, and check that gate is completely closed.

ATTENTION: if the acquisition procedure was successful **BUT** the space between the leaf (stopped at the limit switch) and the mechanical stop is not as desired, move the limit switch and **REPEAT THE ACQUISITION PROCEDURE**. Ensure that **AT LEAST 3** centimetres remain between the leaf stop and the mechanical stop.

i For more information, see chapter 16 "Alarms and faults".

11 Parameter's index

PARAM.	FACTORY VALUE	DESCRIPTION	PAGE
R0	00	Enable RS485 serial communication (MASTER-SLAVE)	67
R1	see chap. 10	Selecting automation system model	67
R2	00	Automatic closure after pause time (from gate completely open)	67
R3	00	Automatic gate closing after mains power outage	67
R4	00	Selecting step mode control function (PP)	68
R5	00	Pre-flashing	68
R6	00	Condominium function for partial open command (PED)	68
R7	00	Enabling operator present function	68
R8	00	Gate open indicator / photocell test function and "battery saving"	68
11	04	Setting deceleration during opening (and closing for BG30/1600 - BG30/2200)	68
12	04 	Setting deceleration during closing (High Speed and Reversible Motors only)	68
13	02	Setting gate open limit switch constant speed approach distance	68
14	02	Setting gate closed limit switch constant speed approach distance	68
15	50	Partial opening adjustment (%)	68
16	00	Adjusting automatic closing time after partial opening	69
20	00	Type of signaling provided by COR output	69
21	30	Setting automatic closing time	69
22	00	Enabling of management for opening with automatic re-closure exclusion	69
27	03	Setting reverse time after activation of sensing edge or obstacle detection (crush prevention)	69
30	05	Setting motor torque	69
31	15	Setting obstacle impact force sensitivity	69
33	04	Setting start acceleration during opening (and closing for BG30/1600 - BG30/2200)	70
34	04 	Setting start acceleration during closing (High Speed and Reversible Motors only)	70
36	00	Enabling maximum torque boost at start of manoeuvre	70
37	01	Setting motor torque during position recovery	70
40	08	Setting opening speed (and closing for BG30/1600 - BG30/2200)	70
41	08 	Setting closing speed (High Speed and Reversible Motors only)	70
42	03	Setting end of manoeuvre constant approach speed	70
49	01	Setting number of automatic closure attempts after activation of sensing edge or obstacle detection (crush protection)	70
50	00	Setting photocell mode during gate opening (FT1)	70
51	02	Setting photocell mode during gate closing (FT1)	71
52	01	Photocell (FT1) mode with gate closed	71
53	00	Setting photocell mode during gate opening (FT2)	71
54	00	Setting photocell mode during gate closing (FT2)	71
55	01	Photocell (FT2) mode with gate closed	71

PARAM.	FACTORY VALUE	DESCRIPTION	PAGE
56	00	Enable close command 6 s after activation of photocell (FT1-FT2)	71
60	01	Limit switch type selection	71
65	05	Setting motor stop distance	72
70	00	Maximum stroke length selection	72
71	01	Selecting installation position of motor relative to gate (seen from interior side)	72
73	00	Configuring sensing edge COS1	72
74	00	Configuring sensing edge COS2	72
76	00	Configuring radio channel 1 (PR1)	72
77	01	Configuring radio channel 2 (PR2)	72
78	00	Configuring flashing light frequency	73
79	60	Selecting courtesy light mode	73
80	00	Clock contact configuration	73
81	00	Enable safeguarded gate closure/opening	73
82	03	Setting safeguarded closure/opening activation time	73
85	03	Selection of the battery operation management	73
86	00	Selection of the battery operation limitations	74
87	00	Selection of the battery type and consumption reduction	74
88	00	Cyclical activation (test mode)	74
89	00	Enabling parameter management of the SLAVE control unit using B74/BCONNECT inserted on the MASTER control unit	74
L0	00	Enabling serial communication	74
L1	04	"Low power stand-by" mode configuration	75
FR	00	Restoring factory default values	75
n0	01	HW version	75
n1	23	Year of manufacture	75
n2	45	Week of manufacture	75
n3	67	Serial number	75
n4	89		75
n5	01		75
n6	23		FW sequential version
n7	13	MASTER/SLAVE RS485 communication version	75
o0	01	View manoeuvre counter	75
o0	23		75
o1	45		75
h0	01	View manoeuvre hour counter	75
h1	23		75
d0	01	View control unit days on counter	76
d1	23		76
P1	00	Password	76
P2	00		76
P3	00		76
P4	00		76
CP	00	Changing password	76

12 Parameter menu

PARAMETER PARAMETER
VALUE

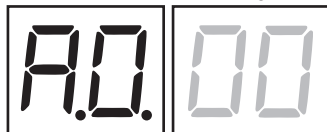

A0 00	Enable RS485 serial communication (MASTER-SLAVE) For further information on MASTER/SLAVE mode, refer to the MASTER/SLAVE manual, which can be downloaded from the website www.rogertechnology.it in the DOCUMENTATION --> CONTROL UNITS section.
00	Standard operation (no MASTER/SLAVE): single automation installation
01	MASTER/SLAVE mode enabled: the control unit acts as MASTER unit
02	MASTER/SLAVE mode enabled: the control unit acts as SLAVE unit, with a copy of the parameters set on the MASTER unit ("mirroring" the parameters) ATTENTION! Setting value 02 on the SLAVE forces the MASTER parameters to be copied to the SLAVE, with the following exceptions: - par.A0 is not changed - par.50...55 are set to disable the photocells on the SLAVE control unit: this is the case when all photocells are connected to the MASTER control unit. If some photocells are connected to the SLAVE unit instead (to make the installation simpler, e.g. those covering the blind side of the SLAVE automation movement), they must be enabled also on the SLAVE unit (see Chapters 4 and 5) - par.7 I is set to the value opposite to that of the MASTER unit Each subsequent change made to the MASTER parameters is also performed simultaneously on the SLAVE unit (*)
03	MASTER/SLAVE mode enabled: the control unit acts as SLAVE unit, with parameters completely independent of the MASTER unit; therefore, the parameters must be set on the SLAVE unit as well

(*) Some parameters may be edited manually also from the SLAVE control unit. This occurs because the two automations can have different characteristics, and therefore require different adjustments (forces, acceleration, deceleration, speed), or they could/could not be equipped with locally connected safety devices (e.g.: the sensing edge on the SLAVE automation, which is logically connected to the SLAVE control unit for ease of installation).

These parameters are: 11, 12, 20, 30, 31, 33, 34, 40, 41, 42, 50...55, 71, 73, 74

A1 01	Selecting automation system model WARNING! If this parameter is not set correctly, the automation system may not function properly. N.B.: in the event of a reset to restore the default parameters, this parameter must be set again manually. Setting values 03, 04, 05, 06, 07 disables 'low power' mode, par.L I is not displayed.	
01	BG30/1600 - IRREVERSIBLE motor for gate leaves up to 1600 Kg.	
02	BG30/2200 - IRREVERSIBLE motor for gate leaves up to 2200 Kg.	
03	BG30/1000/HS - High Speed IRREVERSIBLE motor for gate leaves up to 1000 kg (see chapter 13 "Special Parameters for High Speed Motor").	
04	BG30/1400/R - REVERSIBLE motor for gate leaves up to 1400 kg (see chapter 14 "Special Parameters for REVERSIBLE Motor").	
05	BG30/1800/HS - High Speed IRREVERSIBLE motor for gate leaves up to 1800 kg (see chapter 13 "Special Parameters for High Speed Motor").	
06	BG30/1500/HS - High Speed IRREVERSIBLE motor for gate leaves up to 1500 kg (see chapter 13 "Special Parameters for High Speed Motor").	
07	BG30/804/HS - High Speed IRREVERSIBLE motor for gate leaves up to 800 kg (see chapter 13 "Special Parameters for High Speed Motor").	

A2 00	Automatic closure after pause time (from gate completely open)
00	Disabled.
01-15	From 1 to 15 of gate closure attempts after photocell is triggered. Once the number of attempts set is reached, the gate remains open.
99	The gate tries to close indefinitely.

A3 00	Automatic gate closing after mains power outage
00	Disabled. The gate does not close automatically when mains power is restored.
01	Enabled. If the gate is NOT completely open, when mains power is restored, the gate closes after a 5 second warning signalled with the flashing light (independently of the value set with the parameter A5). The gate closes in "position recovery" mode (see chapter 20).

R4 00	Selecting step mode control function (PP)
00	Open-stop-close-stop-open-stop-close...
01	Condominium function: the gate opens and closes after the set automatic closing time. The automatic closing timer restarts if a new step mode command is received. Step mode commands are ignored while the gate is opening. This allows the gate to open completely and prevents the gate from closing when not required. If automatic closing is disabled (R2 00), the condominium function automatically attempts a closing manoeuvre R2 01.
02	Condominium function: the gate opens and closes after the set automatic closing time. The automatic closing timer does NOT restart if a new step mode command is received. Step mode commands are ignored while the gate is opening. This allows the gate to open completely and prevents the gate from closing when not required. If automatic closing is disabled (R2 00), the condominium function automatically attempts a closing manoeuvre R2 01.
03	Open-close-open-close.
04	Open-close-stop-open.
R5 00	Pre-flashing
00	Disabled. The flashing light is activated during opening and closing manoeuvres.
01-10	Flashing warning signal for 1 to 10 seconds prior to every manoeuvre.
99	5 second flashing warning signal prior to closing manoeuvre.
R6 00	Condominium function for partial open command (PED)
00	Disabled. The gate opens partially in step mode: open-stop-close-stop-open...
01	Enabled. Partial commands are ignored during gate opening.
R7 00	Enabling operator present function
00	Disabled.
01	Enabled. The open (AP) or close (CH) button must be pressed continuously to operate the gate. The gate stops when the button is released.
R8 00	Gate open indicator / photocell test function and "battery saving" NOTE: the signal given by the gate open indicator can only be used if the "low power" mode is disabled (L 1 00)
00	The indicator is off when the gate is closed, and steadily lit during manoeuvres and when the gate is open.
01	The indicator flashes slowly during opening manoeuvres, and is lit steadily when the gate is completely open. It flashes quickly during closing manoeuvres. If the gate is stopped in an intermediate position, the lamp extinguishes twice every 15 seconds.
02	Set 02 if the output SC is used for the photocell test. See fig. 7-8.
03	Set to 03 if the output SC is used for the "battery saving" function. See fig. 9-10. When the gate is completely open or closed, the controller unit deactivates any accessories connected to terminal SC to reduce battery consumption.
04	Set to 04 if the output SC is used for the "battery saving" function and photocell test function. See fig. 9-10.
11 04	Setting deceleration during opening and closing
12 04	See chapters 13 and 14
01-05	01= the gate decelerates near the limit switch ... 05= the gate decelerates long before the limit switch.
13 02	Setting gate open limit switch constant speed approach distance N.B.: the manoeuvre speed is set with parameter 42. After decelerating, the gate completes the distance to the limit switch at constant speed.
14 02	Setting gate closed limit switch constant speed approach distance N.B.: the manoeuvre speed is set with parameter 42. After decelerating, the gate completes the distance to the limit switch at constant speed.
01-40	01= last 3 cm; 02= last 6 cm; ... 40= last 120 cm. Approximate example: 100 cm distance = value 35.
15 50	Partial opening adjustment (%) N.B.: This parameter is set to 50% (half of total gate travel) by default.
10-99	From 10% to 99% of total gate travel.

16 10	Adjusting automatic closing time after partial opening The countdown starts when the pedestrian opening is reached, as defined in paragraph 15.
00-90	Pause time settable from 00 to 90 s.
92-99	Pause time settable from 2 to 9 min.
20 00	Type of signaling provided by COR output NOTE: the signal given by the COR output can only be used if the "low power" mode is disabled (L 100)
00	STANDARD operation managed by parameter 79
01	Contact closed if the control unit is working properly. Contact open if central locked in alarm.
02	Contact closed if the control unit is powered by the mains or charged battery. Open contact due to a fault; control unit powered by low battery (voltage level set by par. 85) or with error alert b&L0 (the control unit no longer accept commands).
03	Closed contact if none of the fault related situations 1 and 2 occurs. Open contact if at least one of the fault related situations 1 and 2 occurs
04	Closed contact if the gate is not completely open. Open contact if the gate is completely open.
05	Closed contact if the gate is not completely closed. Open contact if the gate is completely closed.
21 30	Setting automatic closing time The timer starts from the gate open state and continues for the set time. Once the set time is reached, the gate closes automatically. The timer count restarts if a photocell is triggered.
00-90	Pause time settable from 00 to 90 s.
92-99	Pause time settable from 2 to 9 min.
22 00	Enabling of management for opening with automatic re-closure exclusion If enabled, the exclusion of automatic re-closure only applies for the command selected via the parameter. For example: if you set 220 1, automatic re-closure is excluded following an AP command, but it is activated following a PP or PED command. NOTE: The command has open-stop-close or close-stop-open sequence activation function.
00	Disabled.
01	An AP (opening) command activates the opening manoeuvre. When the gate is fully open, automatic reclosure is excluded. A subsequent AP (open) command activates the closing operation.
02	A PP (step-by-step) command activates the opening manoeuvre. When the gate is fully open, automatic reclosure is excluded. A subsequent PP (step-by-step) command activates the closing operation.
03	A PED (partial opening) command activates the partial opening operation. Automatic reclosure is excluded. A subsequent PED (partial opening) command activates the closing operation.
27 03	Setting reverse time after activation of sensing edge or obstacle detection (crush prevention) This sets the reverse manoeuvre time after activation of the sensing edge or the obstacle detection system. The gate comes to a stop after reversal dues to activation of the sensing edge or obstacle detection system at the end of manoeuvre deceleration speed. As a result, the effective reversal manoeuvre time is slightly longer than the set time.
00-60	From 0 to 60 s.
30 05	Setting motor torque Increasing or decreasing the value of the parameter increases or decreases motor torque and, as a result, adjusts obstacle detection sensitivity. Use values below 03 ONLY for particularly lightweight installations not exposed to severe weather conditions (strong winds or very cold temperatures).
01-09	01 = -35%; 02 = -25%; 03 = -16%; 04 = -8% (reduced motor torque = increased sensitivity). 05 = default motor torque setting. 06 = +8%; 07 = +16%; 08 = +25%; 09 = +35% (increased motor torque = reduced sensitivity).
31 15	Setting obstacle impact force sensitivity If the reaction time to obstacle impact force is too long, reduce the value of the parameter. If the impact force exerted on obstacles is too high, reduce the value of parameter 30.
01-10	Low motor torque: 01 = minimum obstacle impact force ... 10 = maximum obstacle impact force N.B.: only use these settings if the medium motor torque values are not suitable for the installation.
11-16	Medium motor torque. Recommended setting for adjusting force settings correctly. 11 = minimum obstacle impact force ... 16 = maximum obstacle impact force.
17	70% of maximum motor torque, 1 s of reaction time. Sensing edge is compulsory.

18	80% of maximum motor torque, 2 s of reaction time. Sensing edge is compulsory.
19	Maximum motor torque, 3 s of reaction time. Sensing edge is compulsory.
20	Maximum motor torque, 5 s of reaction time. Sensing edge is compulsory.
33 04	Setting start acceleration during opening and closing
34 04	See chapters 13 and 14
0 1-05	0 1= the gate accelerates rapidly at start of manoeuvre ... 05= the gate accelerates slowly and progressively at start of manoeuvre.
36 00	Enabling maximum torque boost at start of manoeuvre If this parameter is enabled, each time the motor starts a manoeuvre, maximum torque is produced for a maximum of 5 seconds, or for the time necessary for the gate to open by approximately 65 cm. N.B: in the case of High Speed motors, a motor boost mode is implemented for 2 seconds after each gate start, regardless of the setting of parameter 36.
00	Disabled.
0 1	Enabled at start of opening manoeuvre only (including position recovery). The motor starting current function is only enabled for closing manoeuvres if the gate position is known and the gate is over to 2 metres from the completely closed position.
02	Enabled for all starts (including position recovery).
37 01	Setting motor torque during position recovery Adjust motor torque with parameter 37 if, during position recovery, the values set with parameters 30 and 3 1 are insufficient to allow the gate to complete the manoeuvre. If position recovery is not completed, normal gate operation will not be resumed.
00	The response of the obstacle detection system depends solely on the values set for parameters 30 and 3 1.
0 1	The response of the obstacle detection system depends on the values set for parameters 30 and 3 1 and on the maximum current value stored during travel acquisition.
02	The response of the obstacle detection system is a 70% reduction in maximum torque for a period of 1 s.
03	The response of the obstacle detection system is a 80% reduction in maximum torque for a period of 2 s.
04	The response of the obstacle detection system is a 100% reduction in maximum torque for a period of 3 s.
05	The response of the obstacle detection system is a 100% reduction in maximum torque for a period of 5 s.
40 08	Setting opening and closing speed N.B.: the speed setting range for the specific motor installed is automatically subdivided into 10 equal segments.
41 08	See chapters 13 and 14
0 1- 10	0 1= 6 m/min ... 10= maximum speed.
42 03	Setting end of manoeuvre constant approach speed Once deceleration is complete, the gate continues to the limit switch at constant speed. The distance is set with the parameters 13 and 14.
0 1-05	0 1= 2 m/min; 02= 2,5 m/min; 03= 3 m/min; 04= 3,5 m/min; 05= 4 m/min.
49 01	Setting number of automatic closure attempts after activation of sensing edge or obstacle detection (crush protection)
00	No automatic closure attempts.
0 1-03	From 1 to 3 automatic closure attempts. We recommend setting a value equal to or lower than the value set for parameter R2. Automatic closure is only performed if the gate is completely open.
50 00	Setting photocell mode during gate opening (FT1)
00	DISABLED. Photocell is not active or not installed.
0 1	STOP. The gate stops and remains stationary until the next command is received.
02	IMMEDIATE REVERSE. The gate reverses immediately if the photocell is activated during gate opening.
03	TEMPORARY STOP. The gate stops as long as the photocell is obstructed. The gate resumed opening when the photocell is cleared.
04	DELAYED REVERSE. The gate stops if the photocell is obstructed. The gate closes when the photocell is cleared.

5102	Setting photocell mode during gate closing (FT1)
00	DISABLED. Photocell is not active or not installed.
01	STOP. The gate stops and remains stationary until the next command is received.
02	IMMEDIATE REVERSE. The gate reverses immediately if the photocell is activated during gate closure.
03	TEMPORARY STOP. The gate stops as long as the photocell is obstructed. The gate resumed closing when the photocell is cleared.
04	DELAYED REVERSE. The gate stops if the photocell is obstructed. The gate opens when the photocell is cleared.
5201	Photocell (FT1) mode with gate closed This parameter is not visible if <i>AB02</i> , <i>AB03</i> or <i>AB04</i> is set.
00	If the photocell is obstructed, the gate cannot open.
01	The gate opens when an open command is received, even if the photocell is obstructed.
02	The photocell sends the gate open command when obstructed (usable only if <i>L100</i>).
5300	Setting photocell mode during gate opening (FT2)
00	DISABLED. Photocell is not active or not installed.
01	STOP. The gate stops and remains stationary until the next command is received.
02	IMMEDIATE REVERSE. The gate reverses immediately if the photocell is activated during gate opening.
03	TEMPORARY STOP. The gate stops as long as the photocell is obstructed. The gate resumed opening when the photocell is cleared.
04	DELAYED REVERSE. The gate stops if the photocell is obstructed. The gate closes when the photocell is cleared.
5400	Setting photocell mode during gate closing (FT2)
00	DISABLED. Photocell is not active or not installed.
01	STOP. The gate stops and remains stationary until the next command is received.
02	IMMEDIATE REVERSE. The gate reverses immediately if the photocell is activated during gate closure.
03	TEMPORARY STOP. The gate stops as long as the photocell is obstructed. The gate resumed closing when the photocell is cleared.
04	DELAYED REVERSE. The gate stops if the photocell is obstructed. The gate opens when the photocell is cleared.
5501	Photocell (FT2) mode with gate closed This parameter is not visible if <i>AB02</i> , <i>AB03</i> or <i>AB04</i> is set.
00	If the photocell is obstructed, the gate cannot open.
01	The gate opens when an open command is received, even if the photocell is obstructed.
02	The photocell sends the gate open command when obstructed.
5600	Enable close command 6 s after activation of photocell (FT1-FT2) N.B.: This parameter is not visible if <i>AB03</i> or <i>AB04</i> is set. NOTE: in the case of photocells being blanked during opening, the 6 secs. count starts when the wings are completely open. If the automation enters stand-by in the fully open position, the function is not managed (the photocells are not powered)
00	Disabled.
01	Enabled. When the photocell barrier FT1 is crossed, a close command is sent 6 seconds later.
02	Enabled. When the photocell barrier FT2 is crossed, a close command is sent 6 seconds later.
6001	Limit switch type selection NOTE: only the 'micro-switch' selection allows contact monitoring even during the stand-by phase, as the magnetic limit switch in stand-by is not powered. Correct selection allows the control unit to optimally manage changes in status (e.g. if a manual movement occurs after the automation has been unlocked)
00	Micro-switch limit switches (pure contact)
01	Magnetic limit switches (hall effect sensors)

65 05	Setting motor stop distance
0 1-05	0 1= faster deceleration/shorter stop distance ... 05= slower deceleration/longer stop distance.
70 00	Maximum stroke length selection NOTE: For certified applications on standard gate dimensions of less than 20 metres, use the value 00
00	Maximum length 20 metres
01	Maximum length 25 metres
71 01	Selecting installation position of motor relative to gate (seen from interior side) N.B.: in the event of a reset to restore the default parameters, this parameter must be set again manually.
00	Motor installed on left.
01	Motor installed on right.
73 00	Configuring sensing edge COS1
00	Sensing edge NOT INSTALLED.
0 1	NC contact (normally closed). The gate reverses only when opening.
02	Contact with 8k2 resistor. The gate reverses only when opening.
03	NC contact (normally closed). The gate always reverses.
04	Contact with 8k2 resistor. The gate always reverses.
12	Management of two 8k2 sensitive edges connected in parallel (total resistance 4k1). The gate reverses only when opening.
14	Management of two 8k2 sensitive edges connected in parallel (total resistance 4k1). The gate always reverses.
74 00	Configuring sensing edge COS2
00	Sensing edge NOT INSTALLED.
0 1	NC contact (normally closed). The gate reverses only when closing.
02	Contact with 8k2 resistor. The gate reverses only when closing.
03	NC contact (normally closed). The gate always reverses.
04	Contact with 8k2 resistor. The gate always reverses.
12	Management of two 8k2 sensitive edges connected in parallel (total resistance 4k1). The gate reverses only when opening.
14	Management of two 8k2 sensitive edges connected in parallel (total resistance 4k1). The gate always reverses
76 00	Configuring radio channel 1 (PR1) N.B.: With ROGER TECHNOLOGY plug-in radio receiver board.
77 01	Configuring radio channel 2 (PR2) N.B.: With ROGER TECHNOLOGY plug-in radio receiver board.
00	STEP MODE.
0 1	PARTIAL OPENING
02	OPENING
03	CLOSING.
04	STOP.
05	Courtesy light. The output COR is managed from the remote control. The light remains lit as long as the remote control is active. The parameter 79 is ignored.
06	Courtesy light in step mode (PP). The output COR is managed from the remote control. The remote control turns the courtesy light on and off. The parameter 79 is ignored.
07	STEP MODE with confirmation for safety. ⁽¹⁾
08	PARTIAL OPENING with confirmation for safety. ⁽¹⁾
09	OPENING with confirmation for safety. ⁽¹⁾
10	CLOSURE with confirmation for safety. ⁽¹⁾

⁽¹⁾ To prevent gate manoeuvres caused by accidentally pressing a remote control button, confirmation is required to enable the command. Example: parameters 76 07 and 77 0 1 set:

- Pressing the CHA button on the remote control selects the step mode function, which must be confirmed within 2 seconds by pressing CHB on the remote control. Press CHB to activate partial opening.

78 00	Configuring flashing light frequency
00	The frequency is set electronically from the flashing light unit.
01	Slow flash.
02	Light flashes slowly when gate opens, rapidly when gate closes.
79 60	Selecting courtesy light mode
00	Disabled.
01	PULSE. The courtesy light illuminates briefly at the start of each manoeuvre.
02	ACTIVE. The light remains lit for the entire duration of the manoeuvre.
03-90	From 3 to 90 s. The light remains lit for the time period set after the manoeuvre is completed.
92-99	From 2 to 9 minutes. The light remains lit for the time period set after the manoeuvre is completed.
80 00	Clock contact configuration When the clock function is active, the gate opens and remains open. At the end of the programmed time set with the external device (clock), the gate closes.
00	When the clock function is active, the gate opens and remains open. Any command signal received is ignored.
01	When the clock function is active, the gate opens and remains open. Any command signal received is accepted. When the gate returns to the completely open position, the clock function is reactivated.
81 00	Enable safeguarded gate closure/opening Enabling this parameter ensures that the gate is not left open due to an incorrect and/or accidental command. This function is NOI enabled if: <ul style="list-style-type: none"> the gate receives a STOP command; the sensitive edge intervenes, detecting an obstacle in the same direction in which the function is enabled. If instead the sensitive edge detects an obstacle during the movement opposite to the one guaranteed, the function remains active. the number of closure attempts set by parameter R2 has been reached; the acquired position is lost (perform position recovery, see chapter 20).
00	Disabled. The parameter B2 is not displayed.
01	Enabled. After a period of time set with parameter B2 , the control unit signals a 5 second warning with the flashing light, regardless of the parameter R5 , and then closes the gate.
02	Enabled. If the gate is closed as a result of a step mode command, after a period of time set with parameter B2 , the control unit signals a 5 second warning with the flashing light (regardless of the parameter R5), and then the gate closes. If the gate is stopped by the obstacle detection system during a closure manoeuvre, the gate closes after a period of time set with parameter B2 . If the gate is stopped by the obstacle detection system during an opening manoeuvre, the gate closes after a period of time set with parameter B2 .
82 03	Setting safeguarded closure/opening activation time N.B.: this parameter is not visible if the value of parameter B 1 = 00.
02-90	Wait time settable from 2 to 90 s.
92-99	Wait time settable from 2 to 9 min.
85 03	Selection of the battery operation management Setting a value different than 00 a battery voltage level check is activated. The desired operation type can be selected via parameter B6 and an error alert can be activated through the COR output via parameter 2D .
00	The control unit always accepts commands until the battery is completely exhausted. When the battery voltage drops to the minimum allowed, the message bE L D appears on the display (20V $\overline{\text{---}}$ with B71/BCHP battery charger; 23.7V $\overline{\text{---}}$ with B71/PBX external battery charger). The control unit no longer accepts commands.
01	The command becomes active when the battery voltage drops to the minimum threshold (22V $\overline{\text{---}}$ for battery 2x12V $\overline{\text{---}}$, 36.4V $\overline{\text{---}}$ for battery 3x12V $\overline{\text{---}}$)
02	The command becomes active when the battery voltage drops to the medium threshold (23V $\overline{\text{---}}$ for battery 2x12V $\overline{\text{---}}$, 36.8V $\overline{\text{---}}$ for battery 3x12V $\overline{\text{---}}$)
03	The command becomes active when the battery voltage drops to the maximum threshold (24V $\overline{\text{---}}$ for battery 2x12V $\overline{\text{---}}$, 37.2V $\overline{\text{---}}$ for battery 3x12V $\overline{\text{---}}$)

86 00	Selecting the battery operation limitations N.B.: the parameter is visible only if par. 85 is different than 00
00	There is no limitation for the commands when the battery voltage drops under the selected threshold. An error alert may be activated via the COR output (if parameters 85 and 20 are adequately set).
01	When the battery voltage drops under the threshold selected with par. 85, the control unit accepts only opening commands and does not perform closing.
02	When the battery voltage drops under the threshold selected with par. 85, after a 5 s pre-flashing, the control unit automatically opens the gate and accepts only a closing command.
03	It accepts only closing commands even if the ORO input is active and if the parameter is 80 0 1.
04	When the battery voltage drops under the threshold selected with par. 85, after a 5 s pre-flashing, the control unit automatically closes the gate and accepts only one opening command.
87 00	Selection of the battery type and consumption reduction NOTE: An INCORRECT setting of this parameter, when there is no mains voltage, blocks the functions and the display shows the message bEtL0 (if set to 0 1 or 02 and the battery is 2x12V---) or an error alert b7bd.
00	Battery 24V--- (2x12V---) with B71/BCHP. Acceleration/deceleration/speed reduction enabled, to increase the battery life.
01	Battery 36V--- (3x12V---) with external battery charger B71/PBX. Acceleration/deceleration/speed reduction enabled, to increase the battery life.
02	Battery 36V--- (3x12V---) with external battery charger B71/PBX. No performance reduction, maximum battery consumption.
88 00	Cyclical activation (test mode) The automation system is activated in opening mode at intervals defined by the parameter; automatic closing must be selected (par.82 and par.2 1).
00	Disabled.
0 1-90	Opening command activated every 1" ... 90" NOTE: While the cyclical activation command concerns the opening movement, it is controlled so as to allow a complete opening-pause-closing cycle before starting again; consequently, if the time set in par.88 is less than the time to complete the cycle, the control unit waits for the complete closure, and from that moment, it gives another opening command, after a time equivalent to the parameter value E.g. opening time = closing time = 15"; pause time = 2" By setting par.88=33 it starts a complete cycle every 33" By setting par.88= 15 it completes a cycle, remains completely closed for 15" and then starts over, so it starts a complete cycle every 32" + 15" = 47"
9 1-99	Opening command activated every 1min ... 9 min.
89 00	Enabling parameter management of the SLAVE control unit using B74/BCONNECT inserted on the MASTER control unit By inserting a B74/BCONNECT on the MASTER control unit, it is possible to use the parameter consultation, modification and backup menus also for the SLAVE control unit, setting the value 0 1 on the MASTER control unit. ATTENTION! Once the operations are complete, remember to set the value back to 00.
00	Disabled.
0 1	on the MASTER control unit allows: - displaying the parameters and editing the individual SLAVE parameters - saving the backup of the parameters taken from the SLAVE control unit to B-CONNECT
LD 00	Enabling serial communication
00	Disabled
0 1	Enabling module B74/BCONNECT
02	Enabling debug board (internal use)

L104	<p>Configuration of 'low power stand-by' mode</p> <p>NOTE: 'low power stand-by' is activated after inactivity that lasts for the preset time, i.e. with the automation stopped and no activation of commands or keys on the display.</p> <p>With the automation fully open and paused for automatic reclosing, stand-by is not activated, as it is in any case an active phase of automatic operation (regulated by par. R2 and Z1).</p> <p>Similarly, the time countdown for guaranteed closing/opening (par. B1 and B2) is considered an active phase, so stand-by is not activated.</p>
00	"low power" mode disabled
01	Stand-by activation after 5 minutes of inactivity
02	Stand-by activation after 10 minutes of inactivity
03	Stand-by activation after 15 minutes of inactivity
04	Stand-by activation after 20 minutes of inactivity

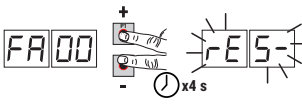
FR00	<p>Restoring factory default values</p> <p>NOTE This procedure is only possible if NO data protection password is set.</p>
	<div style="display: flex; align-items: flex-start;"> <div style="margin-right: 20px;">  </div> <div> <p>Warning! Restoring default settings cancels all settings made previously except for parameter RD, R1, E0, T1, B5, B7, B9, L0, L1: after restore, check that all parameters are suitable for the installation.</p> <ul style="list-style-type: none"> • Press the PLUS + and MINUS - button. • The display flashes after 4 s rE5- </div> </div> <p>• The default factory settings have now been restored.</p> <p>Note: it is possible to reset the parameters in a second way: when the control unit is switched on, before the firmware version appears on the display, press and hold down the ▲ (UP ARROW) and ▼ (DOWN ARROW) buttons for 4s.</p>

<p>Identification number</p> <p>The identification number consists of the values of the parameters from n0 to n5.</p> <p>N.B.: The values shown in the table are indicative only.</p>		
n001	HW version	
n123	Year of manufacture	
n245	Week of manufacture	
n367		
n489		Example: 01 23 45 67 89 01 23
n501		
n623	FW sequential version	
n713	MASTER/SLAVE RS485 communication version	

<p>View manoeuvre counter</p> <p>The number consists of the values of the parameters from o0 to o1 multiplied by 100.</p> <p>N.B.: The values shown in the table are indicative only.</p>		
o001		
o023		Manoeuvres performed.
o145		Example: 01 23 45 x100 = 1.234.500 manoeuvres.

<p>View manoeuvre hour counter</p> <p>The number consists of the values of the parameters from h0 to h1.</p> <p>N.B.: The values shown in the table are indicative only.</p>	
h001	
h123	
	Example: 01 23 = 123 hours.

View control unit days on counter

The number consists of the values of the parameters from $d0$ to $d1$.

N.B.: The values shown in the table are indicative only.

$d0$ 01

Days with unit switched on.

$d1$ 23

Example: $d1$ 23 = 123 days.

Password

Setting a password prevents unauthorised persons from accessing the settings.

With password protection active ($CP=01$), parameters may be viewed, but the values CANNOT be modified.

Only a single password is used to control access to the gate automation system.

WARNING: Contact the Technical Support Service if you lose your password.

$P1$ 00

$P2$ 00

$P3$ 00

$P4$ 00

Password activation procedure:

- Enter the desired values for parameters $P1$, $P2$, $P3$ and $P4$.
- Use the UP ▲ and/or DOWN ▼ buttons to view the parameter CP .
- Press and hold the + and - buttons for 4 seconds.
- The display flashes to confirm that the password has been saved.
- Switch the control unit off and on again. Check that password protection is activated ($CP=01$).

Temporary unlock procedure:

- Enter the password.
- Check that $CP=00$.

Password cancellation procedure:

- Enter the password ($CP=00$).
- Save the values $P1 = 00$, $P2 = 00$, $P3 = 00$, $P4 = 00$
- Use the UP ▲ and/or DOWN ▼ buttons to view the parameter CP .
- Press and hold the + and - buttons for 4 seconds.
- The display flashes to confirm that the password has been cancelled (the values $P1$ 00, $P2$ 00, $P3$ 00 and $P4$ 00 indicate that no password is set).
- Switch the control unit off and on again.

CP 00

Changing password

00

Protection deactivated.

01

Protection activated.

13 Special parameters for HIGH SPEED series



The BG30/HS series (High Speed) is a family of digital brushless high speed sliding motor units for sliding gates weighing up to 800 kg, 1000 kg, 1500 kg or 1800 kg and dedicated exclusively to residential applications.

High Speed technology makes it possible for the automation system to operate 100% faster than a conventional system, and allows independent management of speed, acceleration, deceleration and the safety devices used in the system.

Note: As the mechanics of the gate is unknown, to guarantee the maximum safety of the installation, we recommended to use sensitive edges.

The additional parameters for enabling High Speed technology are indicated as follows.

A 103	Selecting automation system model
A 105	This parameter is factory configured by ROGER TECHNOLOGY.
A 106	WARNING! The parameter is already configured by default to enable use of the of motor in high speed mode. If this parameter is modified, all the specific motor functions relative to high speed mode will no longer be available. The automation system will no longer function effectively and it will not be possible to diagnose faults.
A 107	N.B.: in the event of a reset to restore the default parameters, this parameter must be set again manually.
01	BG30/1600 - IRREVERSIBLE motor for gate leaves up to 1600 kg.
02	BG30/2200 - IRREVERSIBLE motor for gate leaves up to 2200 kg.
03	BG30/1000/HS - High Speed IRREVERSIBLE motor for gate leaves up to 1000 kg.
04	BG30/1400/R - REVERSIBLE motor for gate leaves up to 1400 kg.
05	BG30/1800/HS - High Speed IRREVERSIBLE motor for gate leaves up to 1800 kg.
06	BG30/1500/HS - High Speed IRREVERSIBLE motor for gate leaves up to 1500 kg.
07	BG30/804/HS - High Speed IRREVERSIBLE motor for gate leaves up to 800 kg.
1104	Setting deceleration during opening
1204	Setting deceleration during closing
01-05	01= the gate decelerates near the limit switch ... 05= the gate decelerates long before the limit switch.
3304	Setting start acceleration during opening
3404	Setting start acceleration during closing
01-05	01= the gate accelerates rapidly at start of manoeuvre ... 05= the gate accelerates slowly and progressively at start of manoeuvre.
4008	Setting opening speed N.B.: the speed setting range for the specific motor installed is automatically subdivided into 10 equal segments.
4108	Setting closure speed N.B.: the speed setting range for the specific motor installed is automatically subdivided into 10 equal segments.
01-10	01= 6 m/min ... 10= maximum speed.



N.B.: to set the constant speed deceleration space, see parameters 13 and 14 on Chapter 12.

14 Special parameters for BG30/1400/R series



The BG30/R series (REVERSIBLE) is a family of digital brushless motor units for sliding gates weighing up to 1400 kg and dedicated exclusively to residential and industrial applications.

REVERSIBLE technology makes it possible to open and close the gate without releasing the motor even in the event of power failure. When the gate is moved manually, in the absence of supply voltage, the rotation of the motor provides power to the control unit the display lights up and the message 'SELF' appears. **WARNING!** handle the gate by hand with moderation.

The control unit allows independent management of speed, acceleration, deceleration and the safety devices used in the system.

During normal operation (including operation under battery power), the control unit applies a sufficient braking force to impede manual movement of the gate.

As a result, prolonged operation may drain the battery when operating under battery power.

If the braking force applied is not sufficient to impede manual movement of the gate and a gate movement of more than 3 cm is detected, the control unit initiates a position recovery procedure (see chapter 20).

NOTE: Even though it is a REVERSIBLE unit, the motor is equipped with a lock release system.

The additional parameters for enabling REVERSIBLE technology are indicated as follows.

A 104	Selecting automation system model This parameter is factory configured by ROGER TECHNOLOGY. WARNING! The parameter is already configured by default to enable use of the of motor REVERSIBLE mode. If this parameter is modified, all the specific motor functions relative to REVERSIBLE mode will no longer be available. The automation system will no longer function effectively and it will not be possible to diagnose faults. N.B.: in the event of a reset to restore the default parameters, this parameter must be set again manually.
01	BG30/1600 - IRREVERSIBLE motor for gate leaves up to 1600 kg.
02	BG30/2200 - IRREVERSIBLE motor for gate leaves up to 2200 kg.
03	BG30/1000/HS - High Speed IRREVERSIBLE motor for gate leaves up to 1000 kg.
04	BG30/1400/R - REVERSIBLE motor for gate leaves up to 1400 kg.
05	BG30/1800/HS - High Speed IRREVERSIBLE motor for gate leaves up to 1800 kg.
06	BG30/1500/HS - High Speed IRREVERSIBLE motor for gate leaves up to 1500 kg.
1104	Setting deceleration during opening
1204	Setting deceleration during closing
01-05	01= the gate decelerates near the limit switch ... 05= the gate decelerates long before the limit switch.
3304	Setting start acceleration during opening
3404	Setting start acceleration during closing
01-05	01= the gate accelerates rapidly at start of manoeuvre ... 05= the gate accelerates slowly and progressively at start of manoeuvre.
4008	Setting opening speed N.B.: the speed setting range for the specific motor installed is automatically subdivided into 10 equal segments.
4108	Setting closure speed N.B.: the speed setting range for the specific motor installed is automatically subdivided into 10 equal segments.
01-10	01= 6 m/min ... 10= maximum speed.



N.B.: to set the constant speed deceleration space, see parameters 13 and 14 on Chapter 12.

15 Safety input and command status (TEST mode)

With no currently active commands, press the TEST button and check the following:

DISPLAY	POSSIBLE CAUSE	ACTION BY SOFTWARE	PHYSICAL CORRECTIVE ACTION
885b (Sb)	The release handle is open.	-	Close the release handle and turn the key to the close position. Check that the release contact is connected correctly.
88 17	The safety STOP contact is open.	-	Install a STOP button (NC) or jumper the ST contact with the COM contact.
88 15	Sensing edge COS1 not connected or incorrectly connected.	Set the parameter 7300 if not used or to disable.	Jumper contact COS1 with contact COM, if not used or to disable.
88 14	Sensing edge COS2 not connected or incorrectly connected.	Set the parameter 7400 if not used or to disable.	Jumper contact COS2 with contact COM, if not used or to disable.
88 13	Photocell FT1 not connected or incorrectly connected.	Set the parameter 5000 e 5 100 if not used or to disable.	Jumper contact FT1 with contact COM, if not used or to disable. Check connection referring to relative connection diagram.
88 12	Photocell FT2 not connected or incorrectly connected.	Set the parameter 5300 e 5400 if not used or to disable.	Jumper contact FT2 with contact COM, if not used or to disable. Check connection referring to relative connection diagram.
88FE	Both limit switches in open contact state or not connected.	-	Check connection of limit switches.
88FA	Gate is at gate closed limit switch.	If the limit switch state indicated is incorrect, check the setting of parameter 7 I.	-
	Gate open limit switch absent or not connected.	-	Check connection of limit switches.
88FC	Gate is at gate closed limit switch.	If the limit switch state indicated is incorrect, check the setting of parameter 7 I.	-
	Gate closed limit switch absent or not connected.	-	Check connection of limit switches.
88nC	No RS485 communication between MASTER and SLAVE control units.	See instructions for MASTER/SLAVE management.	See instructions for MASTER/SLAVE management.
PP00	If occurs with no voluntary command, the contact (N.O.) may be faulty or one of the buttons may be incorrectly connected.	-	Check PP - COM contacts and connections to buttons.
CH00		-	Check CH - COM contacts and connections to buttons.
AP00		-	Check AP - COM contacts and connections to buttons.
PE00		-	Check PED - COM contacts and connections to buttons.
Or00	If occurs with no voluntary command, the contact (N.O.) may be faulty or the timer may be incorrectly connected.	-	Check ORO - COM contacts. Contact must not be jumpered if not used.

N.B: press TEST to exit TEST mode.

We recommend troubleshooting safety device and input status errors with "corrective action by software" only.

NE

16 Alarms and faults

PROBLEM	ALARM	POSSIBLE CAUSE	ACTION
The gate does not open or close.	LED POWER off	No power.	Check power cable.
	LED POWER off	Fuses blown.	Replace fuses. Always disconnect from mains power before removing fuses. If the F3 fuse breakage occurs again, and the control unit controls a HighSpeed motor, disconnect the B72/CL device (or the B71/BCHP version HW 02 battery charger) from the Battery Charger connector and see if it does not happen again. If so, proceed with the replacement of the device, which is damaged.
	<i>OFSt</i>	Input mains power voltage fault. Control initialisation failed.	Disconnect from mains power, wait 10 seconds then reconnect to the mains and switch on. If the problem persists, contact your local authorized dealer for verification and possible assistance. Pressing the TEST button it is possible to hide the alarm temporarily and consult the control unit's parameters.
	<i>FUSE</i>	Fuse F1 blown or damaged. This message is not visible if controller is in battery power mode.	Replace fuse. Always disconnect from mains power before removing and refitting fuses.
	<i>PrOt</i>	Overcurrent detected in inverter.	Press the TEST button twice or perform 3 command requests in succession.
	<i>SECO</i>	Incorrect connection to transformer SEC1-SEC2.	Swap connections between SEC1 and SEC2.
	<i>dAtA</i>	Travel data acquisition error.	Check that open and closed limit switches are positioned correctly. Press TEST and check if any safety devices are in alarm state. Repeat acquisition procedure.
		Calibration procedure failed.	Allow the indicated calibration times to elapse during self-acquisition. Check that <i>PHAS</i> is shown flashing on the display before closing the release lock cover. Repeat acquisition procedure.
	<i>Not</i>	Motor not connected.	Check the motor cable.
	<i>FE</i>	Both limit switches activated.	Check connections of limit switches or check for foreign objects in limit switch blocks.
	example: <i>1SE</i> <i>21EE</i>	Configuration parameter error.	Set configuration value correctly and save.
	<i>EnE 1</i>	Encoder not connected.	Check connection to encoder. Replacing the encoder is recommended if the problem persists.
	<i>EnE3</i>	Severe encoder malfunction.	Press TEST button. If the error code is displayed again, switch off the controller unit, wait 5 seconds and switch on again. Replace the encoder if the problem persists.
	<i>EnE5</i> (EnE5)	Encoder malfunction.	Press TEST button. Replace the encoder if the problem persists.
		Insufficient power supply	If the unit contains dirt, moisture, insects or other foreign matter, disconnect from mains power and clean the board and the encoder. Replace the encoder if the problem persists.
		Batteries functioning	The batteries are almost flat.
<i>EnEB</i>	Encoder calculation error.	Repeat acquisition procedure.	
<i>tENP</i>	Inverter thermal overload circuit breaker tripped.	Function is restored automatically within 2 min.	
<i>btLO</i> (btLO)	Flat batteries.	Wait for mains power to be restored.	
<i>COI 1</i>	No RS485 serial communication between MASTER control unit and SLAVE control unit.	Check connection to terminals COM-LNA-LNB.	
		Check settings of parameter <i>AD</i> . Check that battery kit is installed on both MASTER and SLAVE control unit.	

PROBLEM	ALARM	POSSIBLE CAUSE	ACTION
The gate does not open or close.	<i>COF2</i>	Serial communication interference: two MASTER controllers detected.	Check settings of parameter <i>AD</i> .
	<i>COF3</i>	Parameter configuration transfer error between MASTER and SLAVE.	Check connection to terminals COM-LNA-LNB.
	<i>COF4</i>	Incompatibility between firmware versions of controller units.	Check parameter <i>n7</i> . The connected control units must have the same RS485 communication version. Contact the technical assistance.
	<i>Stop</i> flashing	Release device open.	Close the release handle and turn the key to the close position. Check that the release contact is connected correctly.
Acquisition procedure does not complete correctly.	<i>noPH</i>	Motor calibration failed.	Repeat acquisition procedure. If the problem persists, check the cable connecting the encoder to the motor. Check if release handle is open. Check that the motor turns without impediment. Contact technical support in case of any problems. Check that the mains voltage is correct and that the mains cable cross-section is adequate.
		Problems with the encoder circuit or on the connecting cable.	Check the good condition of the connection cable. Disconnect and then reconnect from main power. Give a command (opening/step-by-step, ...). If <i>noPH</i> does NOT appear, repeat the learning procedure. If <i>noPH</i> appears again contact the technical assistance.
		TEST button pressed accidentally.	Repeat acquisition procedure.
		Safety devices in alarm state.	Press the TEST button and check the safety device/s in alarm state and the connections of the safety devices.
	<i>APPE</i>	Excessive voltage drop.	Repeat acquisition procedure. Check mains voltage.
		Incorrect setting of parameters <i>30</i> and <i>31</i> .	Adjust parameters <i>30</i> and <i>31</i> correctly for the weight and speed of the gate leaf.
	<i>APPL</i>	Travel length error.	Move gate into completely closed position (FC limit switch signal must be active) and repeat the procedure.
			Check cable of limit switches. Replace the cable if the problem persists.
			Reset default controller unit parameters and repeat the procedure. Stroke length less than the minimum allowed: increase the length.
	<i>APP1</i>	Maximum permitted travel length exceeded	Reduce the ride. Contact technical assistance (travel exceeding the maximum allowed by the technical characteristics).
Remote control has limited range and does not work while automated gate is moving.	-	The radio transmission is impeded by metal structures and reinforced concrete walls.	Install the antenna outside.
	-	Flat batteries.	Replace the transmitter batteries.
The flashing light is not working.	-	Bulb / LED blown or flashing light wires disconnected.	Check LED circuit and/or connector wires.
Gate open indicator lamp does not work.	-	Bulb blown or wires disconnected.	Check the bulb and/or wires.
Gate does not perform desired manoeuvre.	-	Incorrect setting of parameter <i>71</i> .	Select the correct installation position with parameter <i>71</i> .
	<i>b7od</i>	Incorrect selection of the battery type.	Change the value of the parameter <i>B7</i> .
	<i>HbU5</i>	Mains voltage too high	Check mains voltage, check BUS voltage (INFO size: <i>bU5</i> , see par. 18), contact the service department. By pressing TEST the signal disappears for 7 seconds from the last activation of the keys around the display.
"Low power" mode does not activate	<i>noLP</i>	B70/MODLP damaged / relay contact stuck.	Control exercised by H93/RX2LP/I faulty. Wiring between H93/RX2LP/I and B70/MODLP defective.
Transformer incorrectly switched off by B70/MODLP	<i>noEr</i>	B70/MODLP damaged / relay contact stuck.	Control exercised by H93/RX2LP/I faulty. Wiring between H93/RX2LP/I and B70/MODLP defective.

N.B.: Press the TEST button to temporarily cancel the alarm.

The next time a command is received, the alarm reappears on the display if the problem has not been resolved.

17 Procedural verifications - INFO Mode

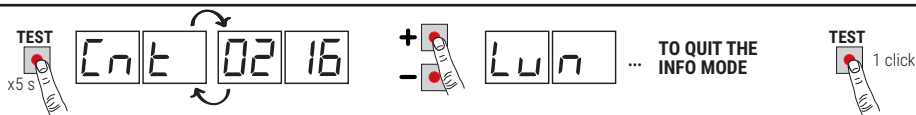

INFO mode may be used to view certain parameters measured by the **B70/1DCHP** controller. Press and hold the TEST button for 5 seconds from the "View command signals and safety devices" mode with the motor stationary.

The control unit displays the following parameters and the corresponding measured values in sequence:

Parameter	Function
<i>P3.00</i>	View for 3 s the firmware version of the control unit.
<i>Cnt</i>	Displays the position of MOTOR, expressed in revolutions and relative to total length, at the time of the test. (example: <i>0113</i> = motor installed on the left <i>7100</i> ; <i>0113</i> = motor installed on the right <i>7101</i>).
<i>Lun</i>	View total length of programmed travel of MOTOR, in motor revolutions.
<i>rPn</i>	View motor speed of MOTOR, in revolutions per minute (rPM).
<i>RnP</i>	View current absorption of motor, in Amperes (e.g.: 001.1 = 1,1 A ... 016.5 = 16,5 A). If the MOTOR is stationary, the current absorption value is 0. Activate a command function to test current absorption.
<i>bUS</i>	System OK indicator. To check for overloading (e.g.: too many utilities connected to 24 V output) or if the mains voltage is too low, compare the parameters read with values indicated as follows with the motor stationary: mains voltage = 230V~ (nominal), <i>bUS</i> = <i>37.5</i> mains voltage = 207V~ (-10%), <i>bUS</i> = <i>33.5</i> mains voltage = 253V~ (+10%), <i>bUS</i> = <i>41.5</i>
<i>CnP</i>	Display current, expressed in Amperes, used to compensate for strain detected by MOTOR due, for example, to low external temperatures (e.g.: 0 = 0 A ... 4 = +12 A). At the beginning of a manoeuvre from the completely open or completely closed position, if the control unit detects a strain higher than the value stored in its memory during the travel acquisition cycle, the controller automatically increases the current delivered to MOTOR.
<i>RSC</i>	Display current threshold, expressed in Amperes, at which the obstacle detection function (crush prevention) of MOTOR is triggered. This value is calculated automatically by the controller in relation to the settings of parameters <i>30</i> and <i>31</i> . For the motor to function correctly, <i>RnP</i> must always be lower than the value <i>RSC</i> .
<i>tIn</i>	Indicates time taken by MOTOR to detect an obstacle, as set with parameter <i>31</i> , in seconds. E.g. <i>1.000</i> = 1 s / <i>0</i> . <i>120</i> = 0.12 s (120 ms). Ensure that the manoeuvre time is more than 0.3 s.
<i>UP</i>	If the control unit is capable of identifying the position of the gate when the test is conducted, the following is shown on the display: <i>UP--</i> position known, normal operation. <i>UP L</i> position unknown, position recovery in progress.
<i>DC</i>	Indicates the state of the automation system (open/closed). <i>DC DP</i> automation system opening (motor active). <i>DC CL</i> automation system closing (motor active). <i>DC -D</i> automation system completely open (motor not actives). <i>DC -C</i> automation system completely closed (motor not actives).
<i>UF</i>	<i>UF U</i> mains voltage too low or overload. <i>UF H</i> motors overcurrent.
<i>nPEE</i>	Displays the number of thermal protection interventions of the inverter. If it displays a number different from 0000, check that there are no excessive stress points and if the leaf, coming onto mechanical stops, does not activate the limit switch. Check the settings of parameters <i>30</i> and <i>31</i> .
<i>Hibv</i>	Displays information about the electronic voltage limiter (ROGER TECHNOLOGY's TECHNICAL ASSISTANCE ONLY).
<i>nSAR</i>	Displays a number which indicates the status of the control unit (INTERNAL USE - ROGER TECHNICAL ASSISTANCE)
<i>rSAR</i>	Displays a number which indicates the status of the SLAVE control unit (INTERNAL USE - ROGER TECHNICAL ASSISTANCE) and visible only on the MASTER control unit; on the SLAVE control unit, ---- is always displayed.
<i>ErrL</i>	Number of RS485 communication errors (it gets reset by pressing "arrow down" ▼): this could highlight problems at board circuit level.
<i>ErrC</i>	Number of communication protocol errors (it gets reset by pressing "arrow down" ▼). It can highlight: • problems at connection cable level LNA/LNB/COM (reduced section, excessive length, closeness to cables with switching loads) • difficulties in communicating with the SLAVE control unit.

- Use the + / - buttons to scroll through the parameters. When the last parameter in the sequence is reached, press the - button to return through the previous parameters.
- In INFO mode, the automation system may be activated to test operation in real time.
- Press and hold the TEST button for a few seconds to exit INFO mode.

17.1 B74/BCONNECT mode

Use of the B74/BCONNECT must be enabled by setting par. L0=0 1; by default this parameter is 00 (disabled). The use of the device requires disabling the low-power management (L 1 00), as described in section 9.4.

By inserting **B74/BCONNECT** in the **WiFi** connector, all the functions are managed through internet browser and devices such as smartphones, tablets, PCs, exploiting WiFi communication, tablet, PC, all the functionalities of the central unit are managed, using the WiFi communication.



For further information consult the installation manual of the connection module B74/BCONNECT connection module.

Remote assistance" mode

Allows access and therefore the management of all the data of the control unit only in cloud mode and therefore with remote management.

When remote assistance is enabled, the message **ASCC** (assistance connect controlled) appears on the display.

By pressing the **TEST** button this message disappears for 10 seconds, and it is possible to access the parameters and other functions of the display.

After 30 minutes the display goes into stand-by, if the display is awakened by pressing a key the flashing ASCC reappears.

"Emergency operation" mode

This mode is used to exclude motor and safety alarms (e.g. photocells and sensitive edges), allowing the automation to open and close at low speed and with the operator present, with movement of the leaves only in the presence of a persistent command (when the command is released, the leaves stop).

Emergency operation is indicated by activation of the flashing light at a higher frequency.

Two types of "emergency" mode are possible: residential or condominium.

1) **residential** (flashing **L-ES** display indication): the PP command (from the terminal board or radio control) is initially managed as an opening command; only when complete opening has been reached will activation of the command send it to closing. Only when complete closure has been achieved will the command be able to open again.

2) **condominium** (flashing **L-EM** display indication): the PP command is initially managed as an opening command, but once it has been fully opened the leaves no longer close.

In this mode the display stand-by is not activated, always indicating the mode in progress.

By pressing the **TEST** button this message disappears for 10 seconds, and it is possible to access the parameters and other functions of the display.

ASCC	"Remote assistance" mode enabled
L-ES	"Residential emergency operation" mode enabled
L-EM	"Condominium emergency operation" mode enabled

18 Voltage limiter (B72/CL)

The control units which control High Speed and Reversible motors in certain operating situations may, in the event of abrupt braking (STOP command or intervention of the sensitive edge, or any reversal command if par. B5 set to 0 1) experience an increase in the motor supply voltage, which rises due to the dynamo effect. The B72/CL, plugged into the BATTERY CHARGER connector, controls and limits these peaks by activating a current draw.

Activation, which occurs by a few quick pulses within 1 second, is indicated by the 'CLAMP' LED on the B72/CL flashing.

If the "CLAMP" LED remains permanently lit, it means that B72/CL is damaged, a PTC thermal protection intervenes by disconnecting it from the motor supply voltage and simultaneously forcing an overload on the 24V supply by blowing the F3 fuse, thus switching off the control unit.

This is done to signal the loss of the limiting function, which in the event of continued operation could eventually cause damage to the inverter.

In such a case, proceed to replace B72/CL.

ATTENTION! If the battery charger is to be used, it must be in **hardware version 02 (HW 02)** because only this version integrates the voltage limiter function. Remove the B72/CL from the connector and replace it with the charger.

ATTENTION! in order to guarantee correct operation of the automation in all working conditions, THE B72/CL DEVICE MUST NOT BE REMOVED, unless you wish to use the B71/BCHP HW02 battery charger (as it uses the same connector).

IT IS MANDATORY TO PURCHASE AND INSTALL the B72/CL voltage limiter for those who purchased an engine in the BG30 series versions (BG30/804/HS, BG30/1004/HS, BG30/1504/HS, BG30/1804/HS, BG30/1404/R) before NOVEMBER 2023.

19 Mechanical release

In the event of a fault or mains power loss, the gate may be released and opened manually.



For further information, refer to the locking/release operation in the manual of the automation system.

If the gate releases with the controller unit powered, the message **5EOP** flashes on the display.

When the release system is restored to the normal operating position, if the gate is not completely open or completely closed the next time a command is received, the control initiates a position recovery procedure (see chapter 20). Activating one of the two limit switches immediately reacquires the position.

20 Position recovery mode

After a mains power outage or after mechanically releasing the gate, if the gate is not completely open or completely closed the next time a command is received, the control initiates a position recovery procedure:

- The gate starts a low speed manoeuvre.
- The flashing light flashes with a different duty cycle than normal (3 s on, 1.5 s off).
- The control unit recovers the installation data during this procedure. **Warning!** During this procedure, do not use any controls until one of the two limit switches is reached.
- Activating one of the two limit switches immediately reacquires the position.

When the control unit receives a command signal after a power failure or after the motor has been mechanically released, if the gate is completely open or completely closed, it initiates a position recovery procedure to precisely determine the exact position of the gate.

The gate releases the limit switch, briefly stops and resumes the manoeuvre at the speed set at parameters **40** and/or **41**. Arrival on the opposite limit switch takes place at reduced speed, which is automatically set (regardless of the settings of the parameters **13**, **14** and **42**), recovering the position control with maximum accuracy.

The gate clears the limit switch, stops briefly and then resumes the manoeuvre until it reaches the opposite limit switch at reduced speed (regardless of the settings of parameters **13**, **14** and **42**), to restore position control with absolute precision. For **BG30/1400/R** motors only. If the control unit detects that the gate has been moved manually by more than 3 cm from the initial position, it initiates a position recovery procedure.

21 Initial testing

The testing must be performed by qualified technical personnel.

The installer is required to measure impact forces and select on the control unit the appropriate speed and torque values to ensure that the motorised door or gate remains within the limits defined by the standards EN 12453 and EN 12445.

Make sure that the provisions in "GENERIC WARNINGS" are observed.

- Turn on the power supply.
- Check that all connected controls are working correctly.
- Check that the release handle works correctly. The message **5EOP** must flash on the display.
- Check travel and deceleration.
- Check if the impact forces are compliant with the EN 12453 and EN 12445 standards.
- Check that the safety devices are activated correctly.
- If the battery kit is installed, disconnect from mains and check that the batteries are working.
- Disconnect from mains power and disconnect the batteries (if used), then reconnect. Starting with the gate stopped in an intermediate position, check that the position recovery procedure is completed correctly for both the open and closed positions.
- Check that the limit switches are set correctly and function correctly. If necessary, adjust the motor installation position.
- Check that there is a gap of at least 2-3 cm between the gate and the mechanical stop at the end of the manoeuvre.

Declaration CE of Conformity

The undersigned Dino Florian, legal representative of Roger Technology - Via Botticelli 8, 31021 Mogliano V.to (TV) DECLARES that the **B70/1DCHP** digital control unit is compliant with the provisions established by Community directives:

- 2014/35/UE LVD Directive
- 2014/30/UE EMC Directive
- 2014/53/UE RED Directive
- 2011/65/UE RoHS Directive

and that all the standards and/or technical requirements indicated as follows have been applied:

EN 61000-6-3
EN IEC 61000-6-2
EN 60335-1

Place: Mogliano V.to

Date: 02/05/2016

Signature

ACHTUNG! Dieses Handbuch ist nur für qualifiziertes Personal bestimmt; lesen Sie sorgfältig die allgemeinen Warnhinweise, die diesem Handbuch beiliegen.

ACHTUNG! Der Funkempfänger H93/RX2LP/I ist voll kompatibel mit den Funkempfängern H93/RX20/I - H93/RX22A/I- H93/RX2RC/I, die entweder einen festen Code oder einen "Rolling Code" (konfigurierbar) dekodieren können.

Weitere Informationen über den LOW POWER Modus finden Sie im B70/MODLP Handbuch und in Kapitel 9.4 Stand By Modus.

Weitere Informationen zum MASTER/SLAVE-Modus finden Sie im MASTER/SLAVE-Handbuch, das Sie auf der Website www.rogertechnology.it im Bereich DOKUMENTATION --> STEUERZENTRALEN herunterladen können.

1 Symbole

Im Folgenden zeigen wir die Symbole und ihre Bedeutung, die im Handbuch oder auf den Produktetiketten verwendet werden.

	Allgemeine Gefahr. Wichtige Sicherheitsinformationen. Weist auf Vorgänge oder Situationen hin, bei denen das Personal sehr genau aufpassen muss.
	Gefahr gefährlicher Spannung. Weist auf Vorgänge oder Situationen hin, bei denen das Personal sehr genau auf gefährliche Spannungen achten muss.
	Nützliche Informationen Weist auf nützliche Informationen für die Installation hin.
	Konsultieren der Installations- und Bedienungsanweisungen. Weist auf die Verpflichtung hin, das Handbuch oder das Originaldokument zu konsultieren, das für die zukünftige Verwendung verfügbar sein muss und in keiner Weise beschädigt werden darf.
	Verbindungsstelle der Erdung.
	Gibt den zulässigen Temperaturbereich an.
	Wechselstrom (AC)
	Gleichstrom (DC)
	Symbol für die Entsorgung des Produkts gemäß der WEEE-Richtlinie.

2 Produktbeschreibung

Die digitale Steuereinheit **B70/1DCHP** mit 36 V verwendet zur Steuerung des bürstenlosen Motors BG30 ROGER für einflügelige Schiebetorantriebe die Motorleistungskontrolle im Modus mit Sensor und unter Verwendung eines hochauflösenden Encoders.

 **Es muss auf die Einstellung des Parameters A1 geachtet werden. Eine falsche Einstellung kann Funktionsstörungen des Antriebs verursachen.**

Wenn das Gerät B70/MODLP über eine 3-Draht-Verkabelung mit dem Empfänger H93/RX2LP/I verbunden ist, überwacht die Steuereinheit den Betriebszustand, indem sie nach einer voreingestellten Zeit der Inaktivität in den "Low Power"-Modus übergeht. ROGER TECHNOLOGY lehnt jede Haftung für Schäden, die durch unsachgemäßen oder nicht bestimmungsgemäßen, den Angaben dieses Handbuchs nicht entsprechenden Gebrauch verursacht werden, ab.

Wir empfehlen die Verwendung von Zubehör, Steuer- und Sicherheitsvorrichtungen ROGER TECHNOLOGY. Insbesondere empfehlen wir, die Lichtschranken der Baureihe **F4ES** oder **F4S** zu installieren.



 Für weitere Informationen, siehe die Installationsanleitung der Automatisierung **BG30**.

3 Aktualisierungen Version P3.00

1. Hinzufügen der Verwaltung des „Low Power“-Modus, der über den neuen Parameter *L* gesteuert wird; dieser Modus erfordert die Verwendung des an das B70/MODLP angeschlossenen Empfängers H93/RX2LP/I
2. Parameter *L* *D* zur Aktivierung/Deaktivierung von B-CONNECT hinzugefügt
3. Parameter *B* *D* hinzugefügt, um den Typ des verwendeten Endschalers zu konfigurieren
4. Neue Display-Meldungen „5E55“, „AcE r“ und „mLP“ für Low-Power-Betriebsituationen hinzugefügt

5. Parameter **AD** hinzugefügt, um die Verwaltung des MASTER/SLAVE-Modus für entgegengesetzte Automatisierungen zu ermöglichen
6. Hinzufügung des Parameters **B9** zur Auswahl des Ziels der Parametereinstellungen, die mit dem am MASTER-Steuergerät angeschlossenen B-CONNECT vorgenommen werden (**B9=00**: MASTER-Ziel; **B9=D I**: SLAVE-Ziel)
7. Neue Alarme für die MASTER/SLAVE-Verwaltung hinzugefügt (COM1...COM4)
8. Neue INFO-Werte für die Überwachung des MASTER/SLAVE-Betriebs hinzugefügt
9. Hinzufügen des Parameters **BB** zur Aktivierung eines zyklischen Aktivierungs-Timers (Testmodus)
10. Verbesserte Verwaltung des persistenten AP-Befehls
11. Verbesserte Verwaltung der Wiedereinschaltfunktion bei Eingriff der Fotozelle (Par. 56)
12. Änderung des Werkwertes von Par. **B5** auf **D3**
13. Umbenennung von Par. **9D** in „**FF**“

4 Technische Daten des Produkts

	BG30/1603 BG30/1604	BG30/2203 BG30/2204	BG30/1003/HS BG30/1004/HS	BG30/1404/R	BG30/1504/HS	BG30/1804/HS	BG30/803/HS BG30/804/HS
VERSORGUNGSSPANNUNG	230 V~ ± 10% 50/60 Hz (115 V~ ± 10% 50/60 Hz) ⁽¹⁾						
VERBRAUCH IM STAND-BY-MODUS	≤ 0.5 W						
VERBRAUCH WÄHREND DES WARTENS AUF BEFEHLE MIT NICHT AKTIVEM STAND-BY	8 W (*)						
MAXIMAL VOM STROMNETZ AUFGENOMMENE LEISTUNG	230 W	190 W	200 W	190 W	240 W	230 W	220 W
ANLAUFLEISTUNG	650 W	470 W	590 W	540 W	650 W	650 W	620 W
SICHERUNGEN	F1 = 20A (ATO257) Schutz des Kraft-Motor Stromkreis F2 = T2A (ATO257) Schutz Primärseite des Transformator F3 = 3A (5x20 mm) Schutz der Zubehör Stromversorgung						
ANSCHLIESSBARE MOTOREN	1						
STROMVERSORGUNG DES MOTORS	36 V~, mit selbstschützendem Wechselrichter						
MOTORTYP	Bürstenloser Sinusmotor (ROGER BRUSHLESS)						
MOTORSTEUERUNG	feldorientiert (FOC), sensed						
NENNLEISTUNG MOTOR	85 W	100 W	140 W	120 W	160 W	160 W	140 W
HÖCHSTLEISTUNG MOTOR	350 W	420 W	530 W	480 W	590 W	590 W	560 W
HÖCHSTLEISTUNG BLINKLEUCHE	25 W						
INTERVALLDAUER BLINKLEUCHE	50%						
HÖCHSTLEISTUNG ZUGANGSBELEUCHTUNG	100 W 230 V~ - 40 W 24 V~/--- (reiner Kontakt)						
LICHTLEISTUNG TOR GEÖFFNET	3 W (24 V---)						
AUSGANGSLEISTUNG FÜR ZUBEHÖR	20 W						
BETRIEBSTEMPERATUR	 -20°C  +55°C						
PRODUKTABMESSUNGEN	Abmessungen in mm 200x90x45 Gewicht: 0,244 kg						



⁽¹⁾ BG30/1603/115 - BG30/1604/115 - BG30/2203/115 - BG30/2204/115 - BG30/1003/HS/115 - BG30/1004/HS/115 - BG30/1504/HS/115 - BG30/1804/HS/115 - BG30/803/HS/115 - BG30/804/HS/115

(*) Richtwert für den Verbrauch ohne angeschlossenes Zubehör, mit eingestecktem Empfänger und ohne elektrische Bremsung der Motoren (falls zutreffend)



Die Summe der Stromaufnahmen aller angeschlossenen Zubehöreile darf nicht die, in der Tabelle angegebenen, maximalen Leistungsdaten überschreiten. Die Daten werden NUR mit Original-Zubehör von ROGER TECHNOLOGY garantiert. Die Verwendung von nicht Original-Zubehör kann zu Funktionsstörungen führen. ROGER TECHNOLOGY übernimmt keine Haftung bei falschen oder nicht geeigneten Installationen. Alle Anschlüsse sind durch Sicherungen geschützt, siehe Tabelle. Die Zugangsbeleuchtung erfordert eine externe Sicherung.

5 Beschreibung der Anschlüsse

Um Zugang zum Klemmbrett für den Anschluss der Steuerungen zu haben, die Abdeckung des Motors abnehmen, wie auf **Abbildung 1** gezeigt:
 In **Abbildung 2-3-4-5** ist das Anschlussschema der Netzspannung an die Steuerkarte des Motors dargestellt.

5.1 Art der Installation

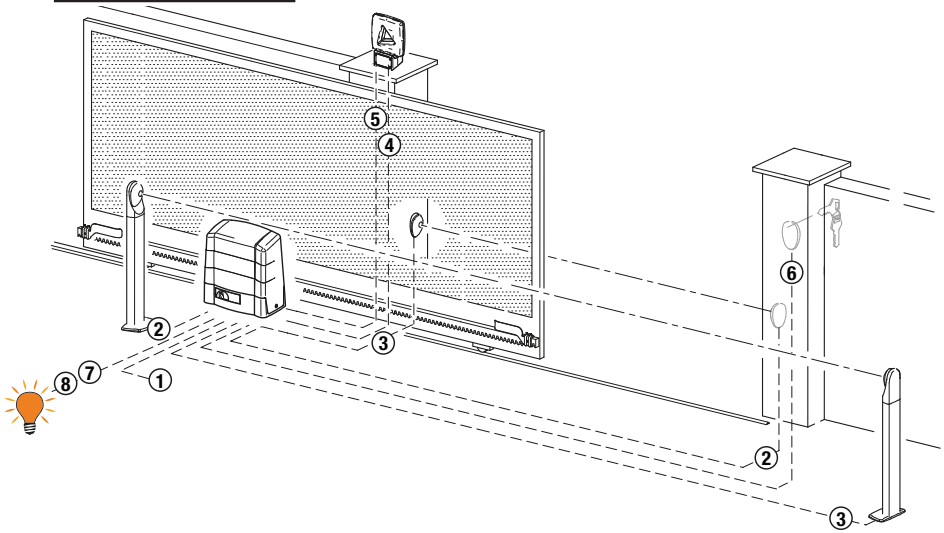

! Es liegt in der Verantwortung des Installateurs, die Eignung der Kabel in Bezug auf die in der Installation verwendeten Geräte und deren technische Eigenschaften zu überprüfen.

		Empfohlene Kabel
1	Stromversorgung	Kabel mit mit doppelt isolierten Typ H07RN-F 3x1,5 mm ²
2	Lichtschränken - Empfänger F4ES/F4S	Kabel 5x0,5 mm ² (Kabellänge Max 20 m)
3	Lichtschränken - Sender F4ES/F4S	Kabel 3x0,5 mm ² (Kabellänge Max 20 m)
4	LED Blinkleuchte FIFTHY/24	Kabel 2x1 mm ² (Kabellänge Max 10 m)
5	Antenna	Kabel 50 Ohm RG58 (Kabellänge Max 10 m)
6	Schlüssel-Wählschalter R85/60	Kabel 3x0,5 mm ² (Kabellänge Max 20 m)
	Numerische Tastatur H85/TTD - H85/TDS (Anschluß auf H85/DEC - H85/DEC2) H85/DEC - H85/DEC2 (Anschluß Steuergerät)	Kabel 2x0,5 mm ² (Kabellänge Max 30 m) Kabel 4x0,5 mm ² (Kabellänge Max 20 m) Die Anzahl der Leiter steigt bei Verwendung von mehr als einem Ausgangskontakt an H85/DEC - H85/DEC2
7	Kontrollleuchte Schwingtor offen	Kabel 2x0,5 mm ² (Kabellänge Max 20 m)
8	Zugangsbeleuchtung (reiner Kontakt)	Kabel 2x1 mm ² (Kabellänge Max 20 m)

i **EMPFEHLUNGEN:** Im Falle schon vorhandener Installationen empfehlen wir, den Querschnitt und den (guten) Zustand der Kabel zu überprüfen.

5.2 Elektrische Anschlüsse

Am Versorgungsnetz einen allpoligen Schalter oder Trennschalter mit Öffnungsabstand der Kontakte von mindestens 3 mm einbauen. Den Trennschalter auf OFF stellen und alle Pufferbatterien trennen, bevor Reinigungs- oder Wartungsarbeiten durchgeführt werden.

Prüfen, ob sich vor der Elektroanlage ein geeigneter Fehlerstromschutzschalter mit Schwellenwert 0,03 A und Überstromschutz befinden, unter Beachtung der technischen Regeln und der geltenden Normen.

Für die Stromversorgung ein elektrisches Kabel vom Typ H07RN-F 3G1.5 verwenden, und mit den Klemmen L (braun), N (blau),  (gelb/grün), die sich im Inneren der Automation befinden, verbinden.

Die Umhüllung des Versorgungskabels nur auf Klemmenhöhe (siehe Bez. A - Abb. 2) abziehen und mit dem speziellen Kabelbinder befestigen.

Mit einem Tester die Spannung in Volt des primären Netzanschlusses prüfen.

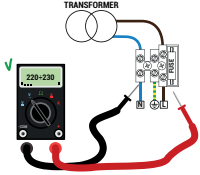

Um die ordnungsgemäße Funktion der Brushless-Antriebe sicherzustellen, muss die primäre Netzstromversorgungsspannung wie folgt sein:

- 230V ~ ±10% für das Steuergerät B70/1DCHP.
- 115V ~ ±10% für das Steuergerät B70/1DCHP/115.

Wenn die erfasste Spannung die oben genannten Daten nicht erfüllt oder nicht stabil ist, könnte die Automatisierung auf NICHT effiziente Weise funktionieren.

i Die Verbindungen zum Stromnetz und zu möglichen Niederspannungsleitungen im Außenbereich der Schalttafel, müssen auf einem unabhängigen Pfad und getrennt von den Anschlüssen zu den Steuer- und Sicherheitseinrichtungen (SELV = Safety Extra Low Voltage) erfolgen. Stellen Sie sicher, dass die Leitungen der Netzstromversorgung und die Leitungen des Zubehörs (24 V) getrennt sind.

	BESCHREIBUNG
	<p>Spannung Netzanschluss 230V ~ ±10%, 50/60 Hz (115V ~ ±10%, 50/60 Hz). Sicherung 5x20 T2A.</p>
	<p>Sekundäreingang des Transformators für die Stromversorgung des Motors mit 26V~ (SEC1) und für die Versorgung der Logikkomponenten und der Peripheriegeräte mit 19V~ (SEC2). ANMERKUNG: Die Verkabelung erfolgt werkseitig von ROGER TECHNOLOGY.</p>
	<p>Anschluss an den bürstenlosen Motor ROGER. Anschluss B72/BRAKE/2 für Ausführungen BG30 High Speed (Siehe Abb.13). ANMERKUNG: Die Verkabelung erfolgt werkseitig von ROGER TECHNOLOGY.</p> <p>Achtung! Wenn die Drähte des Motors von der Klemmleiste abgetrennt werden, muss nach ihrem erneuten Anschluss ein Lernlauf durchgeführt werden (siehe Kapitel 10).</p>
	<p>Anschluss an den Akkusatz B71/BCHP (siehe Abb. 16)</p> <p>i Für weitere Informationen wird auf die Betriebsanleitung B71/BCHP verwiesen.</p>

6 Befehle und Zubehör



Wenn die Sicherheitseinrichtungen mit Öffnerkontakt nicht installiert sind, müssen sie an den Klemmen COM überbrückt oder durch Änderung der Parameter 50, 51, 53, 54, 73 und 74 des erweiterten Menüs deaktiviert werden.

LEGENDE:

Schließerkontakt (NO - normally open).
 Öffnerkontakt (NC - normally closed).

KONTAKT	BESCHREIBUNG
8  9(COR)	Ausgang für Anschluss an die Zugangsbeleuchtung (reiner Kontakt). 230V~ 100 W - 24V~/=== 40 W. HINWEIS: Eine Schutzsicherung vorsehen.
8  9(COR)	Reiner Meldekontakt für: <ul style="list-style-type: none"> • Tor entriegelt / Störung der Batterieversorgung (Batterie fast leer); • Tor vollständig geöffnet / Tor vollständig geschlossen (Abb. 4). Die Betriebsart des COR-Ausgangs wird durch den Parameter 20 gesteuert. Der Spannungspegel der Batterie kann in Parameter 85 eingestellt werden.
10(+SC)  11(COM)	Anschluss Kontrollleuchte Tor offen 24V=== 3 W. Die Funktion der Kontrollleuchte ist vom Parameter AB geregelt.
10(+SC)  11(COM)	Anschluss Lichtschrankenest und/oder Batteriesparbetrieb. Man kann die Stromversorgung der Sender (TX) der Lichtschranken anschließen. Den Parameter AB02 einstellen, um die Testfunktion zu aktivieren. Bei jedem erhaltenen Befehl schaltet das Steuergerät die Lichtschranken aus und ein, um den korrekten Zustandswechsel des Kontakts zu prüfen. Es ist außerdem möglich, die Stromversorgung aller externen Vorrichtungen anzuschließen, um den Verbrauch der Akkus (falls vorhanden) zu reduzieren. AB03 oder AB04 einstellen. ACHTUNG! Wenn man den Kontakt 10(+SC) für den Lichtschrankenest oder den Batteriesparbetrieb verwendet, ist es nicht mehr möglich, eine Kontrollleuchte Tor offen anzuschließen.
12(FT2)  30(COM)	Eingang (Öffner) für den Anschluss von Lichtschranken FT2 (Abb. 5, 6, 7, 8, 9, 10). Die Lichtschranken sind werkseitig mit folgenden Einstellungen konfiguriert: - 5300 . Die Lichtschranke FT2 ist beim Öffnen deaktiviert. - 5400 . Die Lichtschranke FT2 ist beim Schließen deaktiviert. - 5501 . Wenn die Lichtschranke FT2 verdunkelt ist, öffnet sich das Tor bei Erhalt eines Öffnungsbefehls. Wenn die Lichtschranken nicht installiert sind, die Klemmen 30(COM) - 12(FT2) überbrücken oder die Parameter 5300 und 5400 einstellen. ACHTUNG! Wir empfehlen, die Lichtschranken der Baureihe F4ES , oder F4S zu verwenden.
13(FT1)  30(COM)	Eingang (Öffner) für den Anschluss von Lichtschranken FT1 (Abb. 5, 6, 7, 8, 9, 10). Die Lichtschranken sind werkseitig mit folgenden Einstellungen konfiguriert: - 5000 . Die Lichtschranke greift nur beim Schließen ein. Beim Öffnen wird sie ignoriert. - 5102 . Während des Schließens bewirkt das Eingreifen der Lichtschranke die Umkehr der Bewegung. - 5201 . Wenn die Lichtschranke FT1 verdunkelt ist, öffnet sich das Tor bei Erhalt eines Öffnungsbefehls. Wenn die Lichtschranken nicht installiert sind, die Klemmen 30(COM) - 13(FT1) überbrücken oder die Parameter 5000 und 5102 einstellen. ACHTUNG! Wir empfehlen, die Lichtschranken der Baureihe F4ES , oder F4S zu verwenden.
14(COS2)  16(COM)	Eingang (Öffner oder 8 kOhm) für den Anschluss der Sicherheitsleiste COS2 . Die Sicherheitsleiste ist werkseitig mit folgenden Einstellungen konfiguriert: - 7400 . Die Sicherheitsleiste COS2 (Öffnerkontakt) ist deaktiviert. Wenn die Sicherheitsleiste nicht installiert ist, die Klemmen 14(COS2) - 16(COM) überbrücken oder den Parameter 7400 einstellen.
15(COS1)  16(COM)	Eingang (Öffner oder 8 kOhm) für den Anschluss der Sicherheitsleiste COS1 . Die Sicherheitsleiste ist werkseitig mit folgenden Einstellungen konfiguriert: - 7300 . Die Sicherheitsleiste COS1 (Öffnerkontakt) ist deaktiviert. Wenn die Sicherheitsleiste nicht installiert ist, die Klemmen 15(COS1) - 16(COM) überbrücken oder den Parameter 7300 einstellen.
17(ST)  16(COM)	Eingang STOPP-Befehl (Öffner). Die Öffnung des Sicherheitskontaktes verursacht das Anhalten der Bewegung. HINWEIS: Der Kontakt wird werkseitig von ROGER TECHNOLOGY überbrückt.
22  21(ANT)	Anschluss Antenne für steckbaren Funkempfänger. Wenn man die äußere Antenne benutzt, das Kabel RG58 verwenden; empfohlene maximale Länge: 10 m. HINWEIS: Das Kabel ohne Verbindungsstellen verwenden.
24(ORO)  23(COM)	Eingang Zeitgebung Uhr (Schließerkontakt - NO). Wenn man die Funktion Uhr aktiviert, öffnet sich das Tor und bleibt geöffnet. Nach Ablauf der vom externen Gerät (Uhr) programmierten Zeit das Tor schließt sich. Die Funktion des Befehls wird vom Parameter 80 geregelt.

DE

KONTAKT	BESCHREIBUNG
25(AP) 23(COM) 	Eingang Öffnungsbefehl (Schließerkontakt - NO). ACHTUNG: Bei dauerhafter Aktivierung des Öffnungsbefehls ist die automatische erneute Schließung nicht möglich; die Zeitzählung der automatischen erneuten Schließung beginnt wieder bei Loslassen des Öffnungsbefehls.
26(CH) 23(COM) 	Eingang Schließbefehl (Schließer).
27(PP) 23(COM) 	Eingang Befehl Schrittbetrieb (Schließer). Die Funktion des Befehls ist vom Parameter P4 geregelt.
28(PED) 23(COM) 	Eingang des Befehls zur Teilöffnung (Schließerkontakt - NO). Werkseitig auf 50% der Gesamtöffnung eingestellt.
29(+24V) 30(COM)	Stromversorgung für externe Geräte. Siehe technische Daten. Versorgungsanschluss B72/BRAKE/2 für Ausführungen BG30 High Speed.
31(LAM) 30(COM) 	Anschluss Blinkleuchte (24V $\overline{\text{---}}$ - Einschaltdauer 50%). Man kann die Einstellungen des Vorblinkens über den Parameter P5 und den Blinkmodus über den Parameter 7B einstellen.
ENC	Steckverbinder für den Anschluss an den am Motor installierten Encoder. ACHTUNG! Das Kabel des Encoders nur ohne Netzspannung abtrennen und anschließen. ANMERKUNG: Die Verkabelung erfolgt werkseitig von ROGER TECHNOLOGY.
FC	Steckverbinder (Öffnerkontakte - NC) für den Anschluss des mechanischen (siehe Abbildung 14 - Detail B) oder magnetischen (siehe Abbildung 15 - Detail C) Endschalters. Die Endschalter so einstellen, dass das Tor nach der Aktivierung kurz vor dem mechanischen Anschlag zum Stillstand kommt. ACHTUNG: Bei jeder Veränderung der Einstellung der Endschalter den Lernlauf wiederholen. ANMERKUNG: Die Verkabelung erfolgt werkseitig von ROGER TECHNOLOGY.
SB	Steckverbinder (NC) für den Anschluss des Freigabekontakts. Wenn man den Entriegelungsgriff des Motors öffnet, hält das Tor an und nimmt keine Befehle an. Nachdem der Entriegelungsgriff wieder geschlossen und der Schlüssel in die Schließstellung gedreht wurde, startet die Steuereinheit, wenn sich das Tor in Zwischenposition befindet, das Verfahren zur Kontrolle der Position (siehe Kapitel 20). ANMERKUNG: Die Verkabelung erfolgt werkseitig von ROGER TECHNOLOGY.
RECEIVER CARD H93/RX2LP/I	Steckverbinder für steckbaren Funkempfänger. Das Steuergerät hat werkseitig zwei Fernsteuerfunktionen über Funk eingestellt: <ul style="list-style-type: none"> • PR1 - Befehl Schrittbetrieb (veränderbar über den Parameter 7E). • PR2 - Teilöffnungsbefehl (veränderbar über den Parameter 77). Die Programmierungstasten PR1 und PR2 sind auch bei geschlossener Abdeckung zugänglich (siehe Abb. 10). Der Empfänger ist mit dem Modul B70/MODLP über eine 3-Leiter-Verkabelung verbunden (die Verkabelung wird werkseitig von ROGER TECHNOLOGY hergestellt) und ist für die Verwaltung des „Low Power“-Modus unerlässlich. ACHTUNG! Der H93/RX2LP/I darf nicht durch andere Modelle von ROGER-Steckempfängern ersetzt werden.
AKKULADEGERÄT B71/BCHP AKKUSATZ 2x12V $\overline{\text{---}}$ 4,5 Ah Solo tipo AGM Version HW 02: fügt Spannungsbegrenzer hinzu, nur für High Speed und Reversibel Versionen	Die Verwendung des Ladegeräts und der Pufferbatterien ist nur möglich, wenn der Energiesparmodus (L I $\overline{\text{DD}}$) deaktiviert ist. Steckverbinder für steckbare Akkuladekarte. Bei Ausfall der Netzspannung wird die Steuereinheit von den Akkus gespeist, das Display zeigt bRLt an und die Blinkleuchte wird vo0rübergehen aktiviert, bis die Leitung wieder hergestellt ist oder bis die Spannung der Akkus unter die Sicherheitsschwelle absinkt. Das Display zeigt bLQ (Akku schwach) an und die Steuereinheit nimmt keine Befehle an. Wenn die Netzspannung während der Bewegung das Tor ausfällt, so bleibt das Tor stehen und führt die unterbrochene Bewegung nach 2 Sekunden automatisch fort. Um den Akkuverbrauch zu reduzieren, kann man das Plus der Stromversorgung der Lichtschranksender an die Klemme SC anschließen (siehe Abb. 6-7-8-9). ABD3 oder ABD4 einstellen. Auf diese Weise unterbricht die Steuereinheit, wenn das Tor ganz geöffnet oder ganz geschlossen ist, die Stromversorgung zu den Vorrichtungen. ACHTUNG! Damit sie wiederaufgeladen werden können, müssen die Akkus immer an die elektronische Steuereinheit angeschlossen sein. Prüfen Sie regelmäßig, mindestens alle 6 Monate, die Leistungsfähigkeit des Akkus. Für weitere Informationen wird auf das Installationshandbuch des Akkuladegeräts B71/BCHP verwiesen. In den B70/1DCHP Steuergeräten für High Speed und Reversibel Motoren ist der B72/CL Spannungsbegrenzer eingebaut (von Roger Technology). Falls Sie das Batterieladegerät für High Speed Motoren benötigen, müssen Sie die Version HW 02 haben, da sie diesen Begrenzer integriert.
WIFI	Anschluss für B74/BCONNECT WiFi IP Gerät. Dieses IP-Gerät ermöglicht über einen beliebigen Internetbrowser die vollständige Verwaltung der Zentrale sowohl in der Nähe (Punkt-zu-Punkt-Verbindung) als auch über die Cloud (Fernverbindung).