

LADY LADY 5

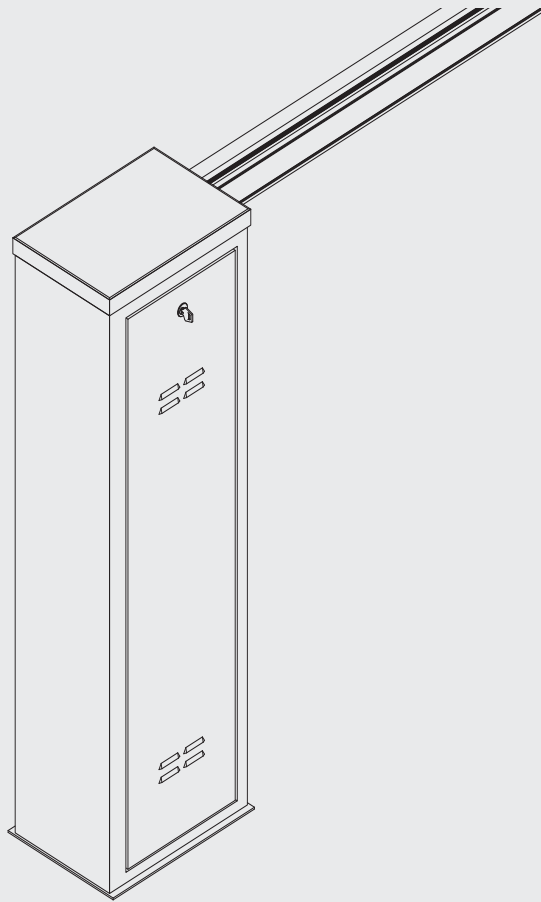

BENINCA[®]
TECHNOLOGY TO OPEN



1

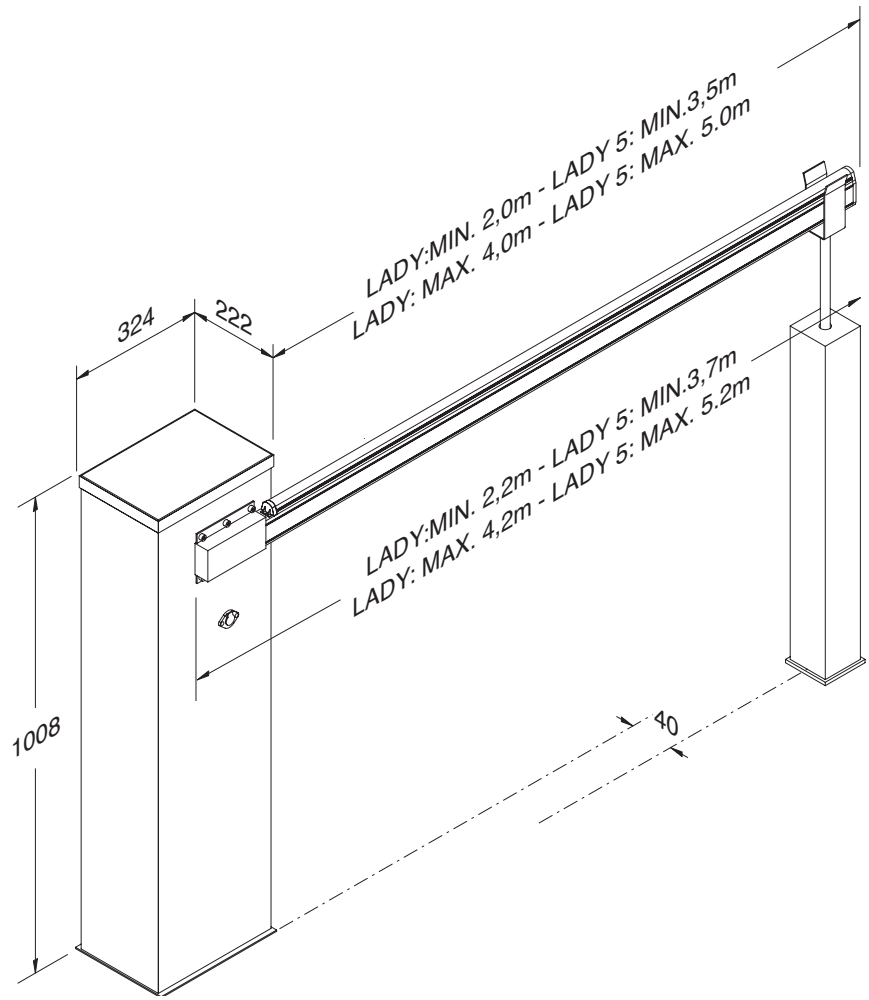

2

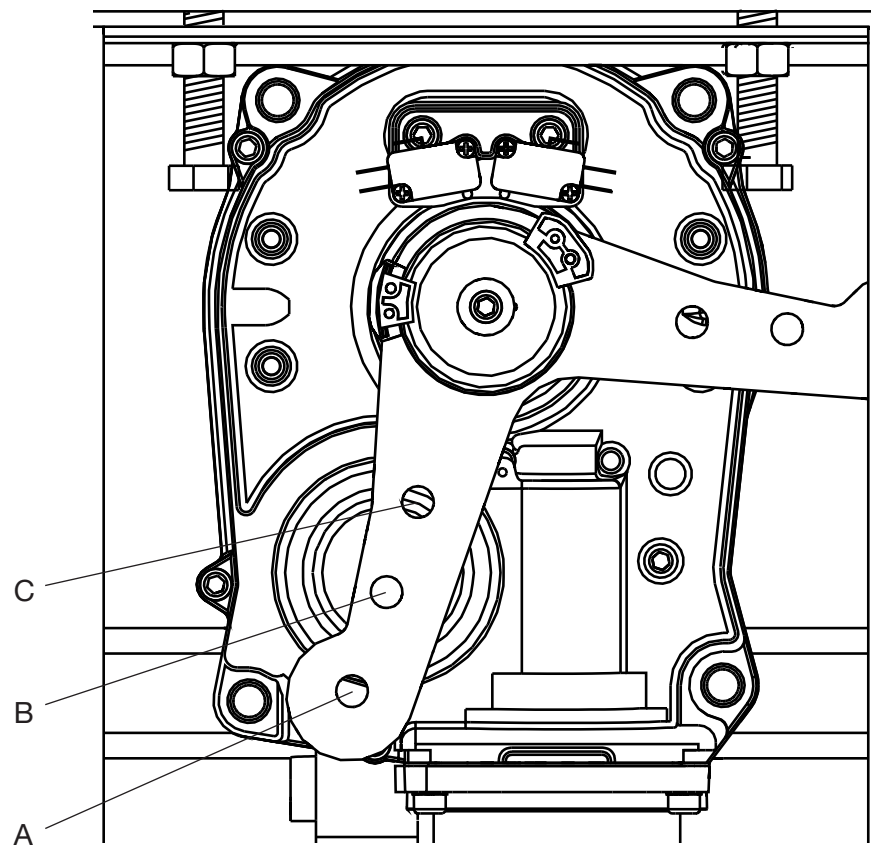

3

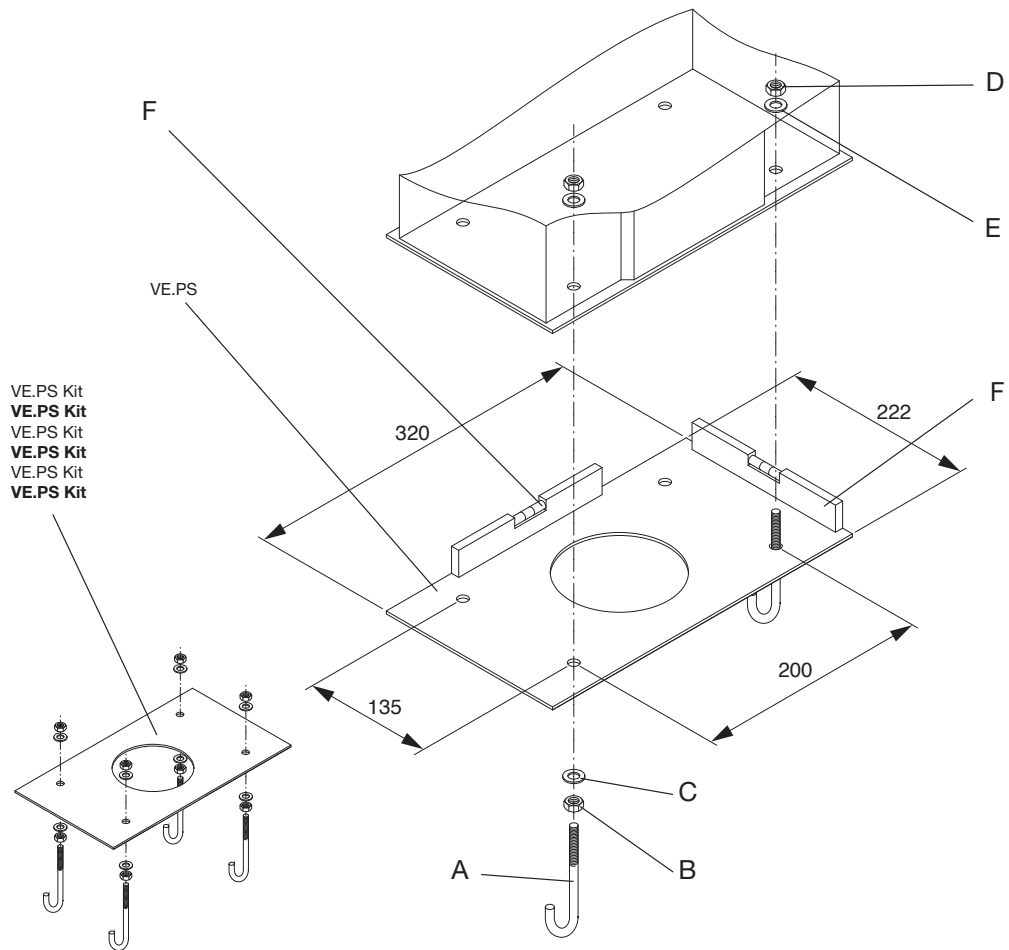

4

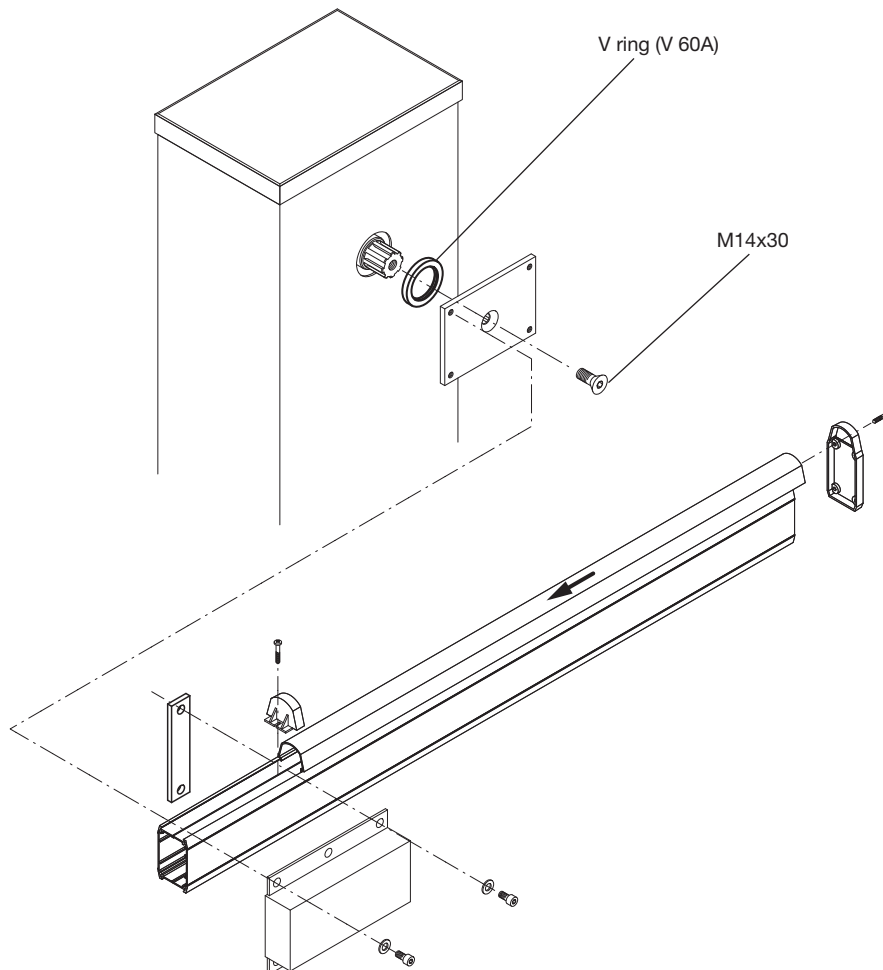

5

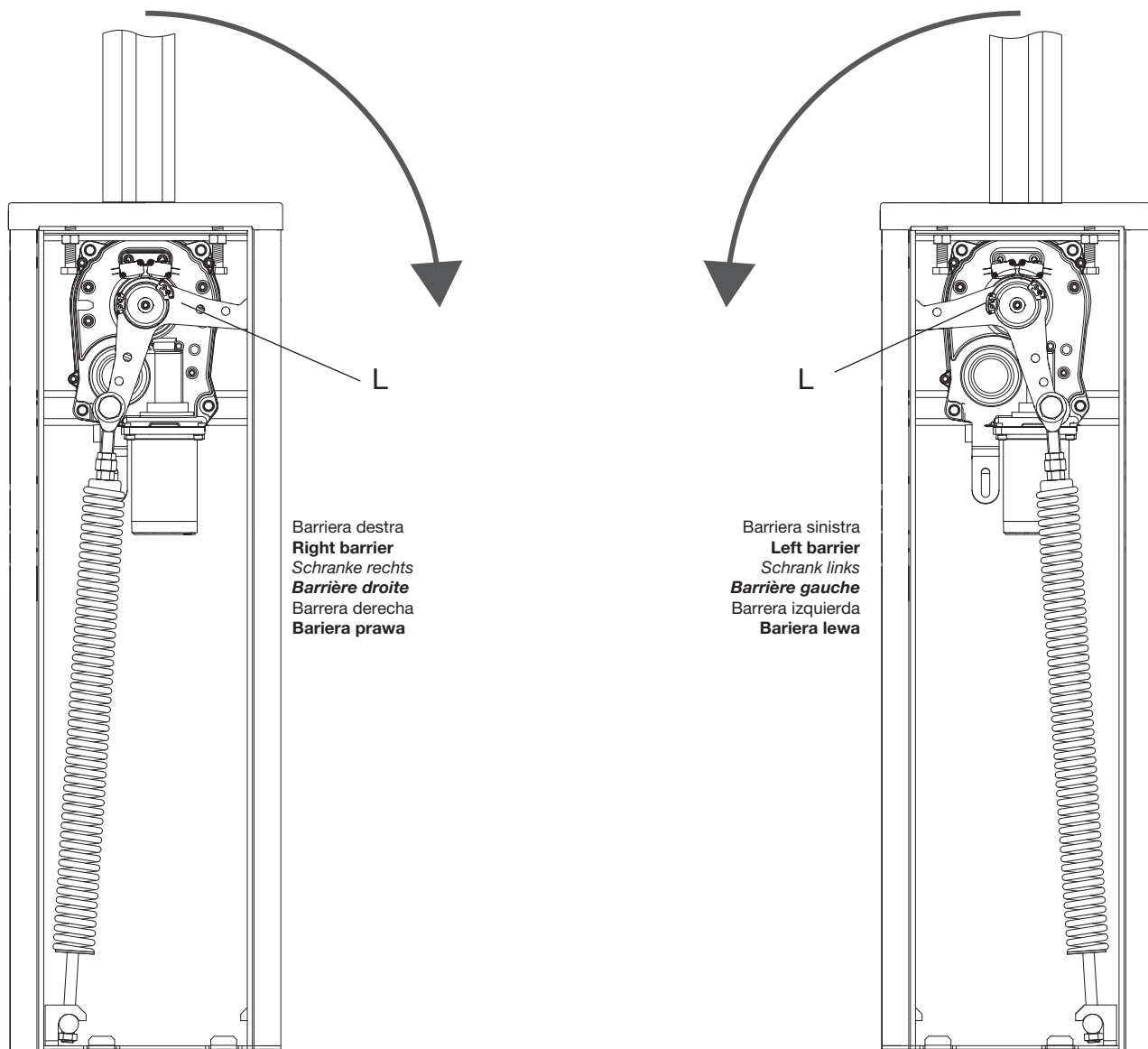

Barriera destra
Right barrier
 Schranke rechts
Barrière droite
 Barrera derecha
Bariera prawa

Barriera sinistra
Left barrier
 Schrank links
Barrière gauche
 Barrera izquierda
Bariera lewa

6

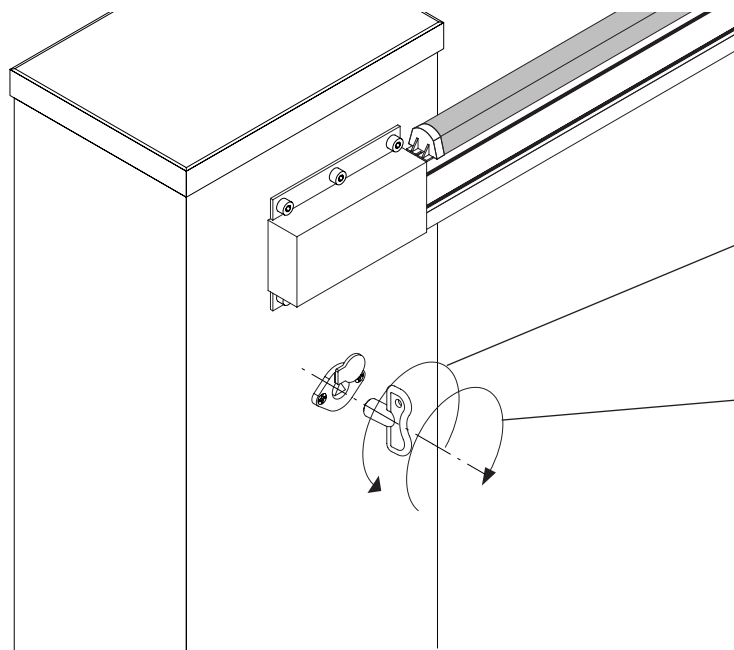

Ripristino automatico
Reset automation
 Reset des Automatismus
Réinitialisation automatisme
 Reactivación del automatismo
Przywrócenie działania automatyzmu

Sblocco di emergenza
Emergency release
 Notentriegelung
Débloccage de secours
 Desbloqueo de emergencia
Rozsprężlanie awaryjne

7

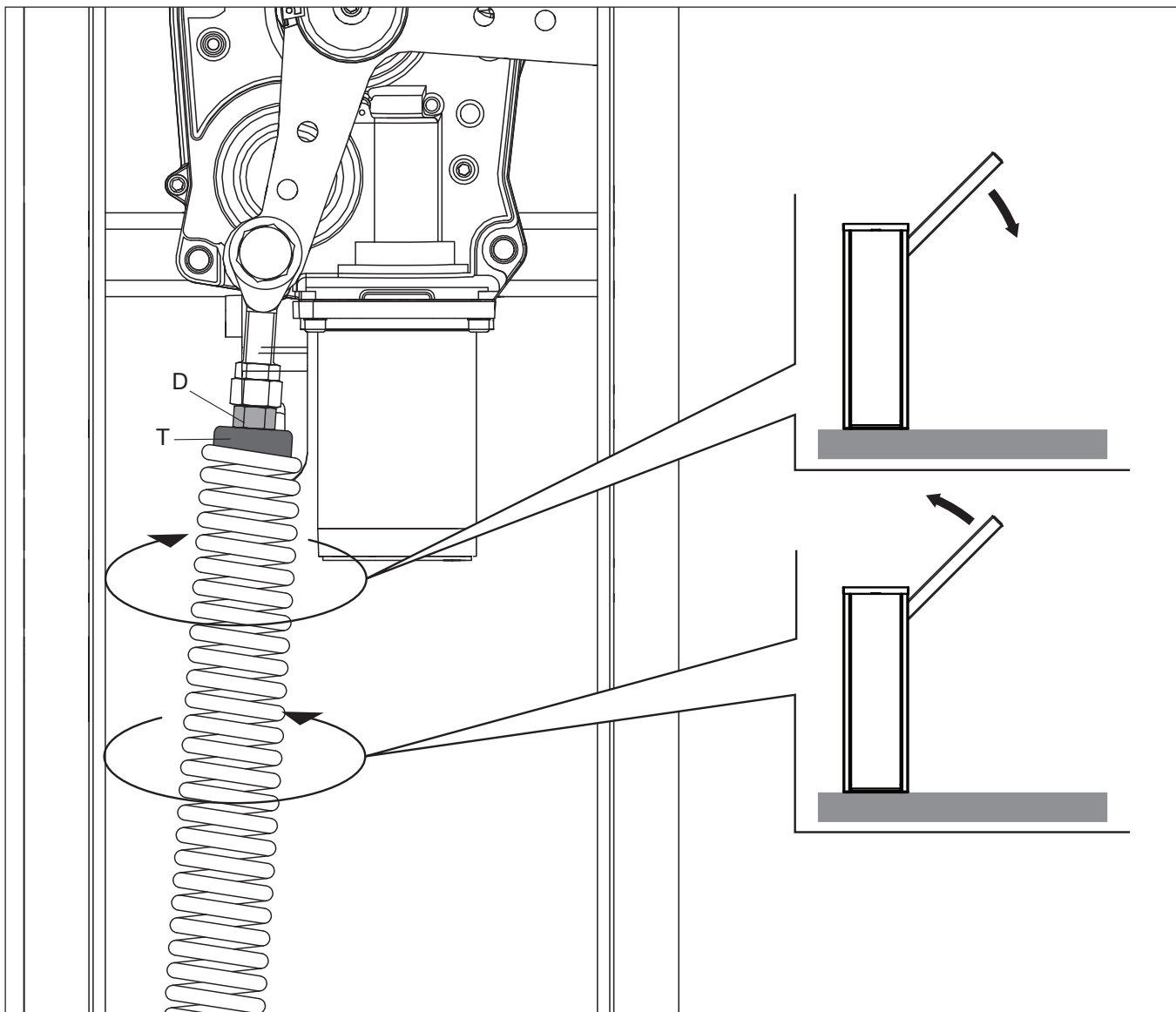

8

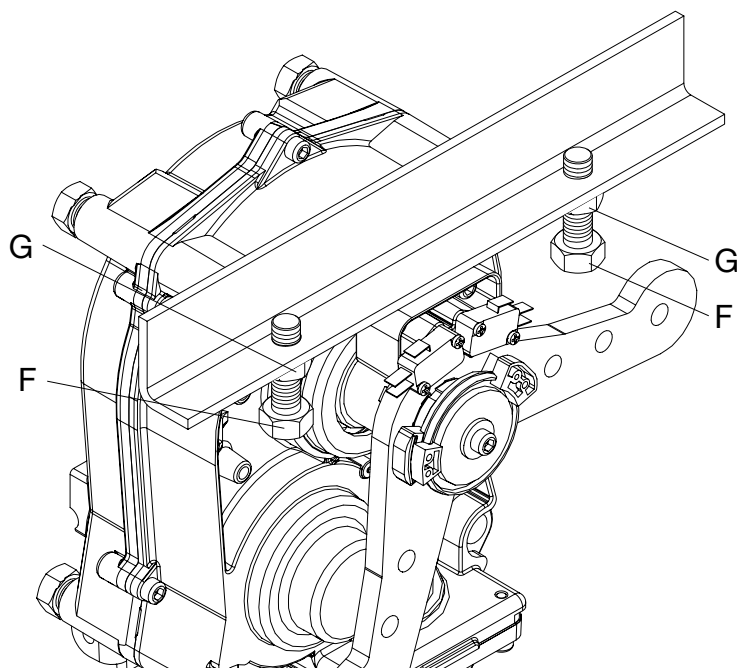

9

○ Slow-down
Open (5L da)

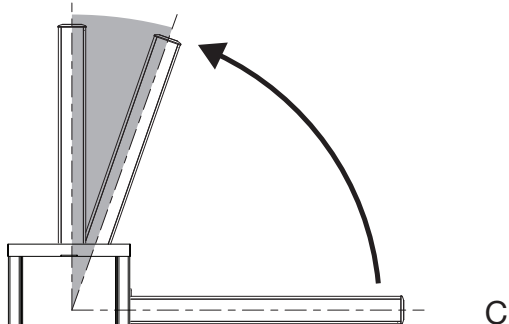

10

○

Slow-down
Close (5L dc)

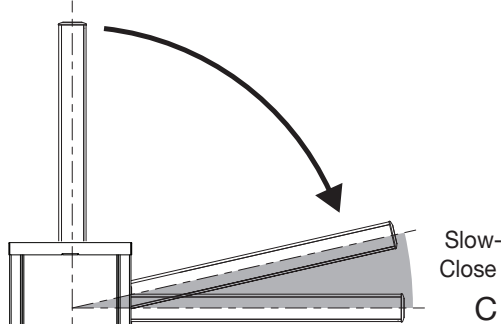

11

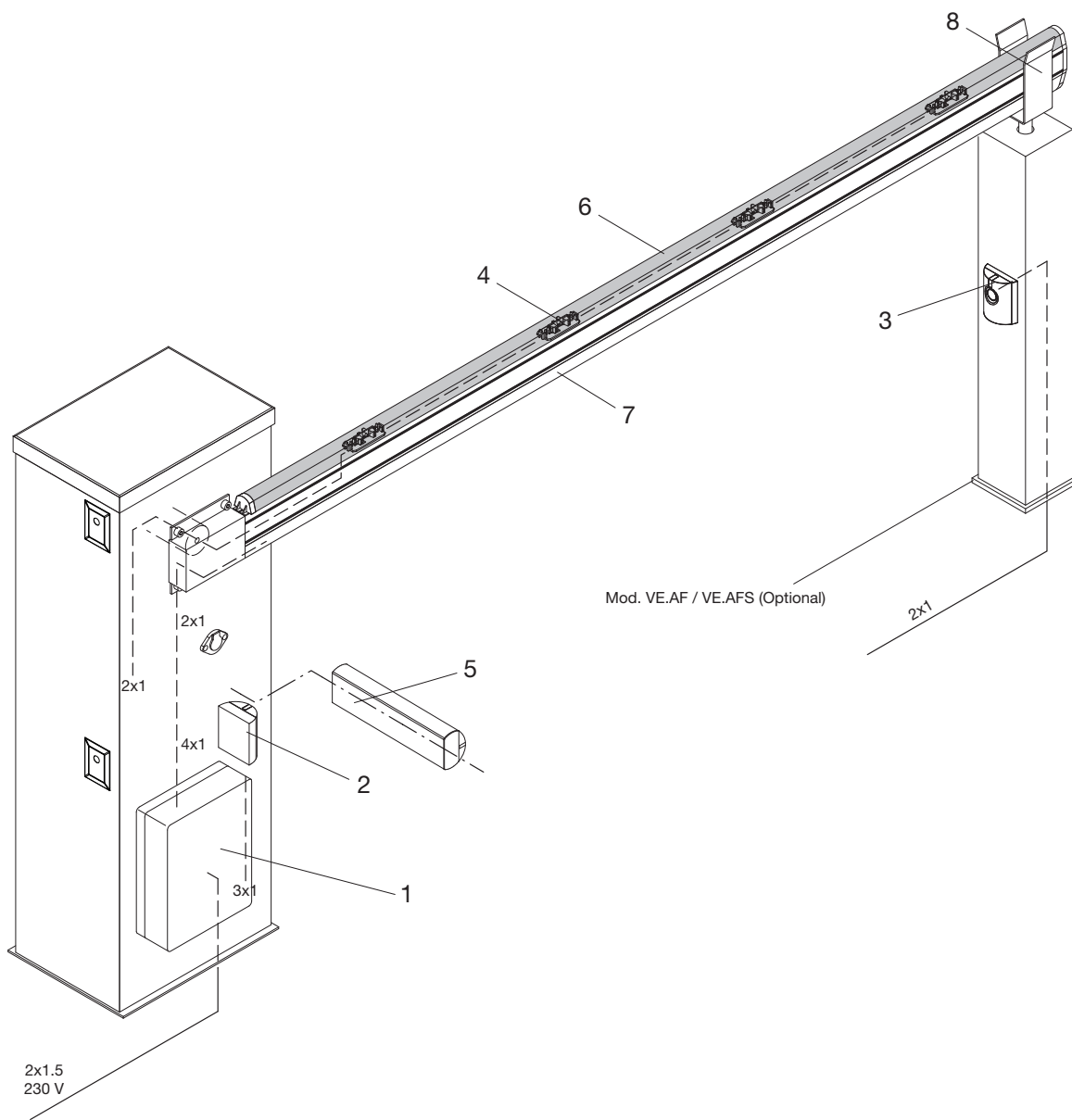

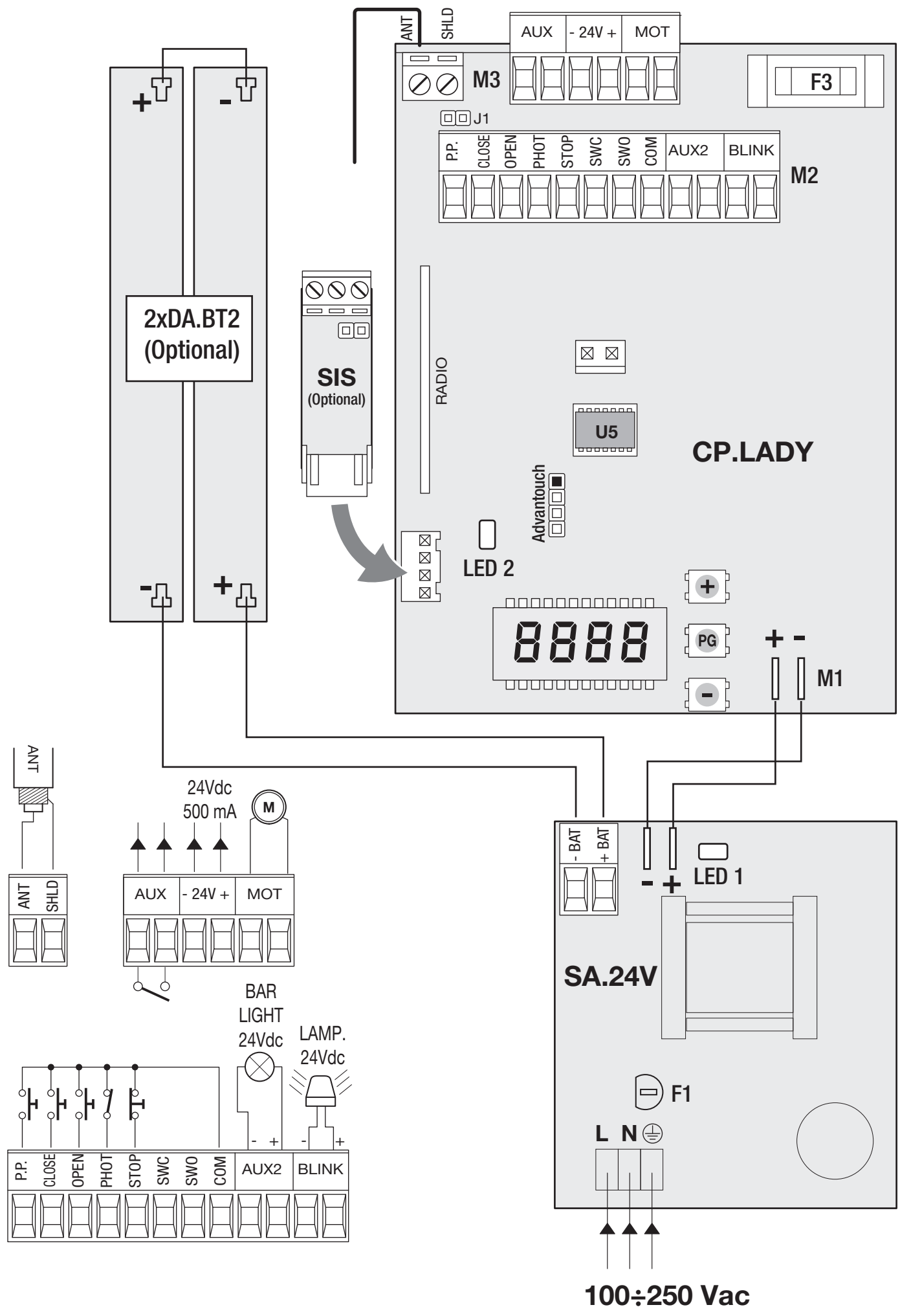

Schema menu di programmazione - Menu programming layout
 Diagramm Programmiermenü - Menu de programmation
 Menü de la carta de programación - Uklad menu programowania

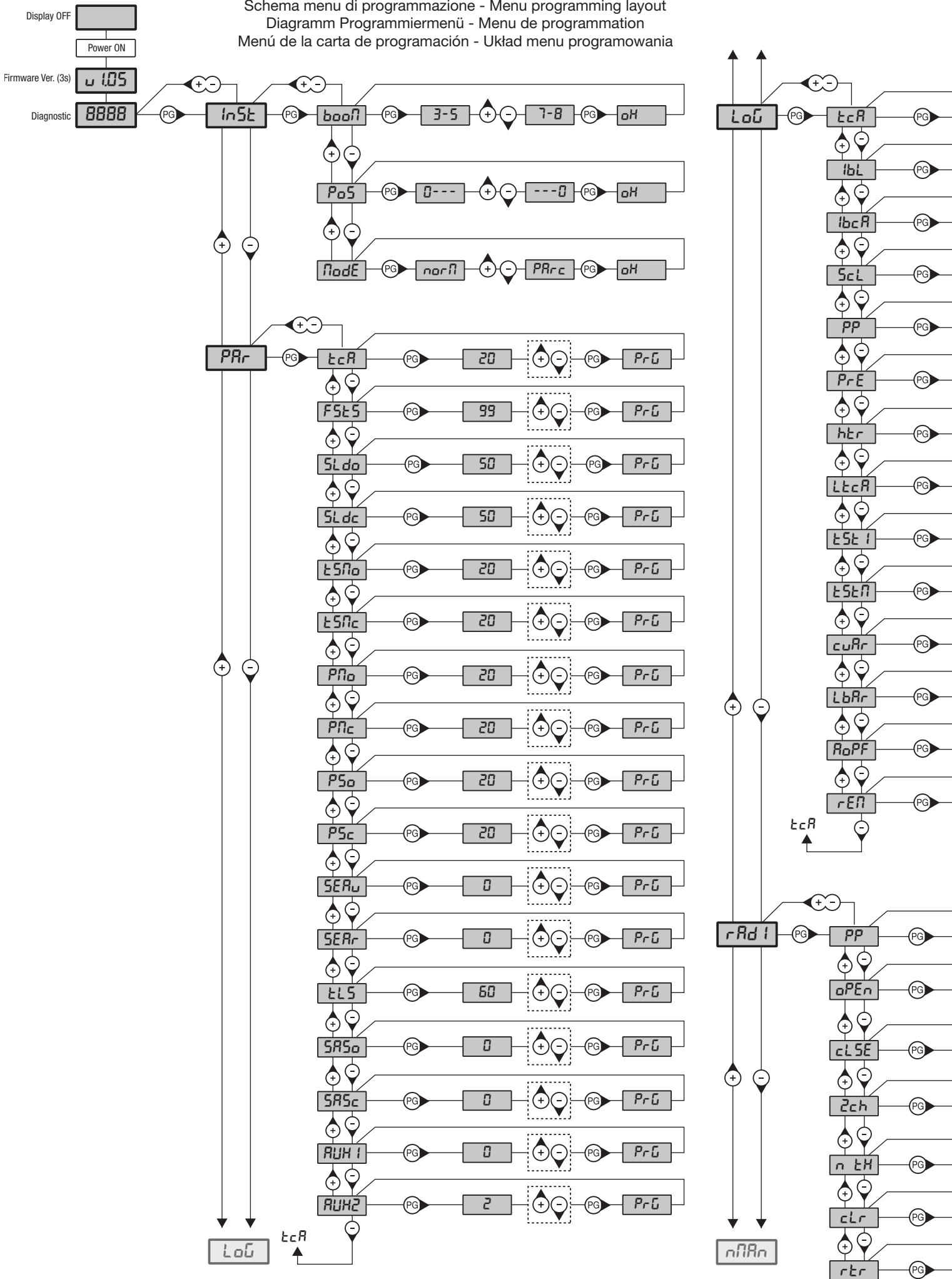

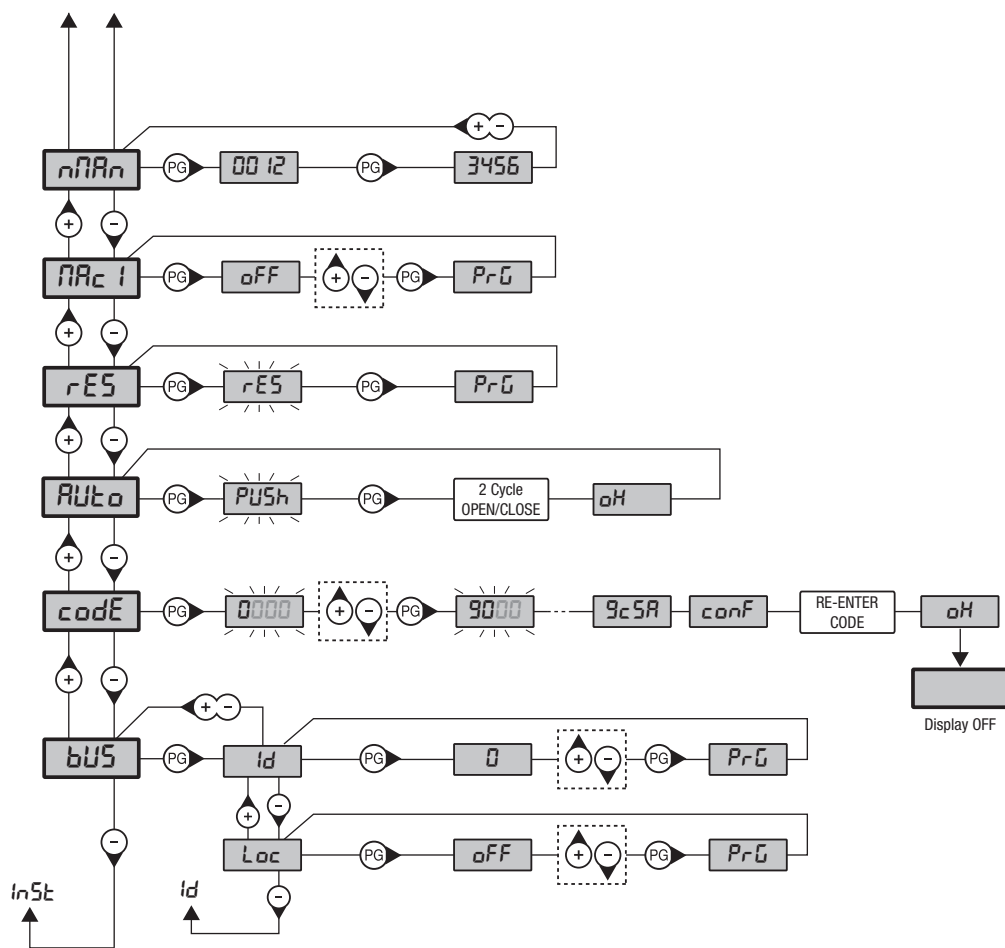
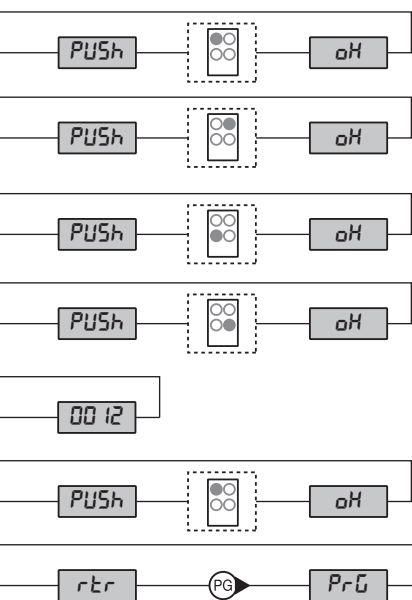
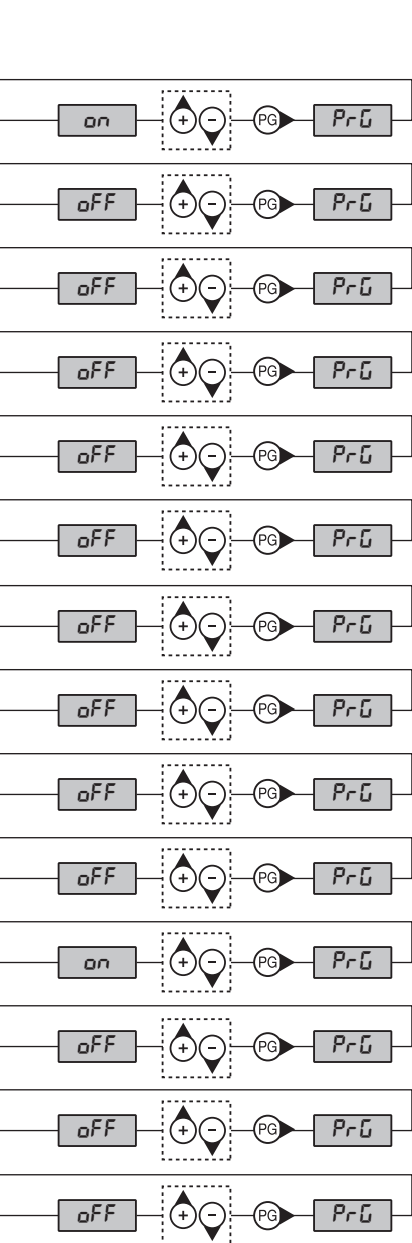

Legenda

	Premere il tasto (-) / Press key (-) / Die Taste (-) drücken Appuyez sur la touche (-) / Presionar la tecla (-) / Wcisnąć przycisk (-)
	Premere il tasto (+) / Press key (+) / Die Taste (+) drücken Appuyez sur la touche (+) / Presionar la tecla (+) / Wcisnąć przycisk (+)
	Premere il tasto (PG) / Press key (PG) / Die Taste (PG) drücken Appuyez sur la touche (PG) / Presionar la tecla (PG) / Wcisnąć przycisk (PG)
	Premere simultaneamente (+) e (-) / Press simultaneously keys (+) and (-) Gleichzeitig (+) und (-) drücken / Presser simultanément (+) et (-) Presionar simultáneamente (+) y (-) / Naciskać jednocześnie (+) i (-)
	Selezionare il valore desiderato con i pulsanti (+) e (-) Increase/decrease the value with keys (+) and (-) Mit den Tasten (+) und (-) kann man eingerichtete Werte ändern Régler la valeur désirée avec les touches (+) et (-) Establecer con las teclas (+) y (-) el valor deseado Nastawia przyciskami (+) i (-) obraną wartoś
	Selezionare il pulsante del trasmettitore da associare alla funzione Press the transmitter key, which is to be assigned to function Taste des Sendegeräts drücken, dem diese Funktion zugeteilt werden soll. Appuyer sur la touche du transmetteur qu'e l'on désire affecter à cette fonction. Presionar la tecla del transmisor que se desea asignar a esta función. Wcisnąć przycisk nadajnika, który zamierza się skojarzyć z tą funkcją.

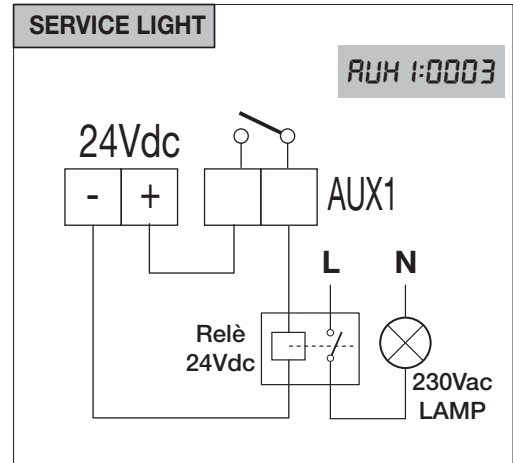
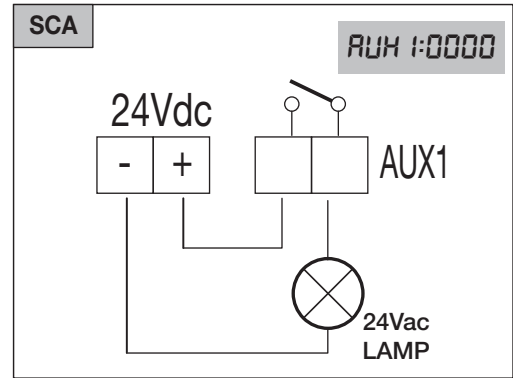
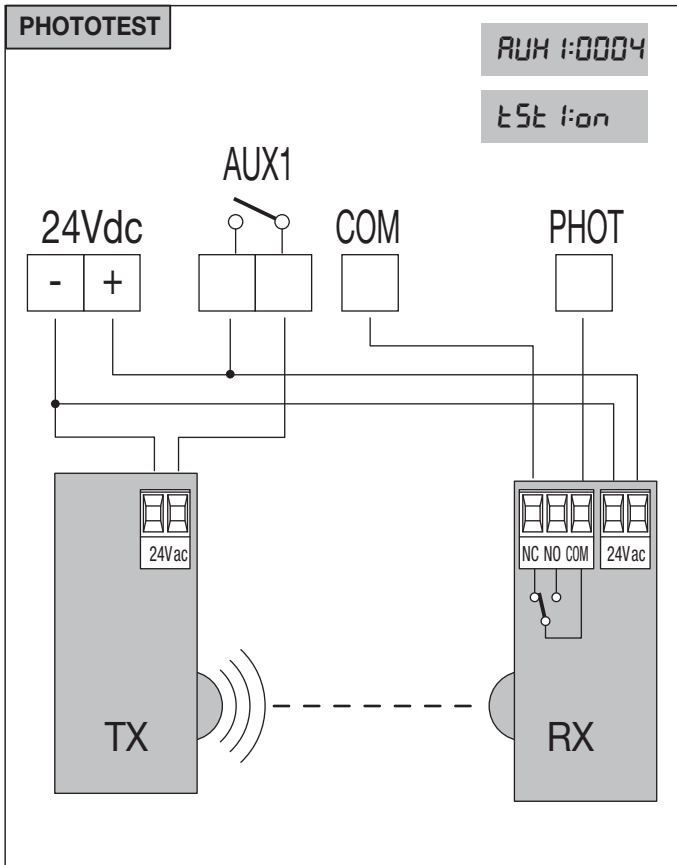

MASTER
Menu *bus*
id=0

SLAVE
Menu *bus*
id=1

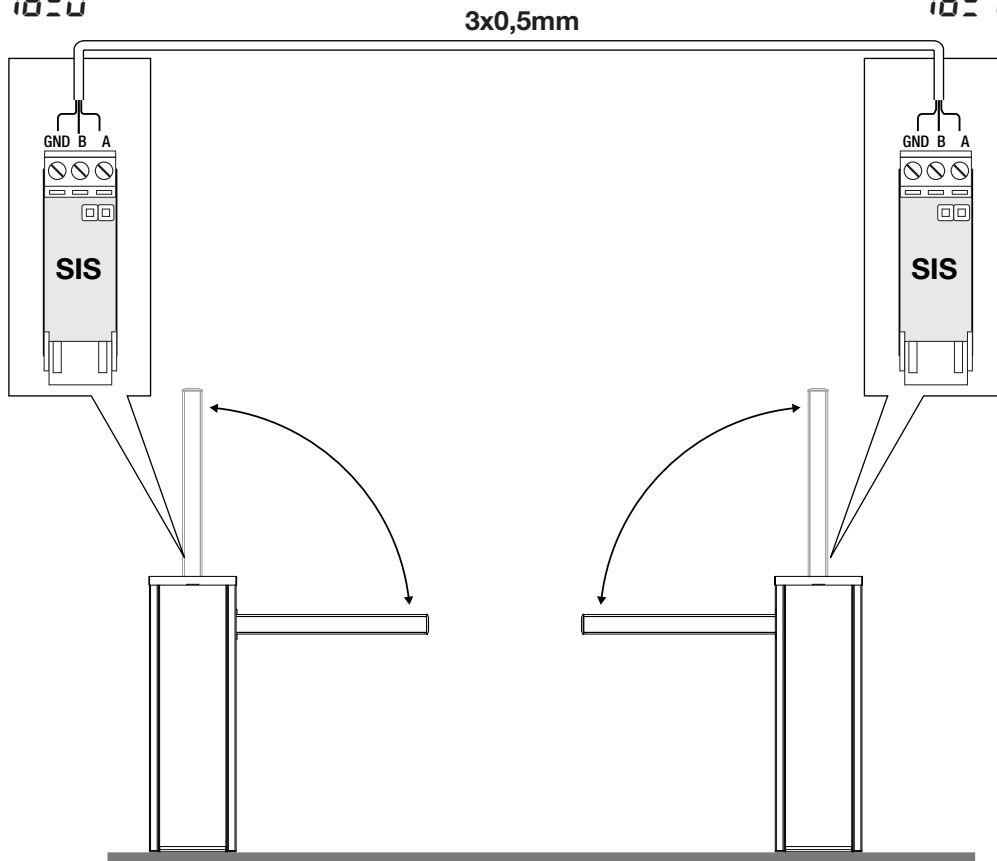

INDEX	
1) DESCRIPTION.....	21
2) DIMENSIONS.....	21
3) ARC COMPATIBLE CONTROL UNIT	21
4) POSITIONING THE SPRING AND THE ACCESSORIES FOR USE	22
5) INSTALLATION OF THE OPTIONAL FOUNDATION PLATE VE.PS (FIG.3)	22
6) FIXING THE BAR (FIG.4)	22
7) PREPARING THE BARRIER FOR RIGHT OR LEFT (FIG.5).....	22
8) MANUAL AND EMERGENCY MANOEUVRES (FIG. 6)	23
9) BALANCING (FIG. 7).....	23
10) REGULATING THE MECHANICAL STOPS (FIG.8).....	23
11) WIRE DIAGRAM (FIG.11)	23
12) CP.LADY CONTROL UNIT WIRE DIAGRAM	23
13) PROGRAMMING	24
13.1) TO ACCESS PROGRAMMING	24
13.2) PROGRAMMING NOTES	24
14) PARAMETERS, LOGICS AND SPECIAL FUNCTIONS.....	24
14.1) INSTALLATION (<i>inSt</i>).....	24
14.2) PARAMETERS (<i>PRr</i>).....	24
14.3) LOGICS (LOG)	25
14.4) RADIO (<i>rAd t</i>).....	26
14.5) CYCLES NUMBER (<i>nPRn</i>).....	26
14.6) MAINTENANCE CYCLES (<i>PRc t</i>).....	26
14.7) RESET (<i>rE5</i>).....	27
14.8) AUTOSET (<i>PRto</i>).....	27
14.9) PASSWORD (<i>codE</i>).....	27
14.10) SYNCHRONIZATION (<i>bU5</i>).....	27
15) SYNCHRONIZATION OF TWO OPPOSED BARRIERS	27
16) TRANSMITTERS REMOTE LEARNING	27
17) FUSES	28
18) BACK UP BATTERIES.....	28
19) DIAGNOSTICS	28
20) ERROR MESSAGES	28

ENG

WARNING



GENERAL INFORMATIONS

The product shall not be used for purposes or in ways other than those for which the product is intended for and as described in this manual. Incorrect uses can damage the product and cause injuries and damages. The company shall not be deemed responsible for the non-compliance with a good manufacture technique of gates as well as for any deformation, which might occur during use. Keep this manual for further use.



INSTALLER GUIDE

This manual has been especially written to be use by qualified fitters. Installation must be carried out by qualified personnel (professional installer, according to EN 12635), in compliance with Good Practice and current code. Make sure that the structure of the gate is suitable for automation. The installer must supply all information on the automatic, manual and emergency operation of the automatic system and supply the end user with instructions for use.



GENERAL WARNINGS

Packaging must be kept out of reach of children, as it can be hazardous. For disposal, packaging must be divided the various types of waste (e.g. carton board, polystyrene) in compliance with regulations in force. Do not allow children to play with the fixed control devices of the product. Keep the remote controls out of reach of children. This product is not to be used by persons (including children) with reduced physical, sensory or mental capacity, or who are unfamiliar with such equipment, unless under the supervision of or following training by persons responsible for their safety. Apply all safety devices (photocells, safety edges, etc.) required to keep the area free of impact, crushing, dragging and shearing hazard. Bear in mind the standards and directives in force, Good Practice criteria, intended use, the installation environment, the operating logic of the system and forces generated by the automated system. Installation must be carried out using safety devices and controls that meet standards EN 12978 and EN 12453. Only use original accessories and spare parts, use of non-original spare parts will cause the warranty planned to cover the products to become null and void. All the mechanical and electrical parts composing automation must meet the requirements of the standards in force and outlined by CE marking.



ELECTRICAL SAFETY

The box containing the control unit is secured to barrier case with two screws to avoid damage during transport. Once the barrier has been positioned it possible to remove the screws and to unhook the box from the case so as to facilitate wiring operations and the preparation of the control unit. On completing installation, secure the box to the barrier case again.

An omnipolar switch/section switch with remote contact opening equal to, or higher than 3mm must be provided on the power supply mains. Make sure that before wiring an adequate differential switch and an overcurrent protection is provided.

Pursuant to safety regulations in force, some types of installation require that the gate connection be earthed. During installation, maintenance and repair, cut off power supply before accessing to live parts. Also disconnect buffer batteries, if any are connected. The electrical installation and the operating logic must comply with the regulations in force. The leads fed with different voltages must be physically separate, or they must be suitably insulated with additional insulation of at least 1 mm. The leads must be secured with an additional fixture near the terminals. During installation, maintenance and repair, interrupt the power supply before opening the lid to access the electrical parts. Check all the connections again before switching on the power. The unused N.C. inputs must be bridged.

Consult the control unit instructions manual as regards the regulation of the operating times and logic, the connection of the accessories and of the safety devices, etc.



WASTE DISPOSAL

As indicated by the symbol shown, it is forbidden to dispose this product as normal urban waste as some parts might be harmful for environment and human health, if they are disposed of incorrectly. Therefore, the device should be disposed in special collection platforms or given back to the reseller if a new and similar device is purchased. An incorrect disposal of the device will result in fines applied to the user, as provided for by regulations in force.

Descriptions and figures in this manual are not binding. While leaving the essential characteristics of the product unchanged, the manufacturer reserves the right to modify the same under the technical, design or commercial point of view without necessarily update this manual.

QUICK PROGRAMMING

- Press the <PG> button, the display goes to the "INST" menu
- Enter the INST menu
- Verify that the parameter BOOM is correct: 3-5 for all LADY/LADY 5 models (factory settings).
- Set the barrier position by means of the menu POS, by default the barrier is set as RIGHT BARRIER
- Enter the menu AUTO, confirm with <PG> and wait until the barrier has carried out the autose of the parameters
- By means of the menus PAR and LOG, select the parameters and the logic functions wanted according to the type of installation in object

IMPORTANT: After every change of the parameters FSTS, SLDO, SLDC, TSMO, TSMC, the barrier executes an opening maneuver followed by a closing one in order to acquire the new values of current and torque, on the screen will appear the message <PRG>

1) DESCRIPTION

Road barrier provided with built in control unit CP.LADY and quick external release for manual maneuver.

It is possible the synchronization of 2 motors for controlling 2 opposed barriers, to do this it is necessary to use the synchronization control unit SIS (optional). Wire each other the two control units as shown in figure 14 and configure them as described in the paragraph "Synchronization of two opposed barriers". In addition to this it is possible the connection of two backup batteries by 12V 2,1Ah (DA.BT2), as shown in figure 12.

The barrier can work also in absolute absence of power supply by means of the accessory KSUN (sun system composed by solar panel, backup batteries and control unit).

Every utilization different from the one described in this instruction manual is not allowed and voids the manufacturer warranty.

We would like to remind you that if you register on the site www.automatismicab.com you will have access to the technical documentation updated for all the products and accessories and the guide for compiling the technical file and documents required under Annex V of the Machinery Directive, mandatory under the regulations in force.

IMPORTANT: whether the barrier is used even for pedestrian passage it is compulsory to carry out the force test as indicated by the European standard EN12445 (see the limitations as per the standard EN12453).

In case the passage is for vehicular use only, it is necessary to foresee appropriate signs of pedestrian prohibition.

2) DIMENSIONS

In figure 1 are shown the main dimensions of the LADY barrier.

Overall dimensions are expressed in mm.

LADY

The road barrier length ranges from 2,2m minimum to 4,2m maximum.

As about 20cm are required to fix a road barrier, a useful opening of passage, ranging from 2.0m to 4.00m, will be available, as shown in Fig.1 LADY 5

The road barrier length ranges from 3,7m minimum to 5,2m maximum.

As about 20cm are required to fix a road barrier, a useful opening of passage, ranging from 3,5m to 5,0m, will be available, as shown in Fig.1

Optional accessories can be fitted onto be barrier (photocells, selector, etc.). For assembly, apply the special covers supplied (Rif. A).

SPECIFICATION	LADY
Power supply	100-250 Vac 50/60Hz
Motor power supply	24Vdc
Current absorption	1,5 A
Stand by current absorption	40 mA (230 Vac - 50 mA (115 Vac)
Torque	195 Nm
Opening time	min. 3,6"
Jogging	Continuous use
Protection class	IP44
Operating temperature	-20°C / +50°C
Noise	<70 dB
Lubrication	Grease
Weight	50,8 kg

3) ARC COMPATIBLE CONTROL UNIT

IMPORTANT, PLEASE READ CAREFULLY:

The radio receiver in this product is compatible with the new ARC (Advanced Rolling Code) transmitters which, thanks to 128-bit encryption ensure superior copy-security.

Storing new ARC transmitters is quite similar to that of normal rolling code transmitters with HCS coding, but be aware that:

1) ARC transmitters and Rolling Code HCS can not be stored in a single receiver.

2) The first transmitter memorized determines the type of transmitters to be used later. If the first transmitter memorized is ARC, you can not store Rolling code HCS transmitters, and vice versa.

3) Fixed code transmitters may only be used in conjunction with Rolling code HCS transmitters, bringing the logic CVAR OFF. They are, therefore, not usable in combination with the ARC transmitters. If the first rolling code transmitter stored is an ARC CVAR the logic is inoperative.

4) If you want to change the type of transmitters it is necessary to proceed with a receiver reset.

4) POSITIONING THE SPRING AND THE ACCESSORIES FOR USE

Depending on the length of the bar and on the type of accessories installed, before putting the spring under tension it is necessary to choose the correct point in which to attach the spring to the lever.

The correct fastening point ("A", "B" or "C" - Fig.2), must be chosen in table 1, depending on the length of the bar and on the type of accessories you intend to install.

LADY - TAB. 1	Bar length (m)				
	2,2	2,7	3,2	3,7	4,2
Accessories for use	2,2	2,7	3,2	3,7	4,2
NA	C	C	C	B	A
LADY.P(1)	C	C	B	B	A
LADY.P(2)	C	C	B	B	A
VE.RAST	C	B	B	A	
LADY.P(1) + VE.RAST	C	B	B	A	
LADY.P(1) + VE.AM	C	B	B	A	A
LADY.P(2) + VE.AM	C	B	B	A	
LADY.P(1) + VE.RAST + VE.AM	C	B	A		
SC.RES	C	B	B	A	
LADY.P (1) + SC.RES	C	B	A	A	
SC.RES + VE.AM	C	B	A	A	
LADY.P(1)+ SC.RES + VE.AM	C	B	A		

LADY 5 - TAB. 1	Bar length (m)			
	3,7	4,2	4,7	5,2
Accessories for use	3,7	4,2	4,7	5,2
NA			C	C
LADY.P(1)		C	B	B
LADY.P(2)	C	C	B	B
VE.RAST	C	B	B	A
LADY.P(1) + VE.RAST	C	B	A	A
LADY.P(1) + VE.AM	C	C	B	B
LADY.P(2) + VE.AM	C	B	B	A
LADY.P(1) + VE.RAST + VE.AM	B	B	A	A
SC.RES	C	B	B	A
LADY.P (1) + SC.RES	C	B	A	A
SC.RES + VE.AM	B	B	A	A
LADY.P(1)+ SC.RES + VE.AM	B	B	A	A
VE.RAST + VE.AM	B	B	A	A

Key

NA	No accessories
LADY.P(1)	Protection profile (only upper).
LADY.P(2)	Protection profiles (upper and lower).
VE.RAST	Aluminium skirt.
VE.AM	Mobile support for bar.
SC.RES	Sensitive resistive edge (complying EN12878).

Attention:

The installation of the VE.RAST interferes with the use of the SC.RES and vice versa.

The installation of the LADY.L lights kit does not influence the balancing of the bar

5) INSTALLATION OF THE OPTIONAL FOUNDATION PLATE VE.PS (FIG.3)

After preparing the cable laying (mains power supply, accessories, etc.), place the foundation plate keeping to dimensions indicated.

Brackets to be cemented are supplied with the system (ref. A). The brackets must be fitted to the foundation plate by means of nuts (B) and corresponding washers C.

Check that the foundation plate is perfectly flat (ref. F), then fix the road barrier by means of nuts D and corresponding washers E.

Notes: the special shape of the slots on the bottom of the barrier cabinet, allow to adjust finely the position of the barrier.

It is suggested to leave 30 mm of threaded bar out from the foundation plate, a bigger length could generate an interference with the spring, a smaller length does not ensure the proper fixing of the barrier.

6) FIXING THE BAR (FIG.4)

The bar is fixed to the plate using the support and the screws provided, as illustrated in Fig.4. We recommend installing any accessories for the bar (protective profiles, lights, edge, skirt, etc.) before fixing it to the plate.

7) PREPARING THE BARRIER FOR RIGHT OR LEFT (FIG.5)

If the opening direction reversion is required, proceed as follows. If it is not necessary, go to the next section:

- Entirely unload the spring by loosening it and unhooking it from the "L" anchoring lever
- unlock the geared motor (see "Manual Operation") insofar as to render the L hooking lever idle.

- according to the length of the road barrier arm and accessories used, choose the correct hooking position, as indicated in paragraph “Positioning of the spring and accessories”.
- hook the spring in the new position. Fig. 5 shows the differences between a right-hand road barrier and a left-hand one.

8) MANUAL AND EMERGENCY MANOEUVRES (FIG. 6)

In the event of a power cut or of abnormal operation, it is possible to release the bar and move it by hand (Fig. 6).

Using the key provided:

- To release the bar, turn the key in a clockwise direction until you feel a certain resistance.
- To restore the automatic movement of the bar, turn the key in an anti-clockwise direction until it is blocked.

9) BALANCING (FIG. 7)

For good operation of the barrier it is fundamental for the bar to be suitably balanced by the action of the spring. To check this, proceed as follows:

- Ensure that the spring is fixed to the correct point of the lever (see paragraph 2).
- Mechanically release the barrier using the release key.
- The correctly balanced bar must stay still in whichever point it is positioned:
 - if it tends to open, decrease the tension of the spring
 - if it tends to close, increase the tension of the spring

The tension of the spring may be regulated by manually screwing (anti-clockwise rotation) or unscrewing (clockwise rotation) the spring itself. Once you have regulated the spring tension, block it, screwing down the nut “D” until it makes contact with the cap T.

10) REGULATING THE MECHANICAL STOPS (FIG.8)

With reference to Fig.8:

- Slacken the blocking dowel G
- Tighten /unscrew the mechanical stop F until the desired position of intervention is obtained
- Tighten the blocking dowel G

11) WIRE DIAGRAM (FIG.11)

- 1 Control unit CP.LADY
- 2 Transmitting photocell FTC
- 3 Receiving photocell FTC
- 4 Blinking lights LADY.L
- 6 Bottom/top rubber protection LADY.P
- 7 Resistive edge SC.RES
- 8 Mod. VE.AF / VE.AFI accessory

12) CP.LADY CONTROL UNIT WIRE DIAGRAM

Wire connections shown in Fig. 12 are described hereunder:

SA.24V		
TERMINALS	Function	Description
L-N-GND	Power supply	Mains input 100÷250Vac 50/60Hz
+ -	Output 24Vdc	Controller CP.1524 power supply output 24 Vdc
+ BAT-BAT	Batteries	Clamp input for connection of back-up batteries (accessory).

CP.LADY		
TERMINAL BLOCK M1		
M1	24Vdc INPUT	24Vdc input for powering the CP.LADY. In case of use of the SUN SYSTEM it is necessary to connect the 24Vdc output of the SUN.SY to M1 (see the KSUN instructions)

TERMINAL BLOCK M2		
P.P.	Step by step	Input for step by step command (N.O. contact) .
CLOSE	Close	Input for close command (N.O. contact) .
OPEN	Open	Input for open command (N.O. contact), It is possible to connect a timer for programmed openings.
PHOT	Photocell	Input for photocells enabled during opening and closing phase (N.C. contact).
STOP	STOP	Input for STOP command (N.C. contact).
SWC	Closing limit switch	CLOSED limit switch input (NO contact)
SWO	Opening limit switch	OPEN limit switch input (NO contact)
COM	Common	Common for all the input commands and the limit switches .
AUX2	24Vdc output for bar light	24Vdc output for the bar flashing light LADY.L (max 2), the flashing mode can be set by means of the logic LBAR.
BLINK	Blinker	Output 24Vdc 15W max. for flashing light connection.

TERMINAL BLOCK M3		
ANT-SHIELD	Antenna	Connection for the antenna of the built in receiver (ANT-signal/SHIELD-shield). In case of use of an external antenna it is necessary to remove the pre-cabled cable from the terminal ANT
AUX	Auxiliary output AUX 1	Output with N.O. contact configurable by means of the logic AUX 1
24V	24 Vdc	Accessory power supply 24Vdc 500 mA maximum
MOT	Motor	Motor connection: 24Vdc.

13) PROGRAMMING

The programming of the various functions of the control unit is carried out using the LCD display on the control unit and setting the desired values in the programming menus described below.

The parameters menu allows you to assign a numerical value to a function, in the same way as a regulating trimmer.

The logic menu allows you to activate or deactivate a function, in the same way as setting a dip-switch.

13.1) TO ACCESS PROGRAMMING

- 1 -Press the <PG> button to enter the first Installation menu "INST".
- 2 -Choose with <+> or <-> button the menu you want to select
- 3 - Press the button <PG>, the display shows the first function available on the menu.
- 4 - With the <+> or <-> button, select the function you want.
- 5 - Press the button <PG>, the display shows the value currently set for the function selected.
- 6 - With the <+> or <-> button, select the value you intend to assign to the function.
- 7 - Press the button <PG>, the display shows the signal "PRG" which indicates that programming has been completed.

13.2) PROGRAMMING NOTES

Simultaneously pressing <+> and <-> from inside a function menu allows you to return to the previous menu without making any changes. Hold down the <+> key or the <-> key to accelerate the increase/decrease of the values.

Hold down the <+> key or the <-> key to accelerate the increase/decrease of the values.





After waiting 120s the control unit quits programming mode and switches off the display.

When the board is switched on, the software version is displayed for around 5 sec

The pre-set logic functions and parameters are made taking account of a typical installation.

14) PARAMETERS, LOGICS AND SPECIAL FUNCTIONS

The following tables describe the functions available on the control unit

14.1) INSTALLATION (<i>inst</i>)			
MENU	FUNCTION	MIN-MAX-(Default)	MEMO
<i>boom</i>	Select the length of the boom installed on the barrier. Value expressed in meter from 3m to 5m (all LADY/LADY 5 models) or from 7m to 8m (other models) According to the selected boom length, the optimal value of speed will be set.	3/5 -7/8 (7-8)	
<i>Pos</i>	Set the closing direction of the barrier. The symbol  indicates right barrier (R/RIGHT) DEFAULT The symbol  indicates left barrier (L/LEFT) Verify the opening direction of the boom and in case reverse it. Every change of this function automatically implies the starting of a new AUTOSET procedure.	 = RIGHT  = LEFT (RIGHT)	
<i>mode</i>	Select the use mode of the barrier. <i>norm</i> : Standard operating mode, for barriers used in a residential/industrial environment and with normal traffic. <i>Parc</i> : Park operating mode, for barriers used in parking systems. In this mode, to promote transit of a high number of vehicles, the control unit automatically sets a specific configuration which includes: 1) Rapid closure enabled (SCL:ON) with time reduced from 3 to 0 seconds. 2) Automatic closure enabled (TCA:ON) which with rapid closure enabled causes, during the opening phase, immediate closure of the barrier as soon as the PHOT input is free. 3) During the closure phase, PHOT entrance activation stops the barrier, as soon as the PHOT input is free again, the barrier starts the closure manoeuvre.	Norm - Parc (Norm)	

14.2) PARAMETERS (<i>PRr</i>)			
MENU	FUNCTION	MIN-MAX-(Default)	MEMO
<i>tcr</i>	Automatic closing time. Enabled only with logic "TCA"=ON. At the end of the set time, the control unit commands a closing maneuver .	1-240-(20s)	
<i>FstS</i>	Adjusts the opening and closing speed of the barrier (standard speed, before the slowdown phase).	50-99-(99)	
<i>SLdo</i>	Adjusts the slowdown speed of the barrier during the opening phase* (Fig.9 -slow Open).	20-70-(50)	
<i>SLdc</i>	Adjusts the slowdown speed of the barrier during the closing phase * (Fig.10 -slow Close).	20-70-(50)	
<i>tSnO</i>	Sets the starting point of the slowdown during the opening phase (Fig.9- beginning of the slow Open). The value is expressed in seconds.	1-99-(20)	
<i>tSnc</i>	Sets the starting point of the slowdown during the closing phase (Fig.10- beginning of the slow Close). The value is expressed in seconds.	1-99-(20)	
<i>Pno</i>	Adjusts the motor torque applied to the barrier during the opening phase.*	1-99-(20)	

<i>Pnc</i>	Adjusts the motor torque applied to the barrier during the closing phase.*	1-99-(20)	
<i>PSo</i>	Adjusts the motor torque applied to the barrier during the slowdown in opening phase *(Fig.9 - Slow Open).	1-99-(20)	
<i>PSc</i>	Adjusts the motor torque applied to the barrier during the slowdown in closing phase *(Fig.10- Slow Close).	1-99-(20)	
<i>SEAU</i>	Not used		
<i>SEAr</i>	Not used		
<i>tLS</i>	Activation time of the courtesy light contact. Value expressed in seconds. At the beginning of each maneuver the contact latches for the set time. See the description of AUX1 parameter.	1-240 (60)	
<i>SASo</i>	Sets a short reversion after reaching the limit switch in open position. Can be useful for facilitating the manual release.	0-5 (0)	
<i>SASc</i>	Sets a short reversion after reaching the limit switch in close position. Can be useful for facilitating the manual release.	0-5 (0)	
<i>AUX 1</i>	Selects the functioning mode of the auxiliary output 1 (N.O. clean contact) 0: Open barrier light, close contact when the barrier is open, open contact when the barrier is close, intermittent during the maneuver (fig. 15, SCA) 1: Second radio channel of the built in receiver 2: Boom light, for controlling the LED light installed on the BOOM (EVA.LED), see also the parameter LBAR. 3: Courtesy light, the contact remains close according to the parameter TLS (fig.15 SERVICE LIGHT) 4: Photocells test, see wiring diagram in Fig.15 (PHOTOTEST) 5: Close contact with open barrier 6: Close contact with close barrier 7: Maintenance warning light. The contact closes when the number of manoeuvres set in the Maintenance Cycle menu is reached (MACI).	0-6-(0)	
<i>AUX 2</i>	Selects the functioning mode of the auxiliary output 1 (N.O. clean contact) 0: Open barrier light, close contact when the barrier is open, open contact when the barrier is close, intermittent during the maneuver (fig. 15, SCA) 1: Second radio channel of the built in receiver 2: Boom light, for controlling the LED light installed on the BOOM (EVA.LED), see also the parameter LBAR. 3: Courtesy light, the contact remains close according to the parameter TLS (fig.15 SERVICE LIGHT) 4: Photocells test, see wiring diagram in Fig.15 (PHOTOTEST) 5: Close contact with open barrier 6: Close contact with close barrier 7: Maintenance warning light. The contact closes when the number of manoeuvres set in the Maintenance Cycle menu is reached (MACI).	0-6-(2)	

*** ATTENTION: A WRONG SETTING OF THESE PARAMETERS CAN BE DANGEROUS.
RESPECT THE REGULATION IN FORCE!**

14.3) LOGICS (LcL)

MENU	FUNZIONE	ON-OFF-(Default)	MEMO
<i>tcr</i>	Enables or disables automatic closing On: automatic closing enabled Off: automatic closing disabled	(ON)	
<i>ibL</i>	Enables or disables condominium function. On: condominium function enabled. The step-by-step impulse or transmitter impulse has no effect during the opening phase. Off: condominium function disabled.	(OFF)	
<i>ibcR</i>	The multi-flat function is enabled or disabled during the TCA counting. On: the bloc of flat function is enabled. The Step-by-Step signal or the transmitter signal has no effect during the TCA counting. Off: the bloc of flat function is disabled.	(OFF)	
<i>ScL</i>	Enables or disables rapid closing On: rapid closure is enabled. With open bar, or in the opening phase, the activation of the photocell causes the automatic closure 3sec after the total opening of the gate. It is activated only with TCA:ON Off: rapid closing disabled.	(OFF)	
<i>PP</i>	Selects the operating mode of the "Step by step button" and of the transmitter. On: Operation: OPEN > CLOSE > OPEN > Off: Operation: OPEN > STOP > CLOSE > STOP >	(OFF)	
<i>PrE</i>	Enables or disables pre-blinking. On: Pre-blinking enabled. Blinking is activated 3s before the motor starts. Off: Pre-blinking disabled.	(OFF)	
<i>htr</i>	Enabled or disables HOLD-TO-RUN function On: HOLD-TO-RUN function. The pressure of the OPENS/CLOSES button must be maintained throughout the entire manoeuvre. The opening of the STOP input stops the motor. All the safety inputs are deactivated. Off: Automatic/semiautomatic function	(OFF)	
<i>Ltcr</i>	Selects the operating mode of the blinking light during the time TCA On: Blinking light on during TCA Off: Blinking light off during TCA	(OFF)	

tSt1	Enables or disables checking of photocells on PHOT input, active both in closing and in opening. On: Check enabled. If the check has a negative result, no manoeuvre is commanded. See Fig.13 - "PHOTO TEST". Off: Checking of photocells disabled at each manoeuvre.	(OFF)	
tStn	Enables or disables motors check. On: Check enabled. If the check has a negative result, no manoeuvre is commanded. Off: Check disabled.	(OFF)	
cUAr	The code programmable transmitters is enabled or disabled. On: Radio receiver enabled only for rolling-code transmitters. Off: Receiver enabled for rolling-code and programmable code transmitters (self-learning and Dip Switch).	(ON)	
LbAr	Selects the functioning mode of the boom light (24Vdc output on AUX2 or N.O. contact on the output AUX 1 when configured at 2). On: The boom light is off when the barrier is close, it turns on when the barrier is in movement or open. On: The boom light flashes slowly when the barrier is close (1s pause), it flashes quickly (0,5s pause) when the barrier is in movement or open.	(OFF)	
RdPF	The "forced opening in case of power cut-off" function is activated or deactivated (it can be activated only with connected and operating emergency batteries). On: Activated function. In the event of power failure, the control unit causes an opening operation. The barrier remains open until the power supply is back. Off: Deactivated function.	(OFF)	
rEn	Enables or disables remote radiotransmitters learning, as indicated in the paragraph "Remote transmitters learning". On: Remote learning enabled. Off: Remote learning not enabled.	(OFF)	

14.4) RADIO (rPd t)

MENU	FUNZIONE
pp	By selecting this function, the receiver goes in waiting (PUSH) for a transmitter code to assign to the step-step function. Press the key of the transmitter to assign to this function. If the code is valid, it is memorised and the message oH is displayed If the code is not valid, the message Err is displayed
oPEn	By selecting this function, the receiver goes in waiting (PUSH) for a transmitter code to assign to the OPEN function. Press the key of the transmitter to assign to this function. If the code is valid, it is memorised and the message oH is displayed If the code is not valid, the message Err is displayed
cLoSE	By selecting this function, the receiver goes in waiting (PUSH) for a transmitter code to assign to the CLOSE function. Press the key of the transmitter to assign to this function. If the code is valid, it is memorised and the message oH is displayed If the code is not valid, the message Err is displayed
2ch	By selecting this function, the receiver goes into waiting (PUSH) for a transmitter code to assign to the second radio channel. Press the key of the transmitter to assign to this function. If the code is valid, it is memorised ad the oH message is displayed If the code is not valid, the message Err is displayed.
nEH	By selecting this function the LCD screen shows the number of transmitters memorized into the receiver.
cLr	By selecting this function, the receiver goes into waiting (PUSH) for a transmitter code to erase from the memory. If the code is valid, it is erased and the message oH is displayed If the code is not valid or not present in memory, the message Err is displayed
rEr	Completely erases memory of the receiver. Confirmation of the operation is requested. By selecting this function the receiver goes into waiting (PUSH) for a new PGM pressure to confirm the operation. At end of erasing the oH message is displayed

14.5) CYCLES NUMBER (nAn)

Displays the number of complete cycles (open+close) carried out by the automation.

When the <PG> button is pressed for the first time, it displays the first 4 figures, the second time it shows the last 4. Example <PG> 00 12 >>> <PG> 3456: made 123.456 cycles.

14.6) MAINTENANCE CYCLES (nAc t)

This function enables to activate the maintenance request notice after a number of manoeuvres determined by the installer.

To activate and select the number of manoeuvres, proceed as follows:

Press button <PG>, the display will show OFF, which indicated that the function is disabled (default value).

With the buttons <+> and <-> select one of the numeric values proposed (from OFF to 100). The values are intended as hundreds of cycles of manoeuvres (for example: the value 50 indicates 5000 manoeuvres).

Press the OK button to activate the function. The display will show the message Pr oG.

The maintenance request is indicated to the user by keeping the indicator lamp lit up for other 10 sec after the conclusion of the opening or closing operation.

14.7) RESET (rE5)

RESET of the control unit. ATTENTION!: Returns the control unit to the default values.

Pressing the <PG> button for the first time causes blinking of the letters rE5, pressing the <PG> button again resets the control unit. Note: The transmitters are not erased from the receiver nor is the access password.

All the logics and all the parameters are brought back to default values, it is therefore necessary to repeat the autose procedure.

14.8) AUTOSET (ββτα)

This function sets the optimal functioning values of the installation, at the end of the procedure, it sets the average values of torque (PMO/PMC and PSO/PSC).

To carry out the AUTOSET, proceed as follow:

a) Make sure that during the autose there is no obstacle in the maneuver area, if necessary, fence off the area so that persons, animals, cars, etc., cannot interrupt the procedure.

During the AUTOSET procedure, the anti crushing feature is not enabled.

b) select the function AUTO and press PG.

c) the control unit waits the confirmation to start the procedure "PUSH"

d) press PG to start the AUTOSET procedure.

The control unit performs few maneuvers for the stroke learning and the configuration of the parameters.

In case that the procedure is not successful the message ERR will be shown. Repeat the procedure after checking the wirings and the possible presence of obstacles.

14.9) PASSWORD (codE)

It allows to type in an access protection code to the programming of the control unit.

A four-character alphanumeric code can be typed in by using the numbers from 0 to 9 and the letters A-B-C-D-E-F.

The default value is 0000 (four zeros) and shows the absence of a protection code.

While typing in the code, this operation can be cancelled at any moment by pressing keys + and - simultaneously. Once the password is typed in, it is possible to act on the control unit by entering and exiting the programming mode for around 10 minutes in order to allow adjustments and tests on functions.

By replacing the 0000 code with any other code, the protection of the control unit is enabled, thus preventing the access to any other menu. If a protection code is to be typed in, proceed as follows:

- select the Code menu and press OK.

- the code 0000 is shown, also in the case a protection code has been previously typed in.

- the value of the flashing character can be changed with keys + and -.

- press OK to confirm the flashing character, then confirm the following one.

- after typing in the 4 characters, a confirmation message "CONF" appears.

- after a few seconds, the code 0000 appears again

- the previously stored protection code must be reconfirmed in order to avoid any accidental typing in.

If the code corresponds to the previous one, a confirmation message "oH" appears.

The control unit automatically exits the programming phase. To gain access to the Menus again, the stored protection code must be typed in.

IMPORTANT: TAKE NOTE of the protection code and KEEP IT IN A SAFE PLACE for future maintenance operations.

To remove a code from a protected control unit it is necessary to enter into programming with the password and bring the code back to the 0000 default value.

IF YOU LOOSE THE CODE, PLEASE CONTACT THE AUTHORISED SERVICE CENTER FOR THE TOTAL RESET OF THE CONTROL UNIT.

14.10) SYNCHRONIZATION (ββ5)

MENU	FUNZIONE
Id	Sets the synchronizing number. It is possible to set a numeric value from 0 to 16. If the ID parameter is to 0 the control unit is set as MASTER, all the other values set the barrier as SLAVE.
Loc	Allows a barrier set as SLAVE to receive local commands. See paragraph 12.4 "SYNCHRONIZATION OF TWO OPPOSED BARRIERS"

15) SYNCHRONIZATION OF TWO OPPOSED BARRIERS

It is possible to manage a system composed of two barriers by using for each CP.LADY the specific optional control unit SIS, which must be plugged into the appropriate connector as shown in Fig. 12.

Each SIS unit must be connected to the other one by means of 3 wires by 0,5 sq.mm each, as shown in Fig.12.

One of the control unit must be set as MASTER (ID=0) and the other one as SLAVE (ID>0).

All the commands (commands given by transmitters, push buttons or safety devices) received by the MASTER barrier are sent to the SLAVE barrier, which will replicate instantaneously the behavior of the MASTER.

The logic LOC can be set in two ways:

ON: the SLAVE barrier can accept a local command and execute an opening/closing maneuver with no effect on the MASTER barrier.

OFF: the SLAVE barrier do not accept any local command and so it will replicate exclusively the behavior of the MASTER barrier.

A SLAVE barrier with LOC set to ON can be useful in case it is occasionally necessary the partial opening of a passage which is usually managed by two synchronized barriers, since that a step by step command (or OPEN/CLOSE) given to the SLAVE will have effect only on this last one, while all the other commands given to the MASTER will be replicated by the SLAVE.

The connection of the safety devices (photocells, safety edges, etc.) can be done indifferently to the MASTER unit or to the SLAVE.

16) TRANSMITTERS REMOTE LEARNING

If an already memorised transmitter is available in the receiver it is possible to carry out remote radio learning (without needing to access the control unit).

IMPORTANT: the procedure must be carried out with barrier open. The logic REM must be ON.

Proceed as follows:

1 Press the hidden key of the transmitter which is already memorised.

2 Press, within 5s, the key of the corresponding transmitter which is already memorised to associate to the new transmitter. The flashing light will turn on.

3 Press within 10s the hidden key of the new transmitter.

4 Press, within 5s, the key of the new transmitter to associate to the channel chosen at point 2. The flashing light will turn off.

5 The receiver memorised the new transmitter and immediately exits from programming.

17) FUSES

F3 CP.LADY: T1A - Fuse for the protection of the accessories power supply
 F1 SA.24V: T4A - Fuse for general protection

18) BACK UP BATTERIES

The control unit CP.LADY includes the power pack SA.24V predisposed for the connection of two batteries by 12Vdc 2,1Ah DA.BT2 (optional) which guarantee the regular functioning of the automation in case of temporary power failure.

When the barrier is working with mains voltage the power pack SA.24V charges the batteries (Fig. 12).

The maximum charging current is 1A, the average charging current is 300 mA.

19) DIAGNOSTICS

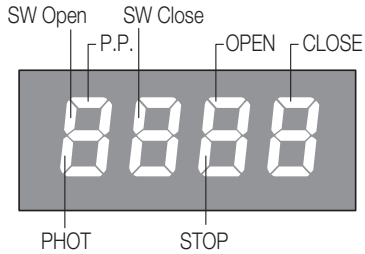

LED 1 : Presence of mains voltage

LED 2 : Control unit CP.LADY correctly powered

To each input is associated a line of the LCD screen which in case of activation it turns on according to the following diagram.

The N.C. inputs are represented by vertical lines.

The N.O. inputs are represented by horizontal lines.

The flashing mode of the lines SW Open (when the barrier is open) and SW Close (when the barrier is close)

20) ERROR MESSAGES

Some messages that are displayed in case of function anomalies are listed as follows:

<i>Err</i>	Generic error	Error inserting password or memorizing transmitter..
<i>Err 1</i>	Motor error	Verify the motor wirings, faulty motor or not connected, problem on the control unit.
<i>Err 2</i>	Photocells error	Verify connections, photocells alignment and presence of obstacles.
<i>Err 3</i>	Absolute encoder error	Verify encoder connections, verify the good functioning of the Encoder.
<i>ANP</i>	Amperometric sensor intervention	Verify the presence of obstacles or friction points.
<i>Thrn</i>	Thermal sensor intervention	Overheating due to a too intensive use, wait the restoring.
<i>oULd</i>	Overload	Exceeding of the maximum power. Verify the motor and presence of friction points..
<i>Enc</i>	Encoder	Encoder threshold intervention.

Norme di sicurezza

- Non sostare nella zona di movimento delle ante.
- Non lasciare che i bambini giochino con i comandi o in prossimità delle ante.
- In caso di anomalie di funzionamento non tentare di riparare il guasto ma avvertire un tecnico specializzato.

Manovra manuale di emergenza

In caso di assenza di alimentazione di rete o di funzionamento anomalo, è possibile sbloccare l'asta e manovrarla manualmente.

Utilizzando la chiave fornita in dotazione:

- Girare la chiave in senso orario fino ad avvertire una certa resistenza per sbloccare l'asta.
- Girare la chiave in senso antiorario fino al blocco per ripristinare il movimento automatico dell'asta.

Manutenzione

- Controllare periodicamente l'efficienza dello sblocco manuale di emergenza.
- Astenersi assolutamente dal tentativo di effettuare riparazioni, potreste incorrere in incidenti; per queste operazioni contattare un tecnico specializzato.
- L'attuatore non richiede manutenzioni ordinarie, tuttavia è necessario verificare periodicamente l'efficienza dei dispositivi di sicurezza e le altre parti dell'impianto che potrebbero creare pericoli in seguito ad usura.

Smaltimento

Qualora il prodotto venga posto fuori servizio, è necessario seguire le disposizioni legislative in vigore al momento per quanto riguarda lo smaltimento differenziato ed il riciclaggio dei vari componenti (metalli, plastiche, cavi elettrici, ecc.); è consigliabile contattare il vostro installatore o una ditta specializzata ed abilitata allo scopo.

Safety rules

- Do not stand in the movement area of the gate.
- Do not let children play with controls and near the gate.
- Should operating faults occur, do not attempt to repair the fault but call a qualified technician.

Manual and emergency manoeuvres

In the event of a power cut or of abnormal operation, it is possible to release the bar and move it by hand.

Using the key provided:

- To release the bar, turn the key in a clockwise direction until you feel a certain resistance.
- To restore the automatic movement of the bar, turn the key in an anti-clockwise direction until it is blocked.

Maintenance

- Every month check the good operation of the emergency manual release.
- It is mandatory not to carry out extraordinary maintenance or repairs as accidents may be caused. These operations must be carried out by qualified personnel only.
- The operator is maintenance free but it is necessary to check periodically if the safety devices and the other components of the automation system work properly. Wear and tear of some components could cause dangers.

Waste disposal

If the product must be dismantled, it must be disposed according to regulations in force regarding the differentiated waste disposal and the recycling of components (metals, plastics, electric cables, etc.). For this operation it is advisable to call your installer or a specialised company.

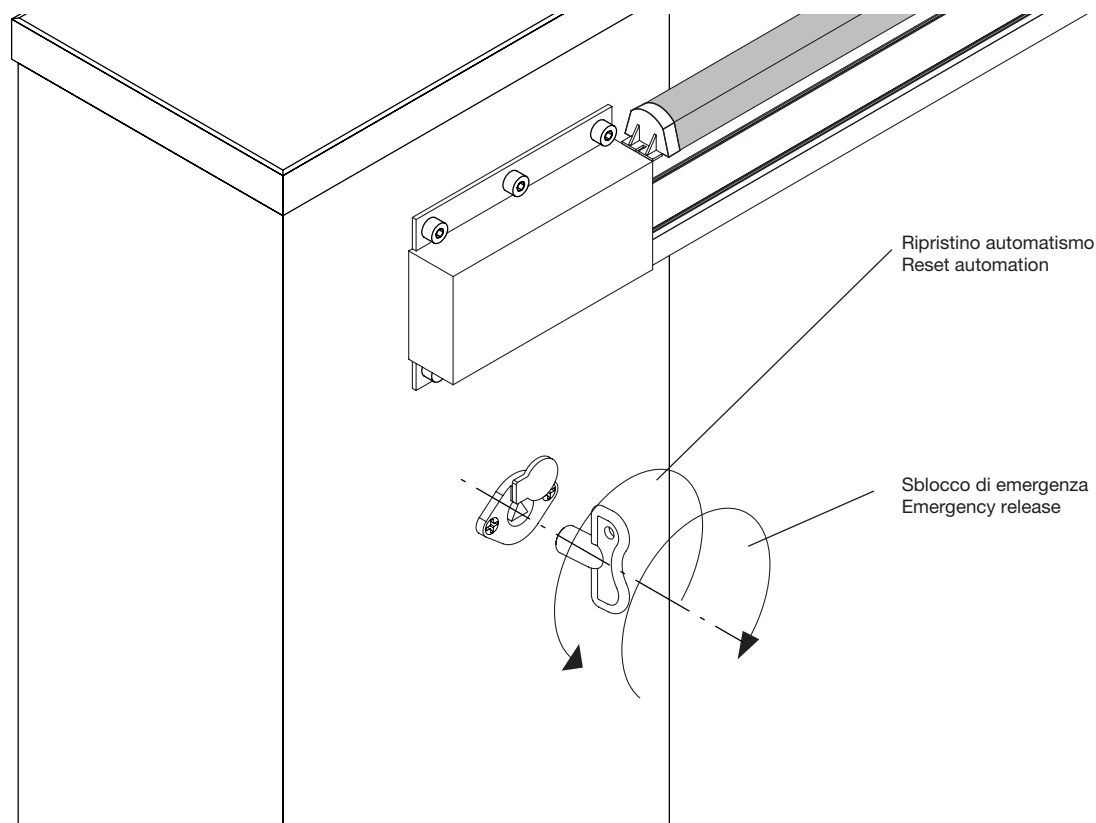

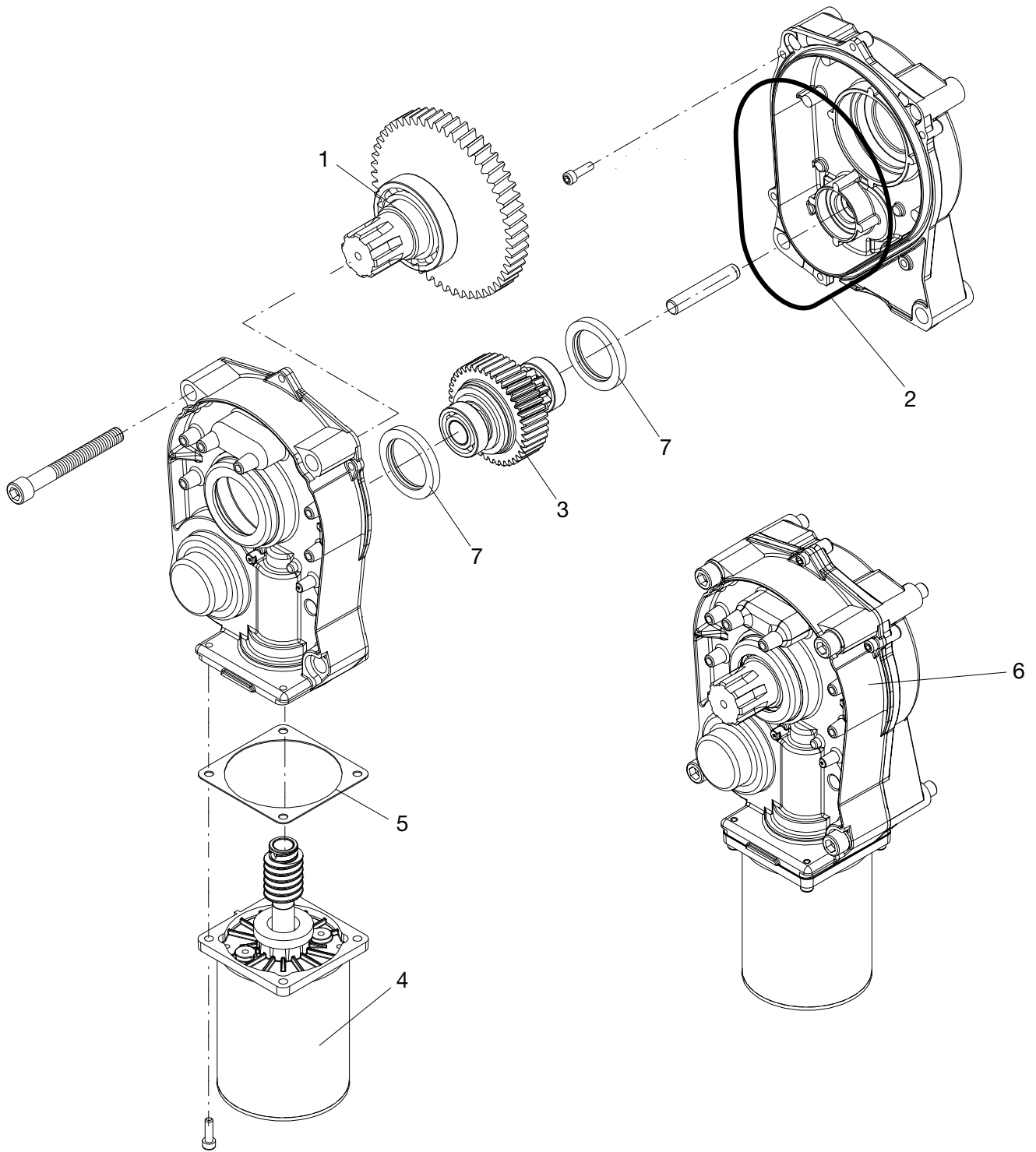

Ref.	LADY/LADY 5 Code	Note
1	9686110	
2	968601519	
3	968601520	
4	9686107	
5	9686109	
6	968601522	
7	9686555	

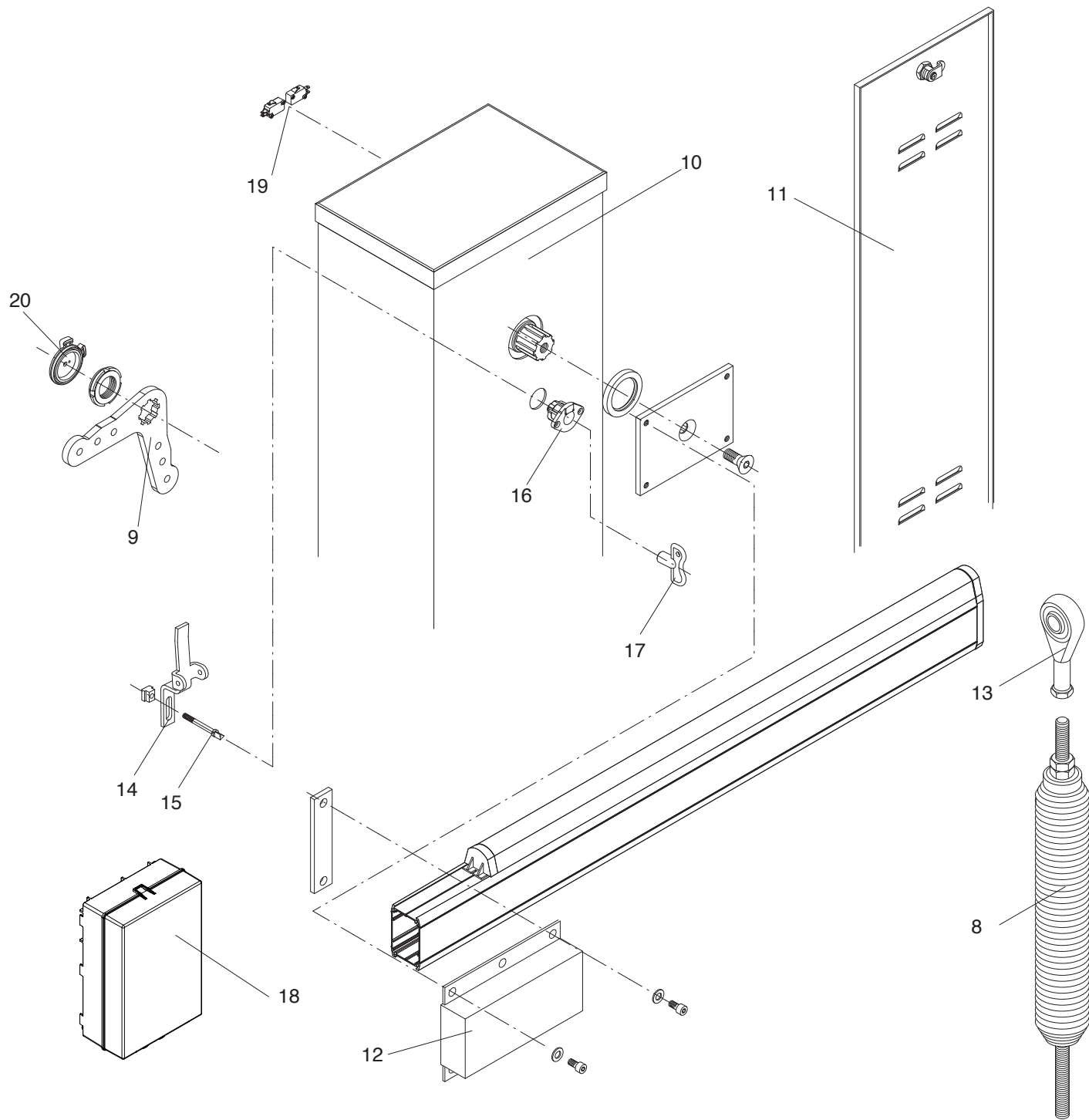

Ref.	LADY Code	LADY 5 Code	Note
8	9686183	968600647	
9	9686248	9686248	
10	968600915	968600915	
11	9686181	9686181	
12	6986184	6986184	
13	9686666	9686666	
14	9686190	9686190	
15	9686191	9686191	
16	9686192	9686192	
17	9686193	9686193	
18	968601410	968601410	CP.LADY
19	968601547	968601547	nr. 2 microsw..
20	9686160	9686160	

EU Certificato di Conformità (DOC)

Nome del produttore: Automatismi Benincà SpA
Indirizzo: Via Capitello, 45
Codice postale e Città: 36066 - Sandrigo (VI) - Italia
Telefono: +39 0444 751030
E-mail: sales@beninca.it

Dichiara che il documento è rilasciato sotto la propria responsabilità e appartiene al seguente prodotto:

Modello/Tipo: LADY / LADY5
Tipo di prodotto: Attuatore elettromeccanico 24Vdc per barriere stradali

Il prodotto sopraindicato risulta conforme alle disposizioni imposte dalle seguenti direttive:

Direttiva 2014/53/EU
Direttiva 2011/65/EU
Direttiva 2006/42/CE

Sono state applicate le norme armonizzate e le specifiche tecniche descritte di seguito:

ETSI EN 300 220-1 V3.1.1
ETSI EN 300 220-2 V3.1.1
ETSI EN 301 489-1 V2.1.1
ETSI EN 301 489-3 V2.1.1
EN 60950-1:2006 + A11:2009 + A1:2010 + A12:2011 + AC:2011 + A2:2013
EN 61000-6-2:2005, EN 61000-6-3:2007 + A1:2011
EN 60335-1:2012 + A11:2014, EN 60335-2-103:2015
50581:2012
EN 13241-1:2003
EN 12445:2002, EN 12453:2002, EN 12978:2003 (se applicabile)

Organismo notificato (se applicabile):

Ulteriori informazioni:

Firmato per conto di:
Sandrigo, 22/07/2020

Luigi Benincà, Responsabile legale

EU Declaration of Conformity (DOC)

Manufacturer's name: Automatismi Benincà SpA
Postal Address: Via Capitello, 45
Post code and City: 36066 - Sandrigo (VI) - Italia
Telephone number: +39 0444 751030
E-mail address: sales@beninca.it

Declare that the DOC is issued under our sole responsibility and belongs to the following product:

Model/Product: LADY / LADY5
Type: Electromechanical actuator 24Vdc for road barriers

The object of the declaration described above is in conformity with the relevant Union harmonization legislation:

Direttiva 2014/53/EU
Direttiva 2011/65/EU
Direttiva 2006/42/CE

The following harmonized standards and technical specifications have been applied:

ETSI EN 300 220-1 V3.1.1
ETSI EN 300 220-2 V3.1.1
ETSI EN 301 489-1 V2.1.1
ETSI EN 301 489-3 V2.1.1
EN 60950-1:2006 + A11:2009 + A1:2010 + A12:2011 + AC:2011 + A2:2013
EN 61000-6-2:2005, EN 61000-6-3:2007 + A1:2011
EN 60335-1:2012 + A11:2014, EN 60335-2-103:2015
50581:2012
EN 13241-1:2003
EN 12445:2002, EN 12453:2002, EN 12978:2003 (as applicable)

Notified body (where applicable):

Additional information:

Signed for and on behalf of:
Sandrigo, 22/07/2020

Luigi Benincà, Responsabile legale

EG-Konformitätserklärung (DOC)

Name des Herstellers: Automatismi Benincà SpA
Adresse: Via Capitello, 45
Codice postale e Città: 36066 - Sandrigo (VI) - Italia
Telefon: +39 0444 751030
E-mail: sales@beninca.it

Erklärt, dass das Dokument unter alleiniger Verantwortung herausgegeben wurde und zu dem folgenden Produkt ge-hört:MM

Modell/Produkt: LADY / LADY5
Type: Elektromechanischer 24Vdc-Antrieb für Straßenschranken

Das oben genannte Produkt stimmt mit den Vorschriften der folgenden Richtlinien überein:

Richtlinie 2014/53/EU
Richtlinie 2011/65/EU
Richtlinie 2006/42/CE

Die harmonisierten Normen und technischen Spezifikationen, die unten beschrieben werden, wurden angewandt:

ETSI EN 300 220-1 V3.1.1
ETSI EN 300 220-2 V3.1.1
ETSI EN 301 489-1 V2.1.1
ETSI EN 301 489-3 V2.1.1
EN 60950-1:2006 + A11:2009 + A1:2010 + A12:2011 + AC:2011 + A2:2013
EN 61000-6-2:2005, EN 61000-6-3:2007 + A1:2011
EN 60335-1:2012 + A11:2014, EN 60335-2-103:2015
50581:2012
EN 13241-1:2003
EN 12445:2002, EN 12453:2002, EN 12978:2003(falls anwendbar)

Benannte Stelle (falls zutreffend):

Weitere Informationen:

Unterzeichnet für und im Auftrag von:
Sandrigo, 22/07/2020

Luigi Benincà, Responsabile legale

Déclaration CE de conformité (DOC)

Nom du producteur : Automatismi Benincà SpA
Adresse: Via Capitello, 45
Ville et code postal: 36066 - Sandrigo (VI) - Italia
Téléphone: +39 0444 751030
E-mail: sales@beninca.it

Nous déclarons que le document est délivré sous notre propre responsabilité et qu'il appartient au produit suivant:

Modèle/Type: LADY / LADY5
Type de produit: Actionneur électromécanique 24Vdc pour barrières routières

Le produit mentionné ci-dessus est conforme aux dispositions établies par les directives suivantes:

Direttiva 2014/53/EU
Direttiva 2011/65/EU
Direttiva 2006/42/CE

Les normes harmonisées et les spécifications techniques décrites ci-dessous ont été appliquées:

ETSI EN 300 220-1 V3.1.1
ETSI EN 300 220-2 V3.1.1
ETSI EN 301 489-1 V2.1.1
ETSI EN 301 489-3 V2.1.1
EN 60950-1:2006 + A11:2009 + A1:2010 + A12:2011 + AC:2011 + A2:2013
EN 61000-6-2:2005, EN 61000-6-3:2007 + A1:2011
EN 60335-1:2012 + A11:2014, EN 60335-2-103:2015
50581:2012
EN 13241-1:2003
EN 12445:2002, EN 12453:2002, EN 12978:2003 (si applicable)

Organisme notifié (le cas échéant):

Plus d'informations:

Signé pour et au nom de:
Sandrigo, 22/07/2020

Luigi Benincà, Responsabile legale

Declaración CE de conformidad (DOC)

Nombre del productor: Automatismi Benincà SpA
Dirección: Via Capitello, 45
Ciudad y código postal: 36066 - Sandrigo (VI) - Italia
Teléfono: +39 0444 751030
E-mail: sales@beninca.it

Declaro que el documento ha sido emitido bajo la propia responsabilidad y pertenece al siguiente producto:

Modelo/Tipo: LADY / LADY5

Tipo de producto: Motorreductor electromecánico 24Vdc para barreras viales



El producto indicado arriba cumple con las disposiciones establecidas por las siguientes directivas:

Directiva 2014/53/EU
Directiva 2011/65/EU
Directiva 2006/42/CE

Han sido aplicadas las normas armonizadas y las especificaciones técnicas que se describen a continuación:

ETSI EN 300 220-1 V3.1.1
ETSI EN 300 220-2 V3.1.1
ETSI EN 301 489-1 V2.1.1
ETSI EN 301 489-3 V2.1.1
EN 60950-1:2006 + A11:2009 + A1:2010 + A12:2011 + AC:2011 + A2:2013
EN 61000-6-2:2005, EN 61000-6-3:2007 + A1:2011
EN 60335-1:2012 + A11:2014; EN 60335-2-103:2015
50581:2012
EN 13241-1:2003
EN 12445:2002, EN 12453:2002, EN 12978:2003 (si es aplicable)

Organismo notificado (en su caso):

Más información:

Firmado en nombre de:
Sandrigo, 22/07/2020

Luigi Benincà, Responsabile legale

Deklaracja zgodności CE (DOC)

Nazwa producenta: Automatismi Benincà SpA
Adres: Via Capitello, 45
Kod pocztowy i miasto: 36066 - Sandrigo (VI) - Italia
Teléfono: +39 0444 751030
Adres e-mail: sales@beninca.it

Oświadczam, że dokument został wydany na własną odpowiedzialność i dotyczy produktu:

Model/Typ: LADY / LADY5

Rodzaj produktu: Automatyzm 24Vdc do szlabanów drogowych



Wyżej wskazany produkt spełnia wymagania dyrektyw:

Dyrektywy 2014/53/EU
Dyrektywy 2011/65/EU
Dyrektywy 2006/42/CE

Uwzględniono normy zharmonizowane i zastosowano niżej wskazane specyfikacje techniczne:

ETSI EN 300 220-1 V3.1.1
ETSI EN 300 220-2 V3.1.1
ETSI EN 301 489-1 V2.1.1
ETSI EN 301 489-3 V2.1.1
EN 60950-1:2006 + A11:2009 + A1:2010 + A12:2011 + AC:2011 + A2:2013
EN 61000-6-2:2005, EN 61000-6-3:2007 + A1:2011
EN 60335-1:2012 + A11:2014; EN 60335-2-103:2015
50581:2012
EN 13241-1:2003
EN 12445:2002, EN 12453:2002, EN 12978:2003 (jeśli ma zastosowanie)

Jednostka notyfikowana (stosownych przypadkach):

Dodatkowe informacje:

Podpisano w imieniu:
Sandrigo, 22/07/2020

Luigi Benincà, Responsabile legale

BENINCA[®]

AUTOMATISMI BENINCÀ SpA - Via Capitello, 45 - 36066 Sandrigo (VI) - Tel. 0444 751030 r.a. - Fax 0444 759728
