

BULL 424SE - BULL 424SE.S BULL 624SE - BULL 624SE.S BULL 1024SE - BULL 1024SE.S

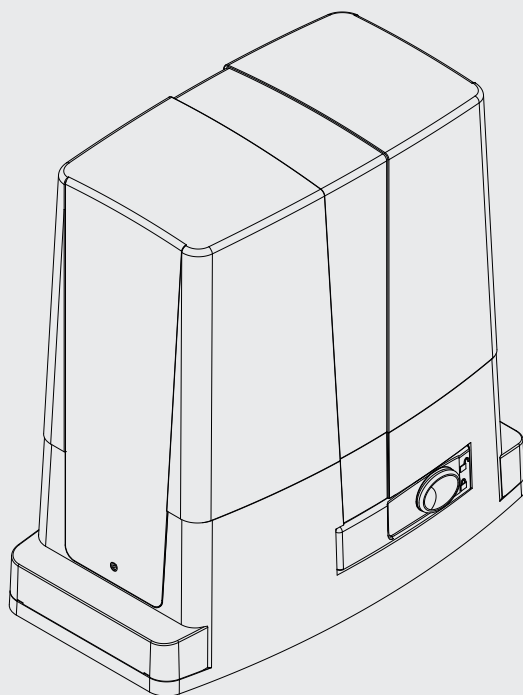

Manuale di installazione, uso e manutenzione
Installation, User and Maintenance Manual
Handbuch für Installation, Betrieb und Wartung
Manuel d'installation, d'utilisation et d'entretien
Manual de instalación, uso y mantenimient
Instrukcja instalacji, obsługi i konserwacji o

BENINCA[®]
TECHNOLOGY TO OPEN

1

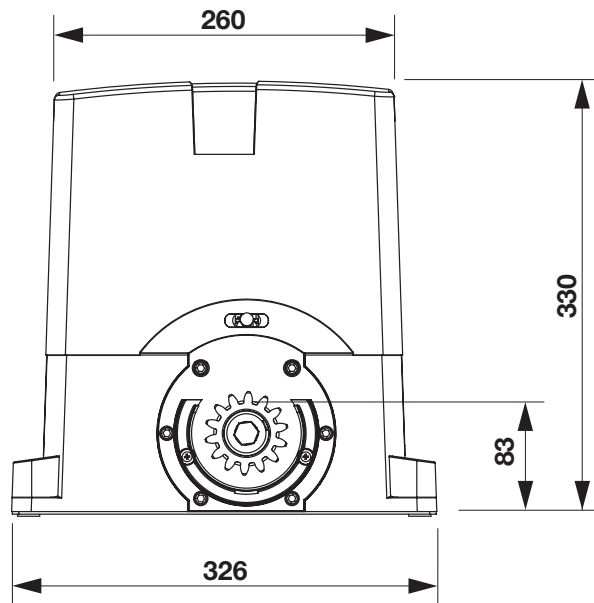
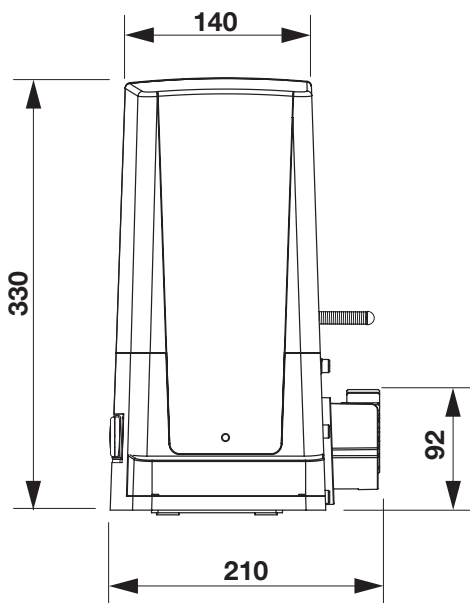

2

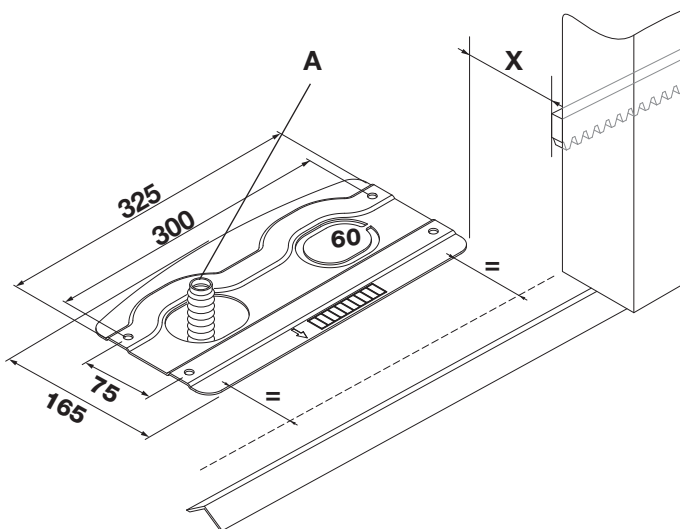

3

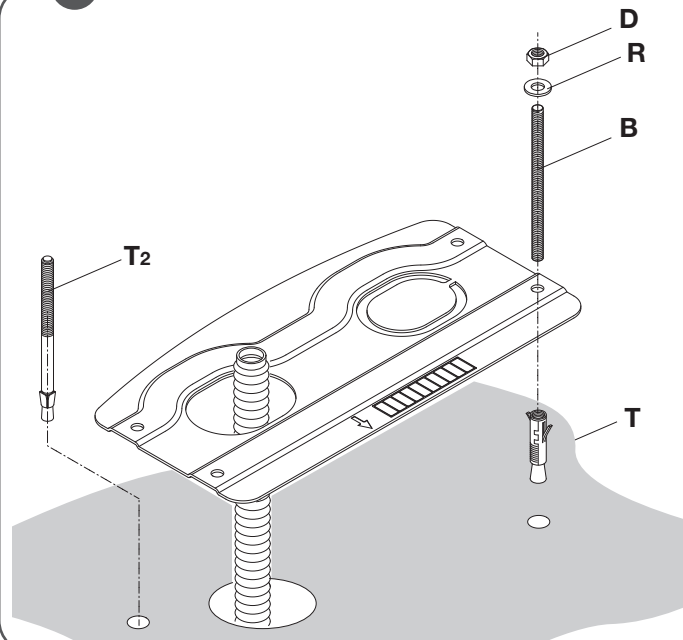

4

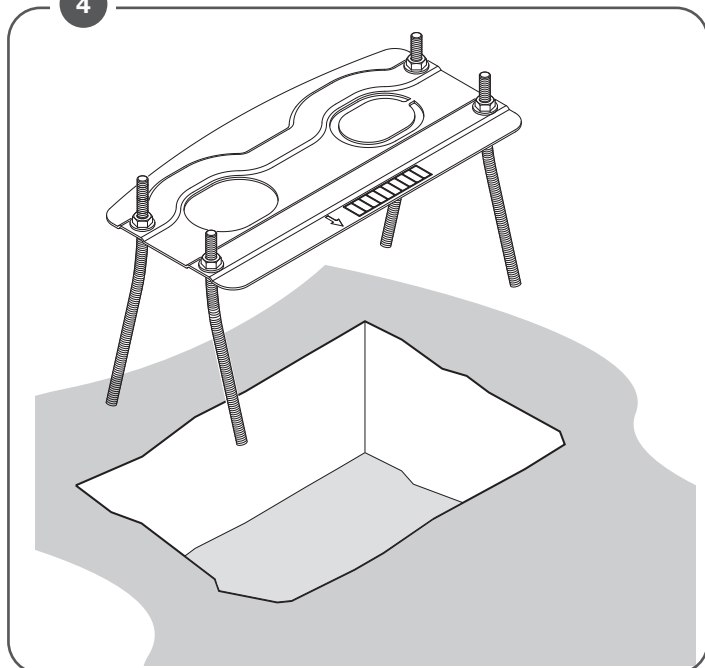

5

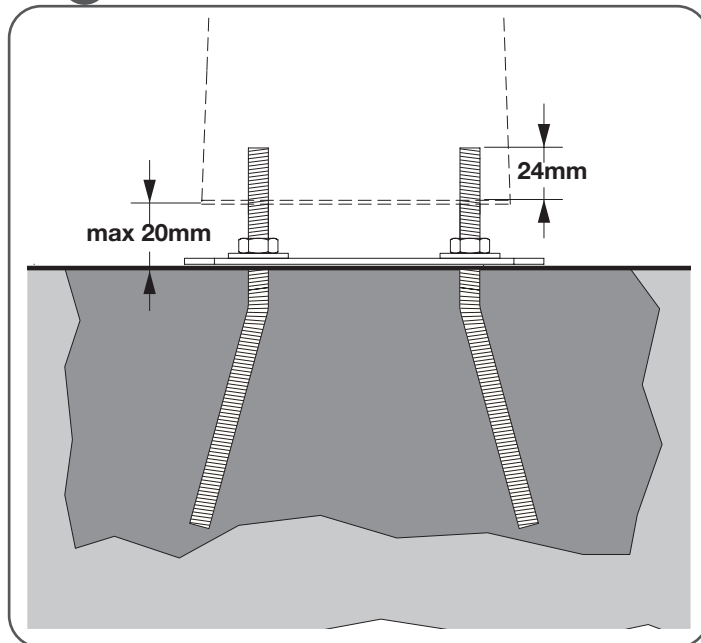

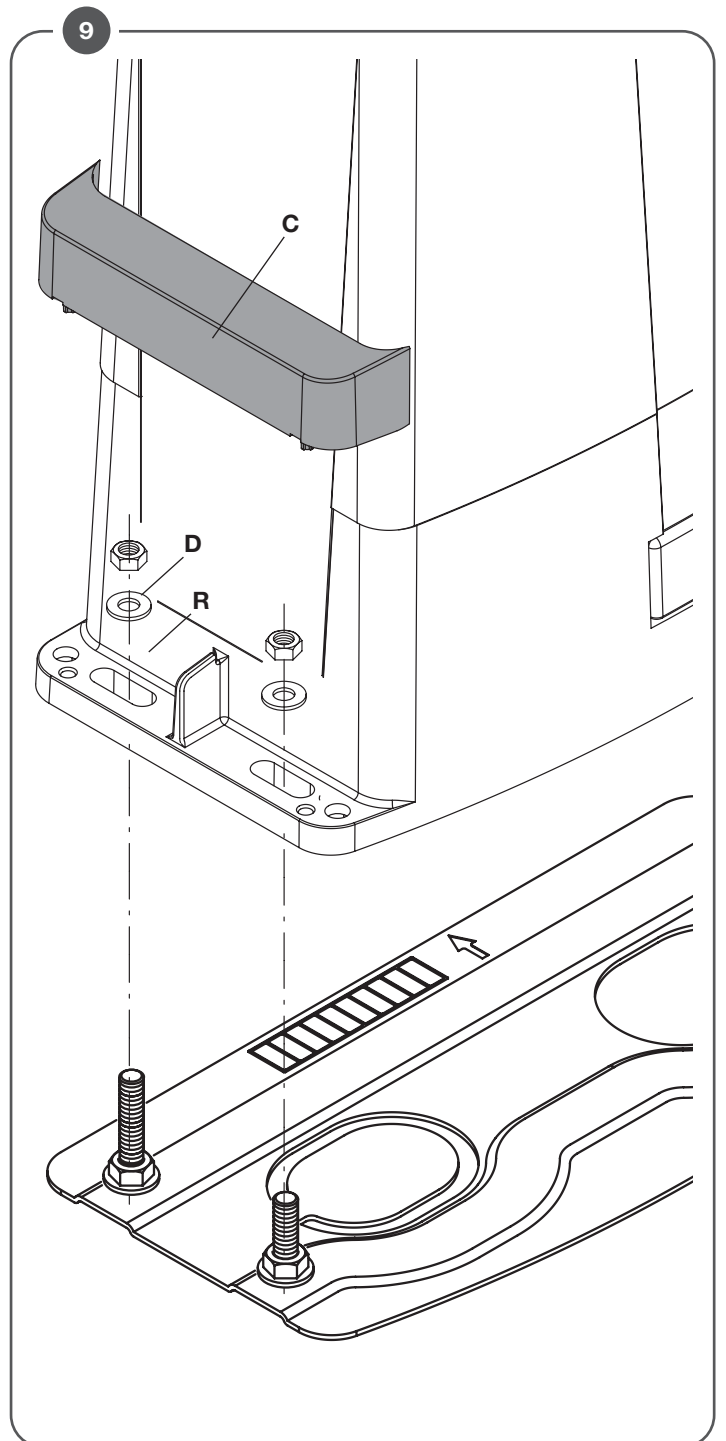
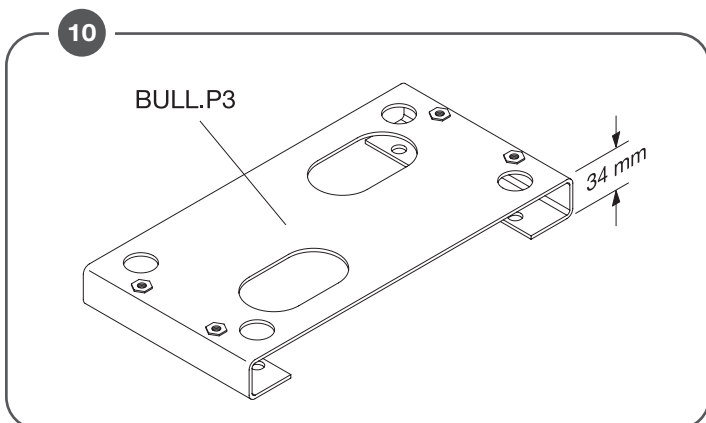
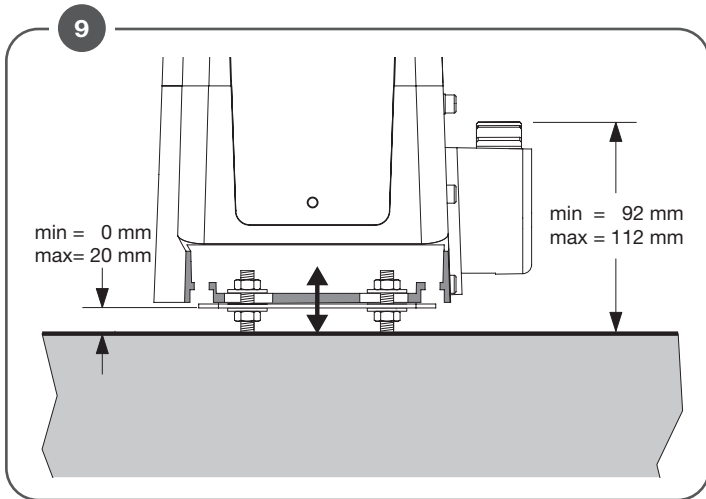
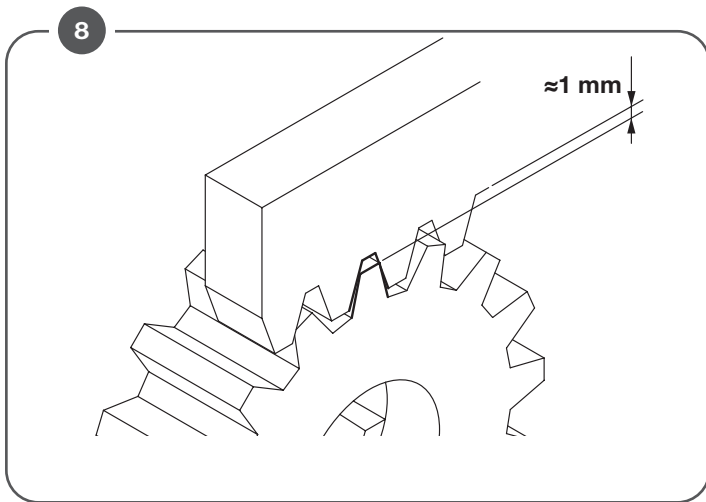
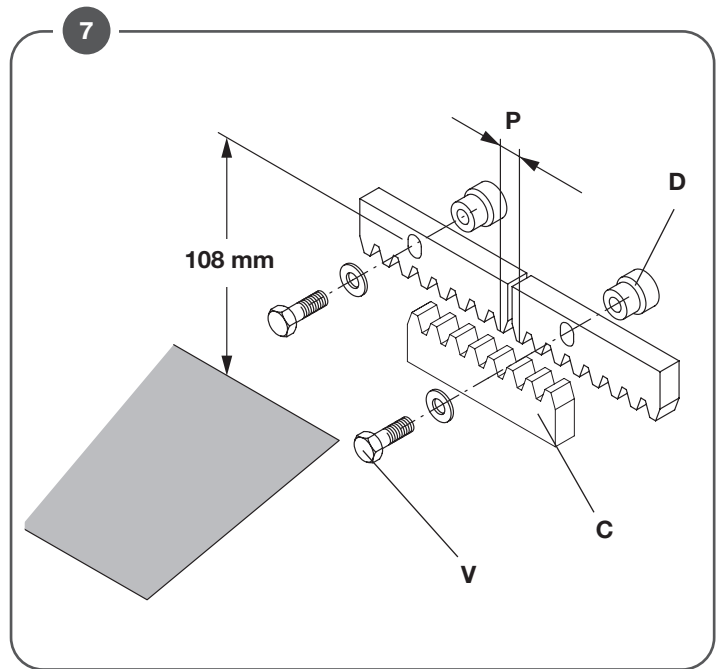
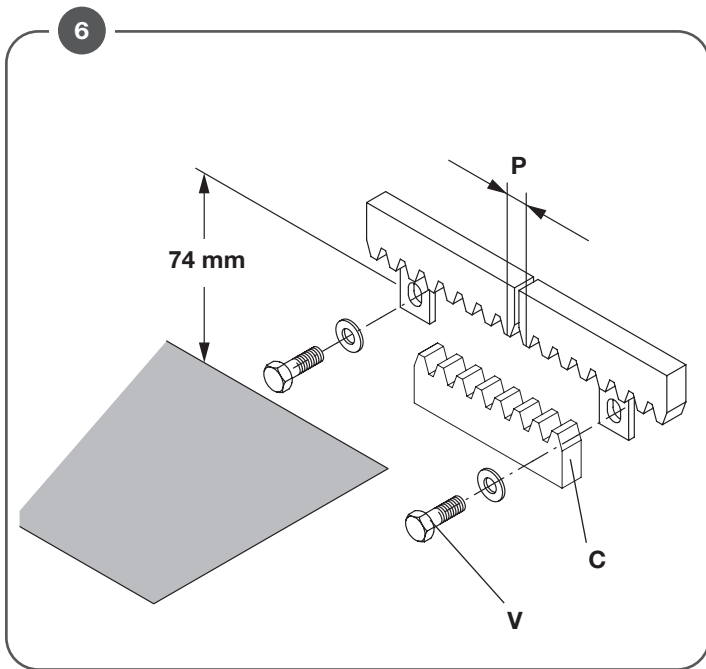

12

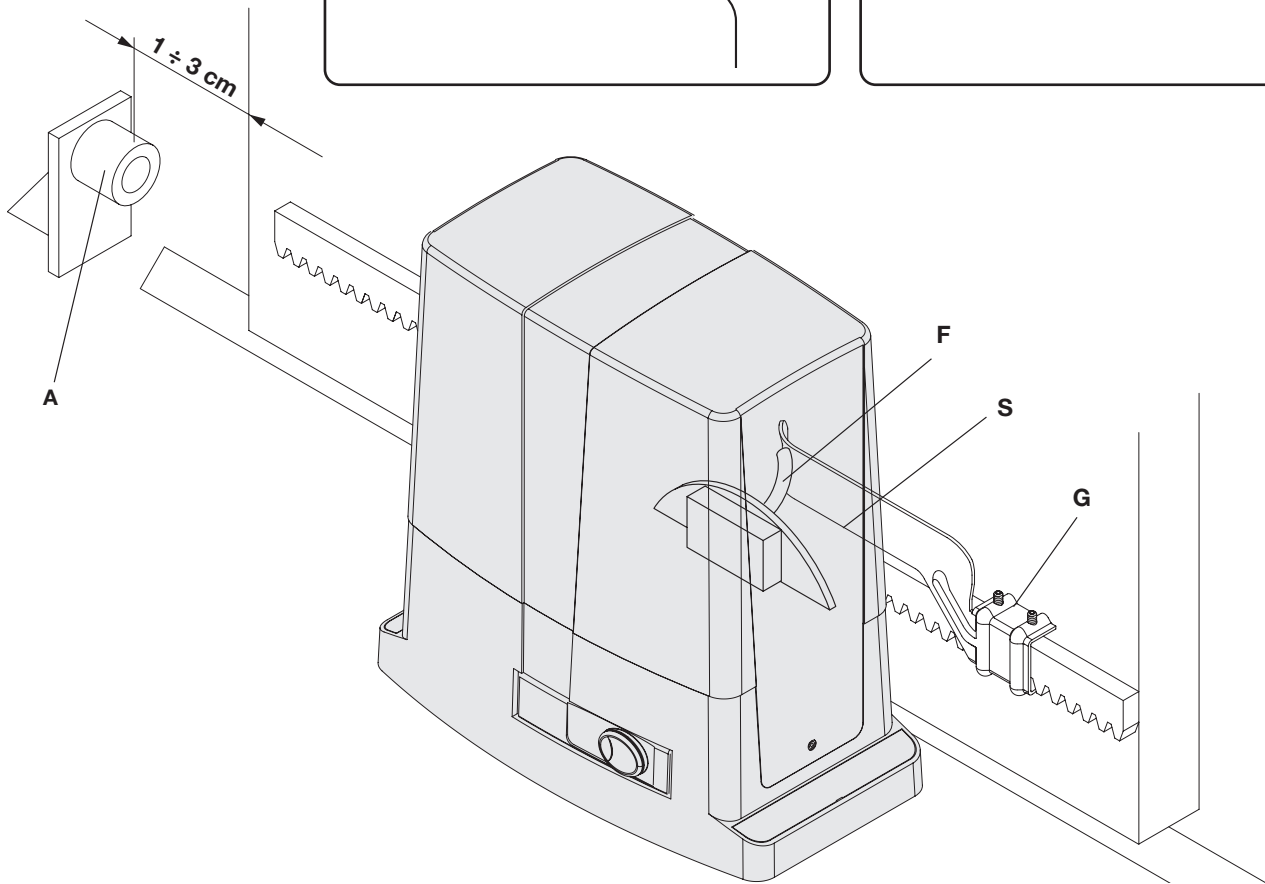
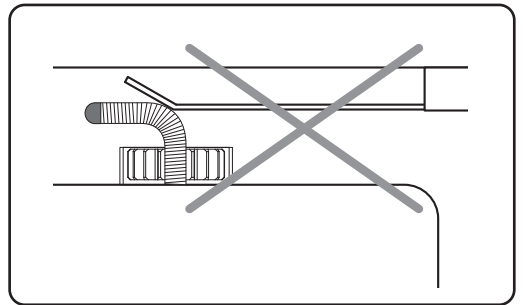
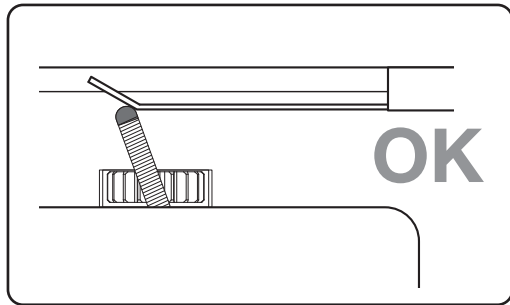

13

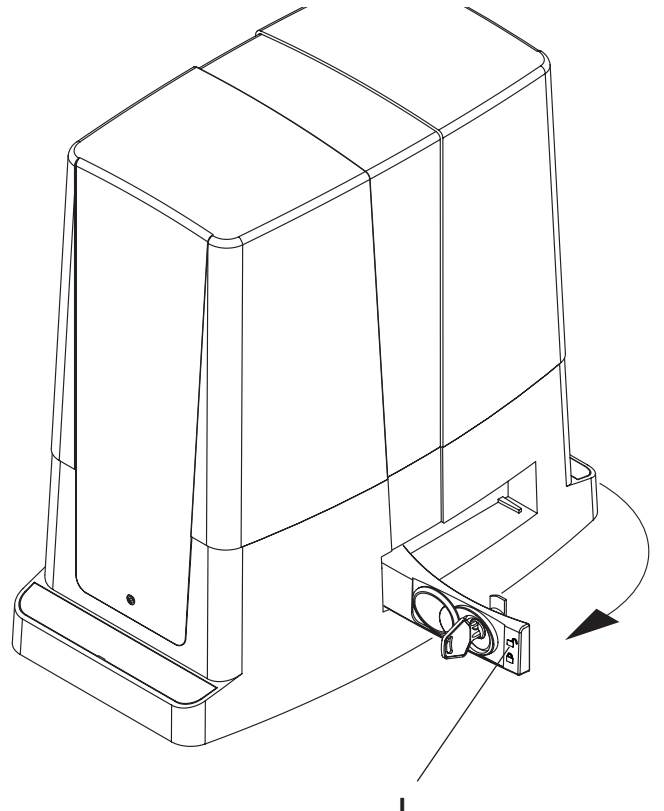
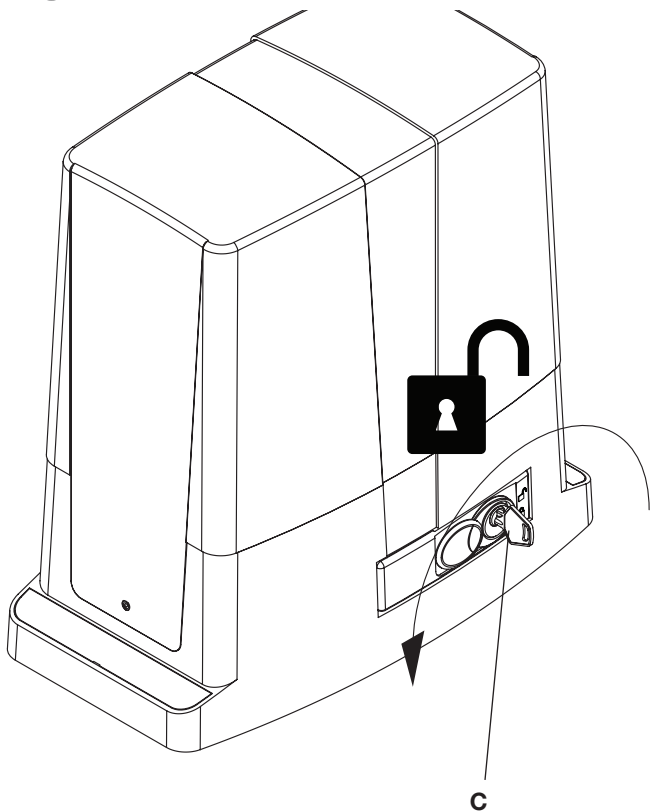

14

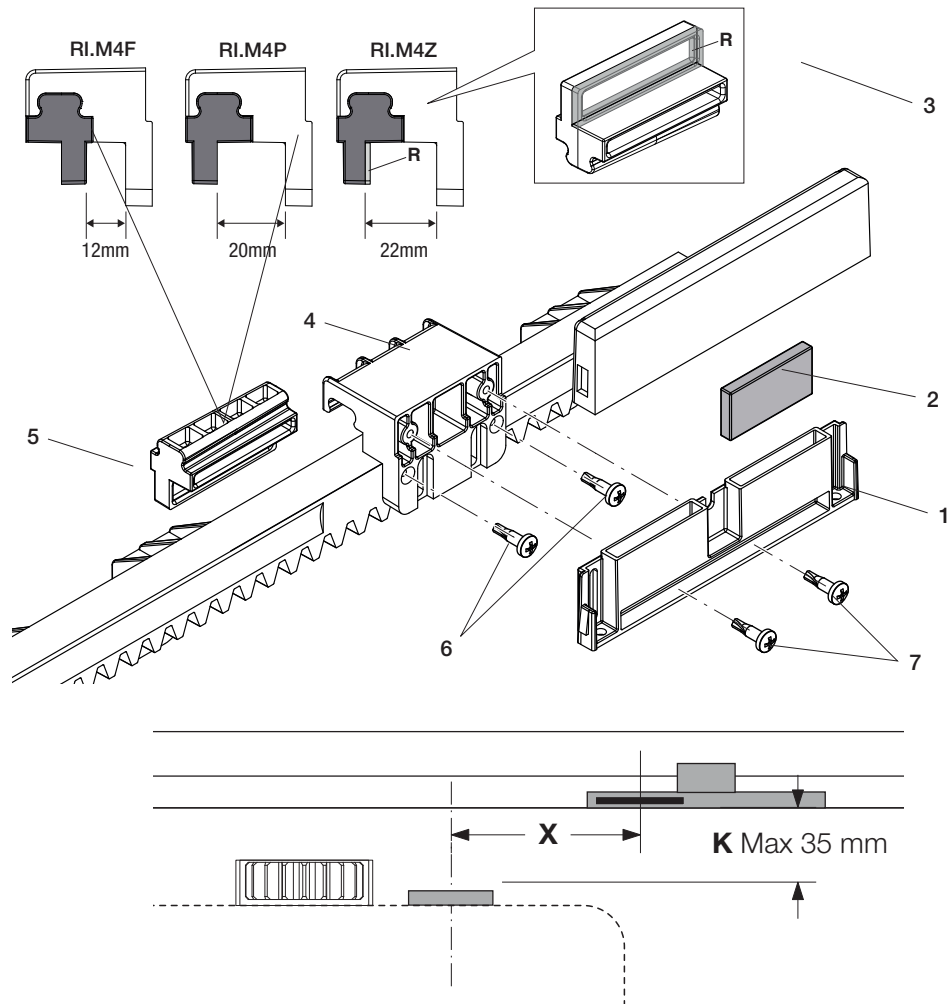

15

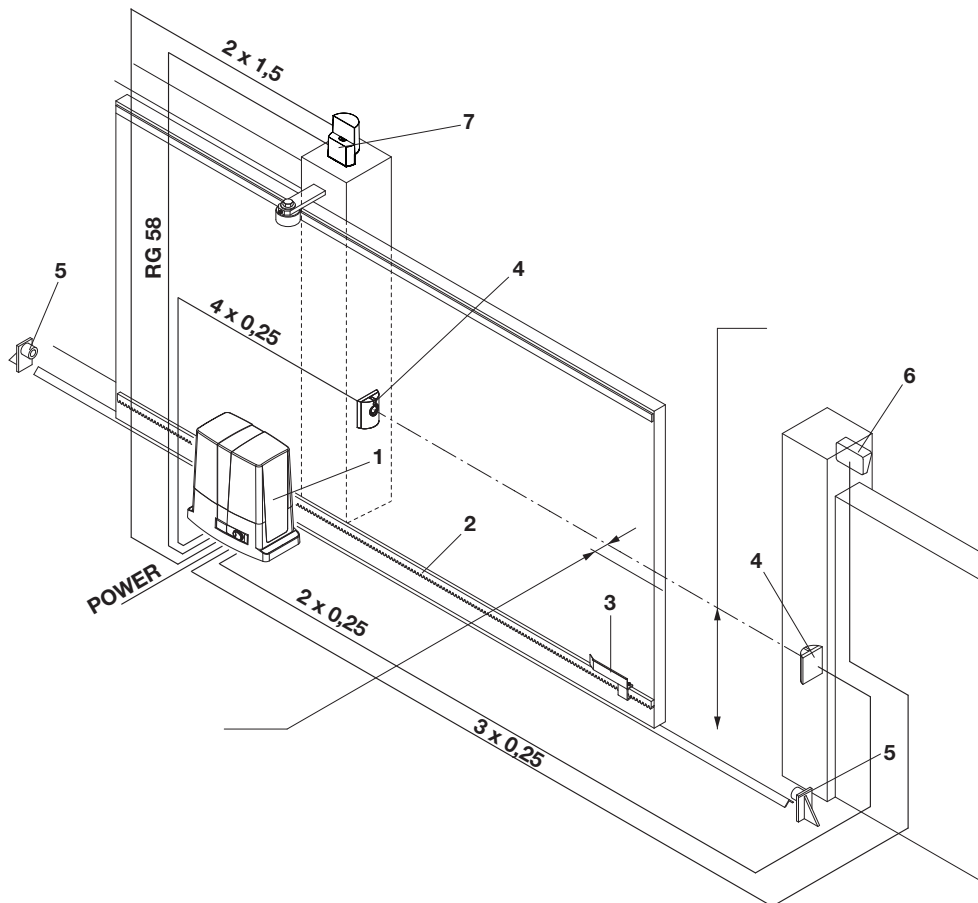

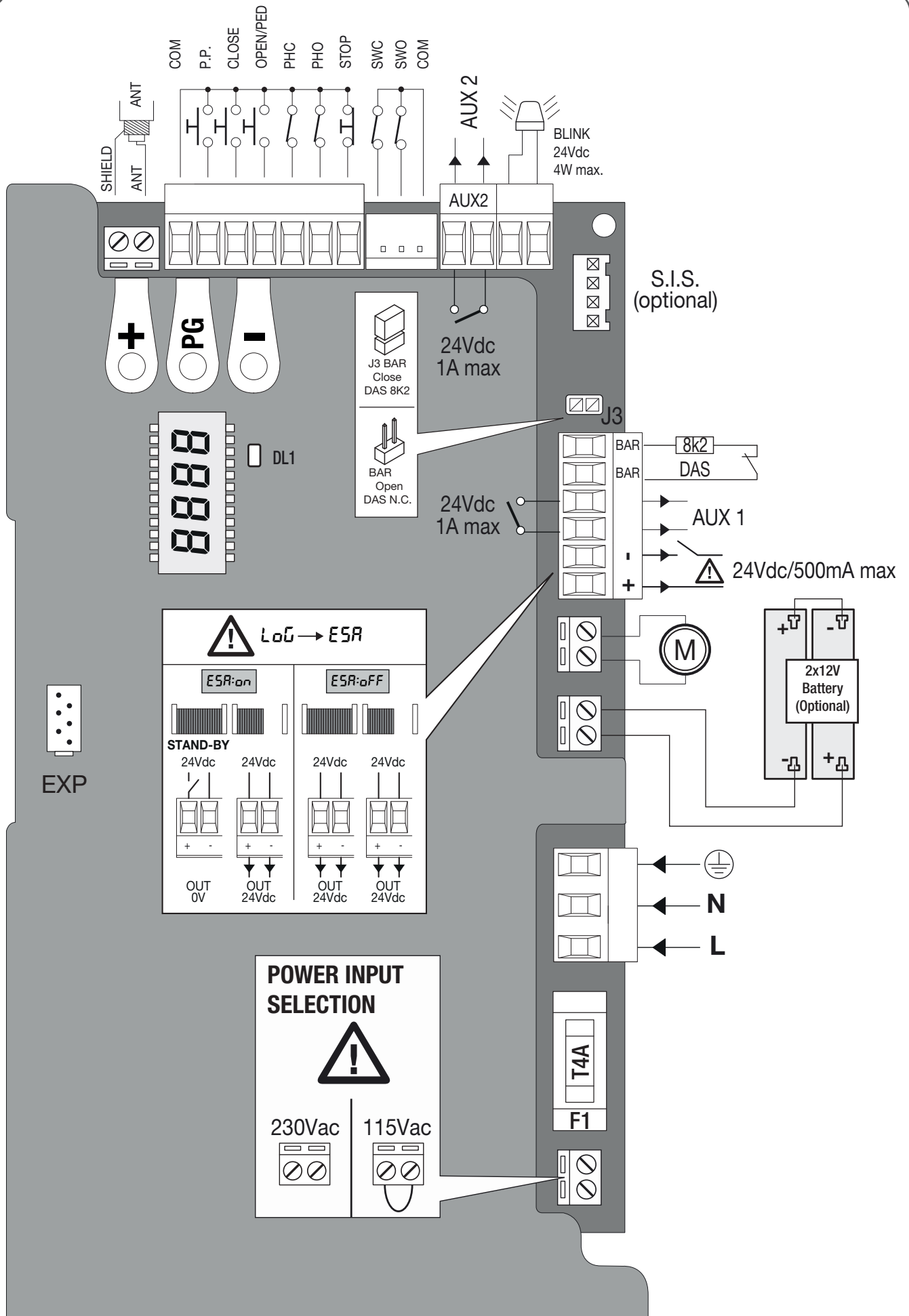

POWER INPUT SELECTION



230Vac



115Vac

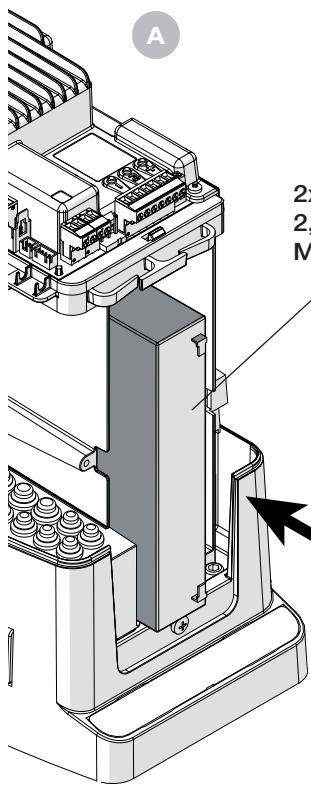
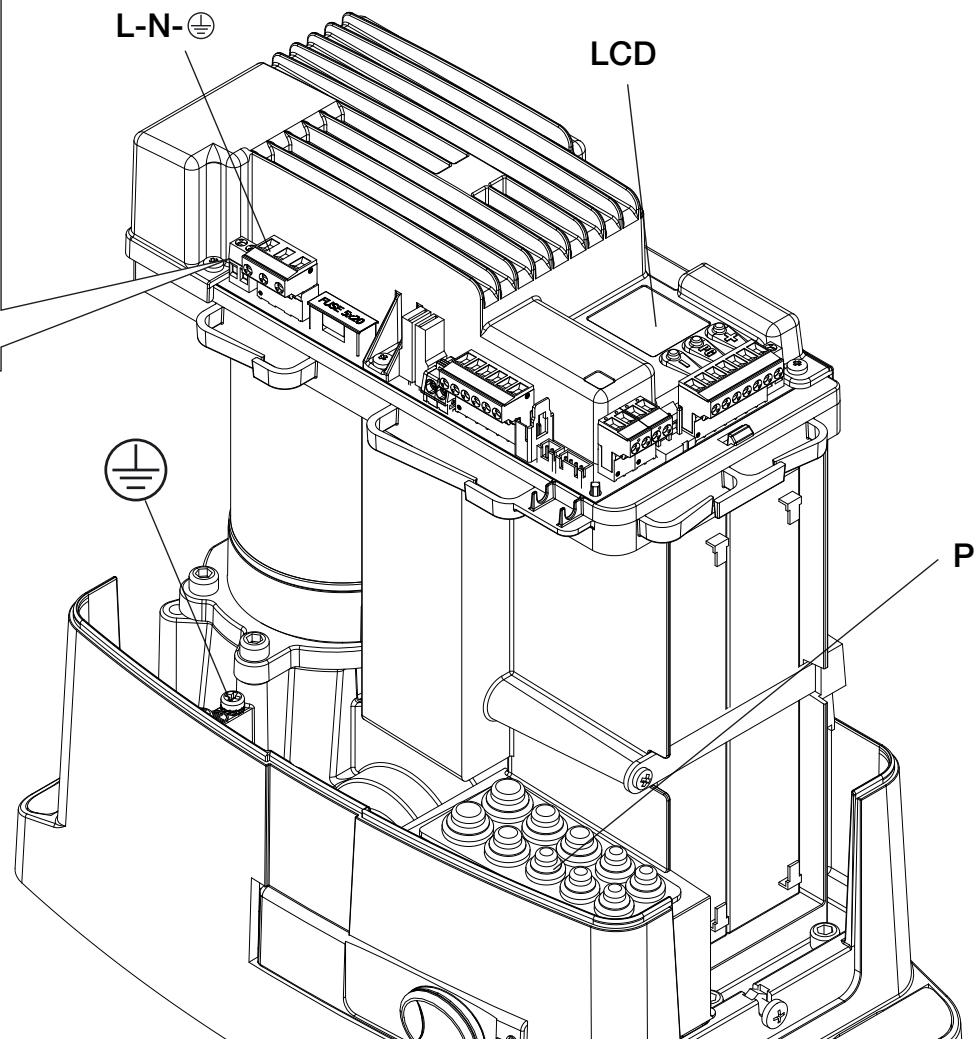

2x12V
2,1 Ah
Mod. DA.BT2

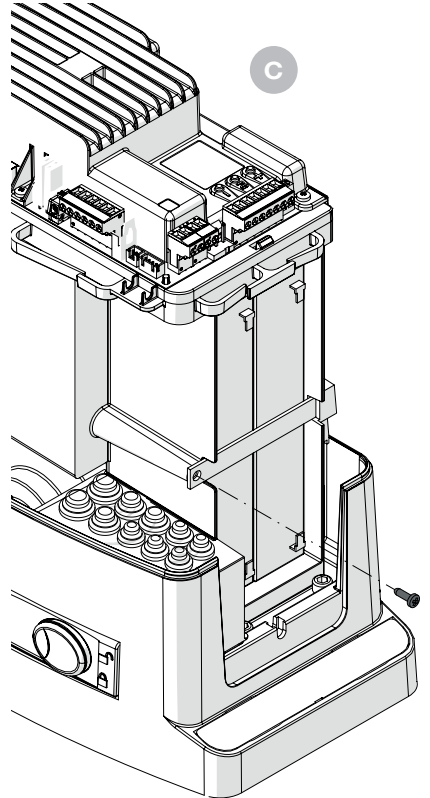
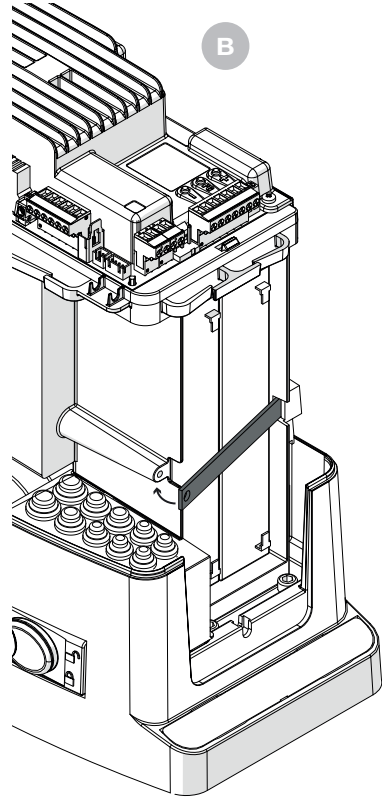
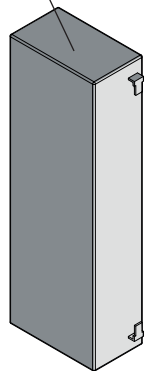

20

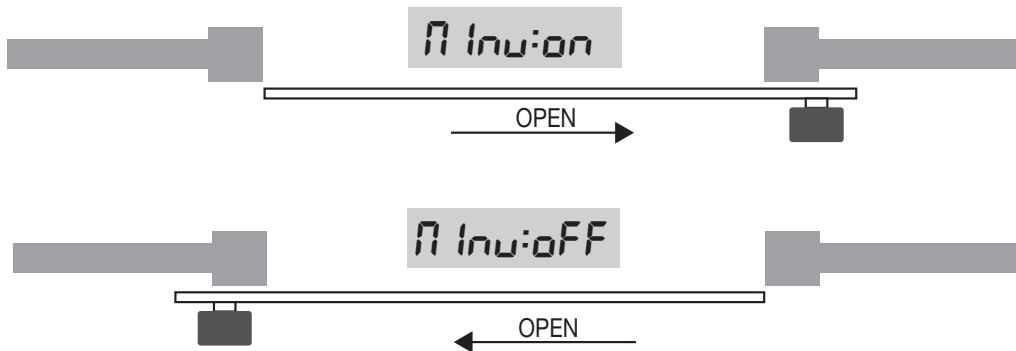

21

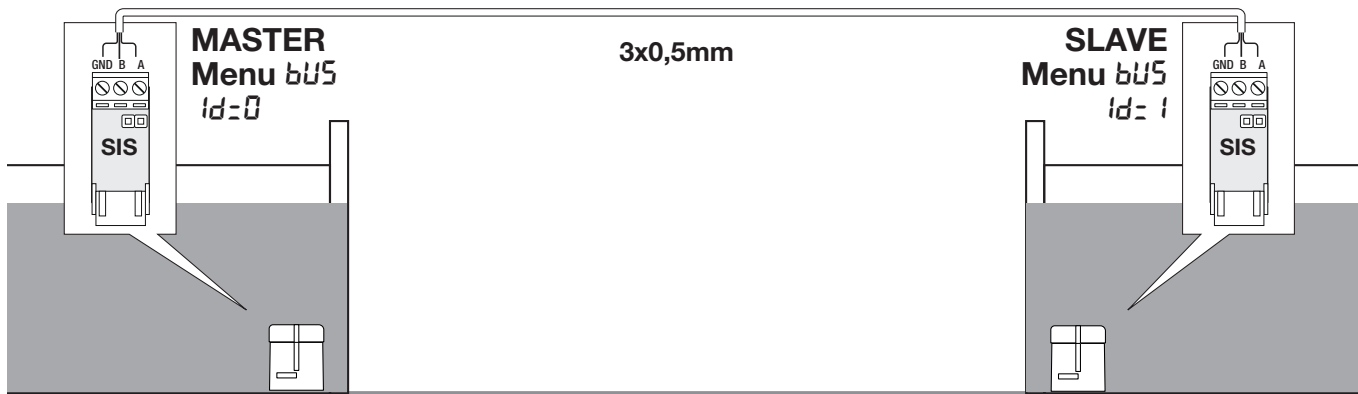

22

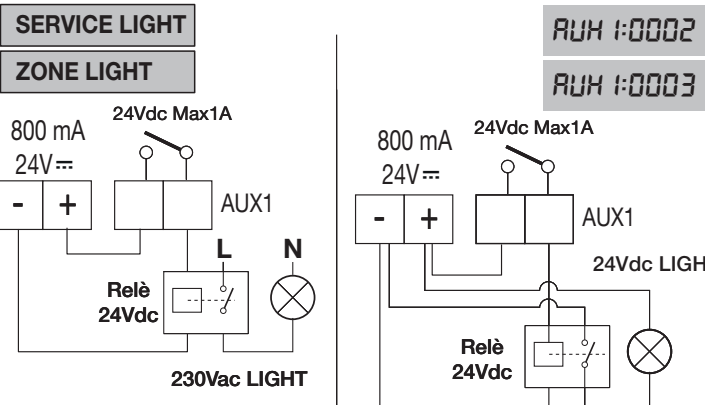
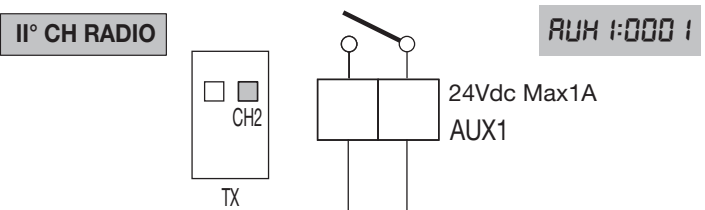
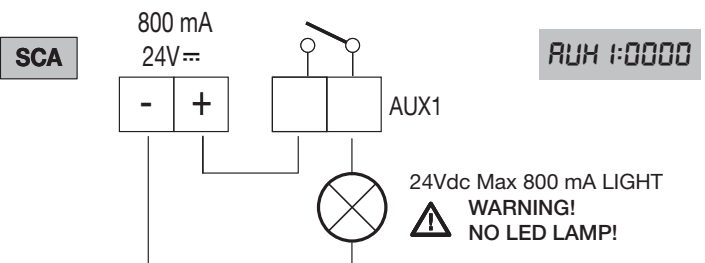

AUX 1

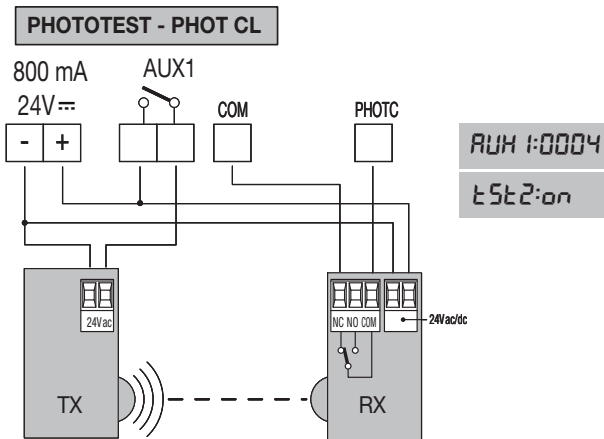
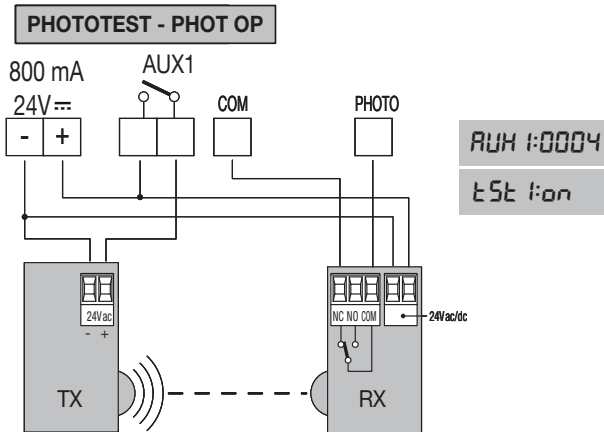

SCA

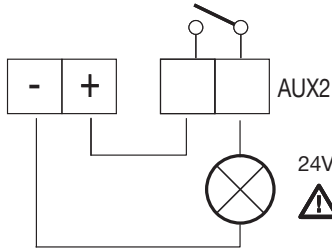

RUH2:0000

WARNING!
NO LED LAMP!

II° CH RADIO

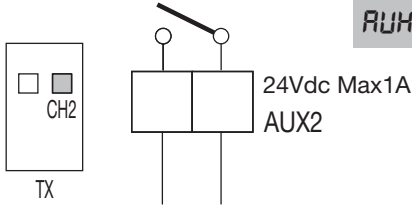

RUH2:0001

SERVICE LIGHT

ZONE LIGHT

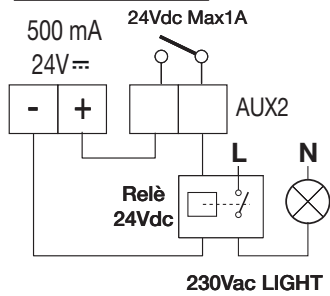

RUH1:0002

RUH1:0003

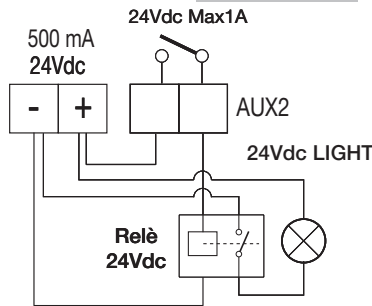

PHOTOTEST - PHOT OP

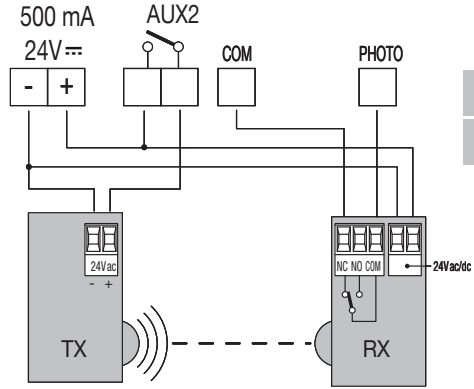

RUH2:0004

t5t1:0n

PHOTOTEST - PHOT CL

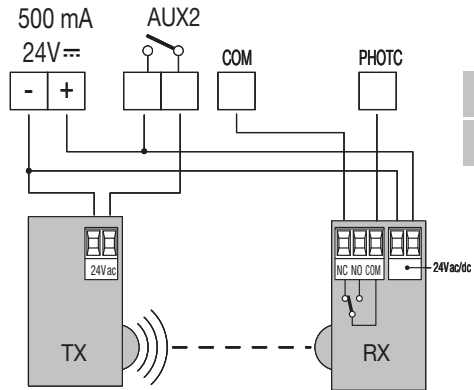

RUH2:0004

t5t2:0n

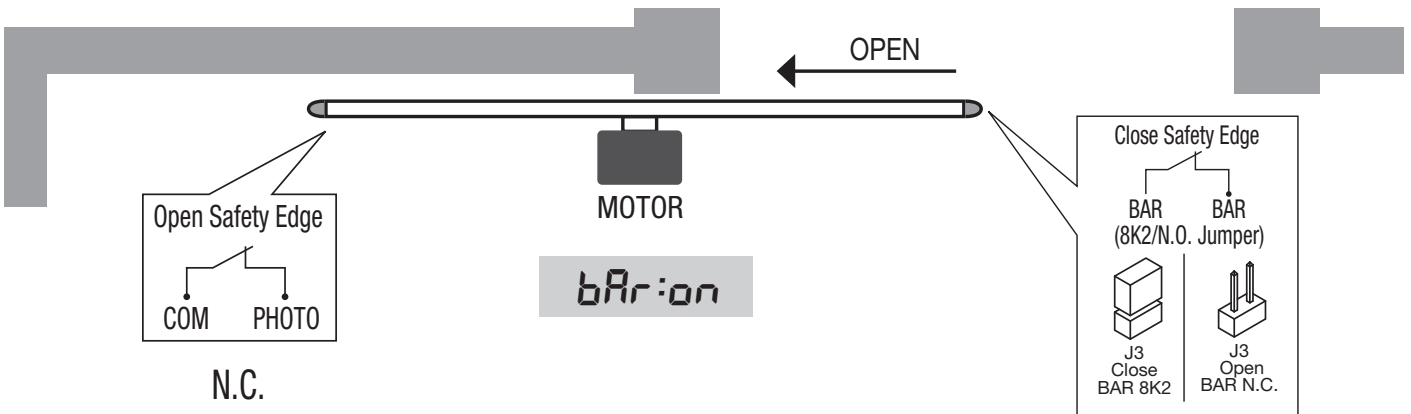

bAr:0n

Schema menu di programmazione - Menu programming layout
 Diagramm Programmiermenü - Menu de programmation
 Menú de la carta de programación - Układ menu programowania

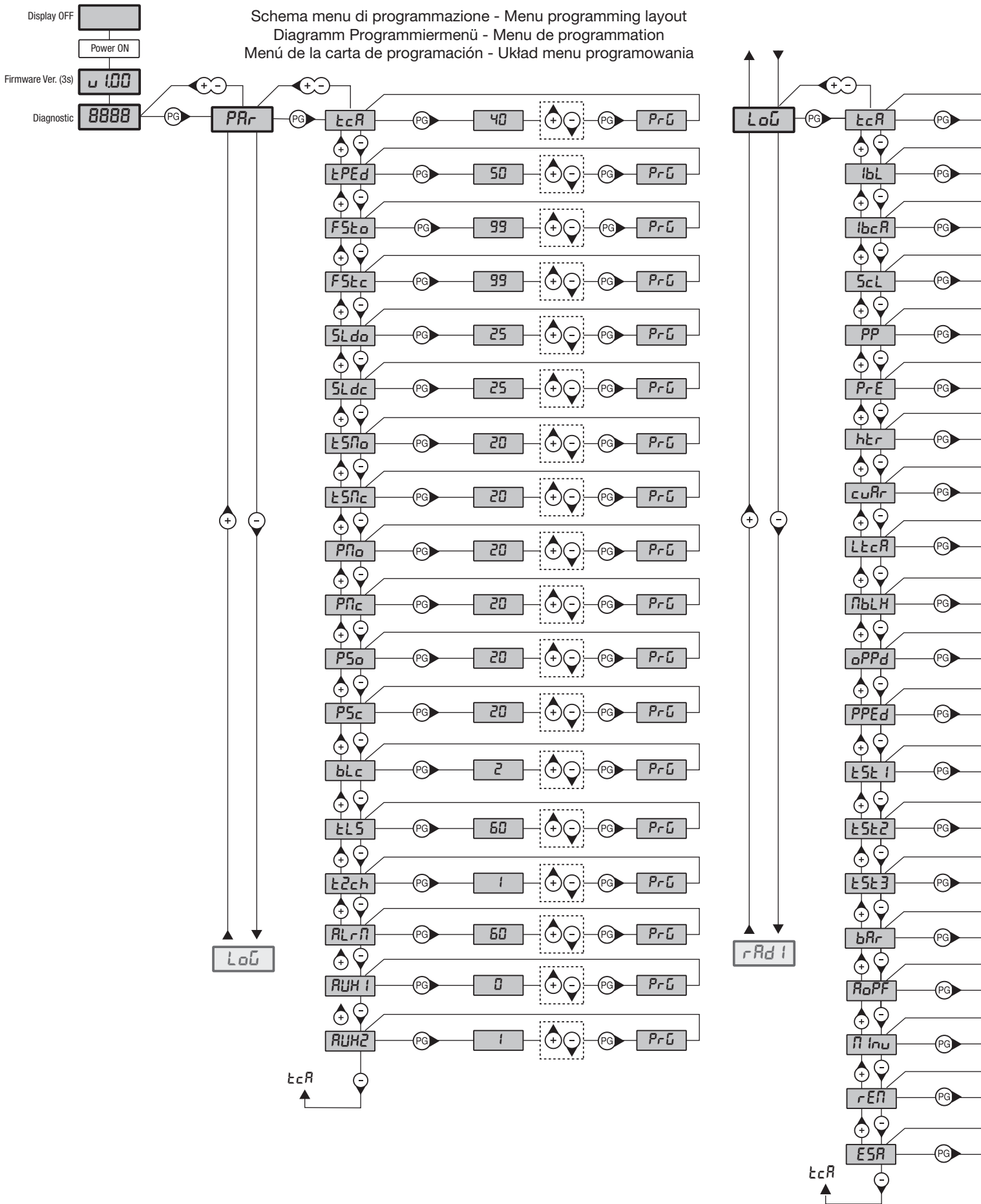



GENERAL INFORMATIONS

The product shall not be used for purposes or in ways other than those for which the product is intended for and as described in this manual. Incorrect uses can damage the product and cause injuries and damages.

The company shall not be deemed responsible for the non-compliance with a good manufacture technique of gates as well as for any deformation, which might occur during use. Keep this manual for further use.



INSTALLER GUIDE

This manual has been especially written to be use by qualified fitters. Installation must be carried out by qualified personnel (professional installer, according to EN 12635), in compliance with Good Practice and current code.

Make sure that the structure of the gate is suitable for automation.

The installer must supply all information on the automatic, manual and emergency operation of the automatic system and supply the end user with instructions for use.

GENERAL WARNINGS

Packaging must be kept out of reach of children, as it can be hazardous.

For disposal, packaging must be divided the various types of waste (e.g. carton board, polystyrene) in compliance with regulations in force. Do not allow children to play with the fixed control devices of the product.

Keep the remote controls out of reach of children.

This product is not to be used by persons (including children) with reduced physical, sensory or mental capacity, or who are unfamiliar with such equipment, unless under the supervision of or following training by persons responsible for their safety.

Apply all safety devices (photocells, safety edges, etc.) required to keep the area free of impact, crushing, dragging and shearing hazard.

Bear in mind the standards and directives in force, Good Practice criteria, intended use, the installation environment, the operating logic of the system and forces generated by the automated system.

Installation must be carried out using safety devices and controls that meet standards EN 12978 and EN 12453.

Only use original accessories and spare parts, use of non-original spare parts will cause the warranty planned to cover the products to become null and void.

All the mechanical and electrical parts composing automation must meet the requirements of the standards in force and outlined by CE marking.



ELECTRICAL SAFETY

An omnipolar switch/section switch with remote contact opening equal to, or higher than 3mm must be provided on the power supply mains.

Make sure that before wiring an adequate* differential switch and an overcurrent protection is provided.

Pursuant to safety regulations in force, some types of installation require that the gate connection be earthed.

During installation, maintenance and repair, cut off power supply before accessing to live parts.

Also disconnect buffer batteries, if any are connected.

The electrical installation and the operating logic must comply with the regulations in force. The leads fed with different voltages must be physically separate, or they must be suitably insulated with additional insulation of at least 1 mm.

The leads must be secured with an additional fixture near the terminals.

During installation, maintenance and repair, interrupt the power supply before opening the lid to access the electrical parts

Check all the connections again before switching on the power. The unused N.C. inputs must be bridged.

* 16A Circuit breaker



WASTE DISPOSAL



As indicated by the symbol shown, it is forbidden to dispose this product as normal urban waste as some parts might be harmful for environment and human health, if they are disposed of incorrectly.

Therefore, the device should be disposed in special collection platforms or given back to the reseller if a new and similar device is purchased.

An incorrect disposal of the device will result in fines applied to the user, as provided for by regulations in force.

Descriptions and figures in this manual are not binding.

While leaving the essential characteristics of the product unchanged, the manufacturer reserves the right to modify the same under the technical, design or commercial point of view without necessarily update this manual.

QUICK PROGRAMMING

NOTE: Quick programming conditions:

- Receiver memory with less than 99 stored transmitters
- Autoset never run previously.
- Only valid with ARC (Advanced Rolling Code) transmitters

If you make a mistake during the quick programming procedure, you can disconnect the power supply and restart the procedure.

Quick programming steps

- 1 Unlock the gate manually, put it in closed position with the relative end stop enabled, and lock the gate.
- 2 Supply mains voltage.
- 3 The flashing light turns on (make sure it is connected).
- 4 The system starts saving the transmitters automatically and the control unit is put on hold, waiting for a transmitter.

To skip the quick programming step and proceed with manual programming press + and - (ESC) simultaneously.

- 5 On display starts flashing the message **EH00**.
- 6 Press the hidden key of the transmitter to be saved.
- 7 **PU5h** appears on the display.
- 8 Press the key you want to associate with the receiver.
- 9 - **X01** appears on the display (if the second transmitter **EH02** is present).
- 10 Repeat steps 6 and 7 for the subsequent transmitters to store, up to 99, checking the increase on the display (example **EH 15**).
- 11 To go to the next autoset step, press the key of a previously memorised transmitter until **RUt0** appears on the display.
- 12 The message **RUt0** appears on display and the gate automatically performs 3 manoeuvres by calculating the optimal operating parameters. If the autoset operation has been completed successfully, the gate stops in open position and the message **oH** appears on display.

The maximum time for programming the first transmitter is 60 seconds.

If necessary, proceed with the manual setup of PARAMETERS and LOGIC, depending on the type of installation.

ARC CONTROL UNIT

IMPORTANT, PLEASE READ CAREFULLY:

The radio receiver in this product is compatible only with the new ARC (Advanced Rolling Code) transmitters which, thanks to 128-bit encryption ensure superior copy-security.

Storing new ARC transmitters is quite similar to that of normal rolling code transmitters with HCS coding

1) DESCRIPTION AND INTENDED USE

Gear motor 24Vdc for heavy-duty sliding gates up to 600 Kg for residential or industrial buildings, with built-in controller CP.B24-D120

We would like to remind you that if you register on the site www.beninca.com you will have access to the technical documentation updated for all the Beninca products and accessories and the guide for compiling the technical file and documents required under Annex V of the Machinery Directive, mandatory under the regulations in force..

2) SPECIFICATIONS

	BULL 424SE / BULL 424SE.S	BULL 624SE / BULL 624SE.S	BULL 1024SE / BULL 1024SE.S
Mains power supply	115/230 Vac selectable		
Motor power supply	24 Vdc		
Consumption	115Vac: 3,4A - 230Vac: 1,7A	115Vac: 3,6A - 230Vac: 1,8A	115Vac: 4,0A - 230Vac: 2,0A
Stand-by consumption	0,8 W*		
Thrust	428 Nm	650 Nm	892 Nm
Operating jogging	20°C: intensive use - 50°C: 40 cycles/h		20°C: 50 cycles/h - 50°C: 30 cycles/h
Protection level	IP44		
Operating temperature	-20°C / +50°C		
Gate max. weight	450 kg	600 kg	1000 kg
Rack module	Z14		
Opening speed	5,5 - 11 m/min	5,5 - 14 m/min	5,5 - 10,5 m/min
Noise level	<70 dB		
Lubrication	GREASE		
N° of storable TX	2048		
Central control	CP.B24-D120		
Weight	8,5 kg	8,60 kg	9,90 kg

* The control unit enters energy-saving mode (stand-by) only with ESA=ON logic and after completing any timed functions that may have been activated (TCA, courtesy light, etc.), in any case no later than 240 seconds after the end of the operation. *To activate standby mode with the gate open (TCA=OFF), it is necessary to disable the signaling functions (e.g., SCA).*

3) PRELIMINARY CHECKS

Before proceeding with installation, check the following:

- The structure (gate, pillar, guide rail) must be sturdy and stable.
- The guide rail and its wheels must be suitably sized and maintained to avoid excess friction during gate sliding.
- If available, check the CE declaration of conformity of the gate and perform the risk analysis according to the machinery directive.
- Check that the gate travel during opening/ closing is limited by sturdy mechanical stops.

4) INSTALLATION

4.1) OVERALL DIMENSIONS

Dimensions of the foundation plate are shown in Fig. 2.

IMPORTANT: It is essential to keep the distance from the rack (40 mm), in order to position and remove the actuator once the rack is fitted to the gate leaf. The types of fittings of the foundation plate are mainly the following:

4.2) INSTALLATION WITH OPTIONAL BULL.PI RAISED BEDPLATE

The BULL.PI accessory that facilitates quick fixing on existing concrete floor, is available on request.

For more information refer to the instructions supplied with the accessory.

4.3) INSTALLATION WITH ADJUSTMENT IN HEIGHT ON THE ALREADY EXISTING BASE IN CONCRETE

By using the plate as drilling template, drill 4 holes, and insert the Ø 10mm steel screw anchors for threaded bars.

Tighten the 4 threaded bars "S", M10/120mm, and anchor the screw "T" anchors by tightening the nuts "B" to floor with the corresponding washers. With reference to Fig. 3, position the foundation plate by means of the adjustment nuts "A". After carrying out the required regulations, position the motor as shown in Fig.6 and lock it, as indicated in Fig.7.

4.4) INSTALLATION WITH ADJUSTMENT IN HEIGHT ON CONCRETE BASE

With reference to Fig. 4, fit the stretcher bolts on the foundation plate and provide for a hole of adequate size.

Immerse the stretcher bolts in concrete, then remove the nuts "D" and the 11x30, large band washers "R". Move them under the plate to allow for regulations in height of the actuator (Fig. 5).

Carry out the regulations shown in Fig. 6 and lock the motor as indicated in Fig.7.

CAUTION: apart from the fitting modality used, carefully check that the actuator is steadily positioned and the materials are suited to the intended use.

4.5) RACK FIXING

Galvanized steel rack, 123x30mm.

Position the spacers D by welding or fit them to the gate with screws at 130/150mm height from the centre line of the slot used for fitting to the base on which the foundation plate is to be fixed.

Keep the pitch of teeth between the two parts of the rack; the joining with another piece of rack would make it easier to achieve (see Fig.8)

Secure the rack with the screws V making sure, once the actuator has been installed, that between rack and the drive gear there is always approx. 1mm clearance (see Fig.9); to get this clearance use the slots on the rack.

5) MANUAL OPERATION (FIG. 13)

In the event of power failure or malfunction, to manually operate the gate proceed as follows:

- After inserting the customized key C, turn it anti-clockwise and pull the lever L (opened padlock)
- The geared motor is unlocked and the gate can be moved by hand.
- To return to the normal operating mode, close the lever L again and manually activate the gate until it is geared.

6) HOW TO POSITION THE LIMIT SWITCH BRACKETS

Open manually the gate and leave approximately of 1÷3cm, depending on gate weight, between gate and positive mechanical stop A; tighten the limit stop flask S with the grains G to press the limit stop micro. Repeat the sequence with closing gate.

7) HOW TO INSTALL THE MAGNETS (BULL 424/624/1024 SE.S OR ACCESSORY MLS) FIG.14

The magnets are housed in special supports (fig.14-"A"). These magnets are to be fitted to the rack and cause the triggering of sensors when they approach them.

It is recommended to perform tests with the supports temporarily fixed before final attachment.

Proceed as follows:

- Attach the support to the rack using the two self-tapping screws 6 provided.
- Apply the adjustable insert 5 to the support 4, considering that the different orientation changes the thickness from 12mm (iron rack RI.M4F) to 20mm (plastic rack RI.M4P).
- Apply the container 1 and secure it to the support 4 using the two self-tapping screws 7 provided.
- Insert the magnet into the pocket.
- Close the snapping cover..

Notes:

In the case of an iron rack, it is recommended to use a drill to make a pilot hole.

The position of the container 1 on the support 4 is adjustable.

It is possible to directly attach the container 1 to the rack or to any flat surface.

IMPORTANT: The correct distance of the magnet (Fig.14 - X) with respect to the sensor depends on the installation characteristics. This space cannot be preset and must be adjusted on a trial basis.

In any case, the distance K must not exceed 35 mm, as a greater distance will in most cases prevent the magnetic sensor from switching.

All control units are equipped with diagnostics, which indicate, via an LCD display or LED, that the limit switch has been triggered.

By manually moving the door with the control unit powered, it is possible to check the exact stopping point.

8) CP.B24-D120 CONTROL UNIT

8.1) WIRE DIAGRAM

Wire connections shown in Fig. 17 are described hereunder:

M2 SEL. 115V	Mains power supply selection	230Vac 50/60Hz (from 207Vac to 253Vac) M2 OPEN jumper 115Vac 50/60Hz (from 102Vac to 125 Vac) M2 CLOSED jumper
L-N-GND	Mains power supply	Mains power supply input selectable via M2 jumper.
+ BATT -	Batteries	Input for connecting buffer batteries (accessory) 2x12V 2.1Ah
M11	Motor	24Vdc motor connection
+ 24 -	24 Vdc	Accessories power supply output 24Vdc 0.8 A max (respect accessories polarity).
AUX1	AUX 1 Auxiliary output	Output with N.O. contact configurable by AUX1 operating logic
BAR J3	Responsive sensor	Responsive sensor contact input Resistive sensor: Jumper "DAS" closed Mechanical sensor: Jumper "DAS" open The sensor stops the movement of the door and reverses it for about 3s. If the sensor is not used: Jumper "DAS" open, jumper between BAR terminals.
S.I.S.	Synchronisation card optional	Optional SIS card input for synchronising two opposing automations. See paragraph synchronisation of two automations.
EXP	Expansion Port	Connector for KNX or pro.UP serial expansion. To access the connector, remove the plastic protective cover with a screwdriver.
BLINK	Flashing	24Vdc output 4W max. for connection to the flashing light.
AUX2	Auxiliary output AUX 2	Output with N.O. contact configurable by AUX2 operating logic
COM	Common Inputs	Common for all control inputs.
SWO	Limit switch opens	Limit switch input OPENS (N.C. contact).
SWC	Limit switch closes	Limit switch input CLOSES (N.C. contact).
STOP	STOP	Button input STOP (N.C. contact).
PHO	Photocell opening/ closing	Photocell input active in opening and closing (N.C. contact).
PHC	Photocell closing	Photocell input active only during closing (N.C. contact)
OPEN	Opens	Input for configurable opening command as pedestrian input (N.O. contact) It is possible to connect a timer for opening in time slots.
CLOSE	Closes	Close command input (N.O. contact)
PP	Step-by-step	Step-by-Step button input (N.O. contact)
COM	Common Inputs	Common for all control inputs.
ANT-SHIELD	Antenna	Built-in radio transmitter card antenna connection (ANT-signal/SHIELD-screen).

8.2) PROGRAMMING

The programming of the various functions of the control unit is carried out using the LCD display on the control unit and setting the desired values in the programming menus described below.

The parameters menu allows you to assign a numerical value to a function, in the same way as a regulating trimmer.

The logic menu allows you to activate or deactivate a function, in the same way as setting a dip-switch.

8.2.1) TO ACCESS MANUAL PROGRAMMING

1 -Press the <PG> button to enter the first Installation menu "INST".

2 -Choose with <+> or <-> button the menu you want to select (see menu at page 10-11)

3 - Press the button <PG>, the display shows the first function available on the menu.

4 - With the <+> or <-> button, select the function you want.

5 - Press the button <PG>, the display shows the value currently set for the function selected.

6 - With the <+> or <-> button, select the value you intend to assign to the function.

7 - Press the button <PG>, the display shows the signal "PRG" which indicates that programming has been completed.

8.2.2) PROGRAMMING NOTES

Simultaneously pressing <+> and <-> from inside a function menu allows you to return to the previous menu without making any changes. Hold down the <+> key or the <-> key to accelerate the increase/decrease of the values.

Hold down the <+> key or the <-> key to accelerate the increase/decrease of the values.

After waiting 120s the control unit quits programming mode and switches off the display.

When the board is switched on, the software version is displayed for around 5 sec

The pre-set logic functions and parameters are made taking account of a typical installation.

8.3) TESTING

- Check that the safety devices work correctly.

- Check the opening/closing forces at the points set out in EN 12445 with an appropriate instrument.

- If the forces are greater, install a safety device compliant with EN12978 (e.g. safety sensitive edge) and repeat the measurements.

- Check the correct setup of the operation logic and that the manual release works properly.

8.4) PARAMETERS, LOGICS AND SPECIAL FUNCTIONS

The following tables describe the functions available on the control unit.

8.4.1) PARAMETERS (PRr)			
MENU	FUNCTION	MIN-MAX-(Default)	MEMO
t_{cA}	Automatic closing time. Enabled only with logic "TCA"=ON. At the end of the set time, the control unit commands a closing maneuver .	3-240-(40)	
t_{PEd}	The passage left open by the gate leaf during the partial opening (pedestrian) is adjusted.	10-99-(50)	
FSt_o	The opening speed is adjusted. *	50-99-(99)	
FSt_c	The closing speed is adjusted. *	50-99-(99)	
$SLdo$	Adjusts the slowdown speed of sliding door during the opening phase* (Fig.10 -slow Open).	10-50-(25)	
$SLdc$	Adjusts the slowdown speed of sliding door during the closing phase * (Fig.11 -slow Close).	10-50-(25)	
tSN_o	Sets the starting point of the slowdown during the opening phase (Fig.10- beginning of the slow Open). The value is expressed in percentage on the entire stroke. *	1-99-(20)	
tSN_c	Sets the starting point of the slowdown during the closing phase (Fig.11- beginning of the slow Close). The value is expressed in percentage on the entire stroke. *	1-99-(20)	
Pn_o	Adjusts the motor torque applied to sliding door during the opening phase.	1-99-(20)	
Pn_c	Adjusts the motor torque applied to sliding door during the closing phase.	1-99-(20)	
PS_o	Adjusts the motor torque applied to sliding door during the slowdown in opening phase (Fig.9 - Slow Open).	1-99-(20)	
PS_c	Adjusts the motor torque applied to sliding door during the slowdown in closing phase (Fig.10 - Slow Close).	1-99-(20)	
bLc	Adjusts the stopping distance after the closing and opening limit switches have been intercepted. Function only active when deceleration is enabled. 0: Minimum deceleration distance 5: Maximum deceleration distance.	0-5-(2)	
tLS	Activation time of the courtesy light contact. Value expressed in seconds. At the beginning of each maneuver the contact latches for the set time. See the description of AUX1 parameter.	1-240 (60)	
$t2ch$	Activation time of AUX1/AUX outputs when set as a second radio channel. 0: Bistable output, the output status switches each time a command is received. 1-250: Switching time in seconds	0-250-(1s)	
ALr_n	Activates the alarm output when at least one of the following inputs (STOP - PHOTA - PHOTC - BAR - SWO+SWC) remains active for the set time. One of the AUX parameters must be set to 7 (Alarm output) Value in seconds.	30-240 (60s)	
$AUX 1$	Sets the operating mode of the AUX1 output (N.O. contact) 0: SCA output (gate open indicator light). The light is off when the door is closed, flashes when the door is moving, is on when the door is open. 1: 2CH radio output. The output is controlled by the second radio channel of the built-in receiver (see RADIO menu) 2: courtesy light output (activation time is set by parameter TLS) 3: Zone light output. The contact closes for the duration of the manoeuvre and for the duration of the TCA, it only reopens when the gate is closed. ATTENTION: LED lamps 24Vdc, due to the inrush current, cannot be connected directly to the AUX1/2 outputs, use a decoupling relay. 4: accessory power supply output (for .photocell verification - coast, in combination with logics TST1-TST2-TST3) 5: flashing output 6: gate open alarm output (gate open for twice the set TCA time) 7: NC input alarm output or card error (NC=alarm not active, NO=alarm active)	0 -7 - (0)	
$AUX2$	Same settings as parameter AUX1 but referring to output AUX2 (N.O contact)	0-7 - (1)	

*** ATTENTION: A WRONG SETTING OF THESE PARAMETERS CAN BE DANGEROUS. RESPECT THE REGULATION IN FORCE!**
Measure that impact forces comply with the values laid down in regulation en 12445. change, if necessary, the operating parameters and repeat the measurements. Once you have manually modified the parameters SLDO/SLDC the controller performs a complete manoeuvre to learn the new parameters.

8.4.2) LOGICS (LOG)			
MENU	FUNCTION	ON-OFF-(Default)	MEMO
<i>EcA</i>	Enables or disables automatic closing On: automatic closing enabled Off: automatic closing disabled	(ON)	
<i>ibL</i>	Enables or disables condominium function. On: condominium function enabled. The step-by-step impulse or transmitter impulse has no effect during the opening phase. Off: condominium function disabled.	(OFF)	
<i>ibcA</i>	The multi-flat function is enabled or disabled during the TCA counting. On: the bloc of flat function is enabled. The Step-by-Step signal or the transmitter signal has no effect during the TCA counting. Off: the bloc of flat function is disabled.	(OFF)	
<i>ScL</i>	The rapid closure is enabled or disabled On: rapid closure is enabled. When the gate is open or moving, the photocell activation causes the automatic closure of the gate after 3 s. It is activated only with <i>EcA</i> :ON Off: rapid closure is disabled.	(OFF)	
<i>PP</i>	Selects the operating mode of the "Step by step button" and of the transmitter. On: Operation: OPEN > CLOSE > OPEN > Off: Operation: OPEN > STOP > CLOSE > STOP >	(OFF)	
<i>PrE</i>	Enables or disables pre-blinking. On: Pre-blinking enabled. Blinking is activated 3s before the motor starts. Off: Pre-blinking disabled.	(OFF)	
<i>htr</i>	Enabled or disables HOLD-TO-RUN function On: HOLD-TO-RUN function. The pressure of the OPENS/CLOSES button must be maintained throughout the entire manoeuvre. The opening of the STOP input stops the motor. All the safety inputs are deactivated. Off: Automatic/semiautomatic function	(OFF)	
<i>cuAr</i>	Enables or disables the cloned ARC transmitters. On: The transmitters of the AK series cloned from an already memorized ARC transmitter are enabled. Off: Cloned transmitters are not enabled.	(ON)	
<i>LtEcA</i>	Selects the operating mode of the blinking light during the time TCA On: Blinking light on during TCA Off: Blinking light off during TCA	(OFF)	
<i>nblM</i>	Sets the operating mode of the AUX outputs set as flashing output (5). On: Flashing (1s On and 1s Off) Off: Steady flashing (to be used with flashing outputs already equipped with a flashing circuit).	(OFF)	
<i>oPPd</i>	Enables OPEN input as Pedestrian input (Partial parameter TPED opening). On: OPEN input enabled as pedestrian input (PED). Off: No modification to the OPEN input	(OFF)	
<i>PPEd</i>	Enables the Step-by-Step input as a pedestrian input ON: The Step-by-Step input takes on the pedestrian function, activating a partial opening defined by the parameter TPED OFF: Step-by-Step input	(OFF)	
<i>tSt1</i>	Enables or disables checking of photocells on PHOT input, active both in closing and in opening. On: Check enabled. If the check has a negative result, no manoeuvre is commanded. See Fig.22 - "PHOTO TEST". (AUX1=4) Off: Check of photocells each time a manoeuvre is disabled. This setting requires maintenance of photocells every 6 months.	(OFF)	
<i>tSt2</i>	Enables or disables the check of photocells on PHOT C input. On: Check enabled. If the check fails, no manoeuvre will be enabled. See Fig.23 - "PHOTO TEST". (AUX1=4) Off: Check of photocells each time a manoeuvre is disabled. This setting requires maintenance of photocells every 6 months.	(OFF)	
<i>tSt3</i>	Enables or disables the TEST of the COSTA (BAR) input. The activation of the TEST function is possible only with the use of the articles SC.RF and RF/RF.SUN, consult the specific instructions. On: Test enabled. If the test has a negative result, no operation is commanded. See Fig.2 - "BAR TEST". Off: Checking disabled.	(OFF)	
<i>bAr</i>	Changing the operating mode of the PHOT O and BAR inputs in the event the sensitive edges are installed on the mobile opening and closure edges (see Fig.24). On: The PHOT O input assumes a similar function to the BAR input, but inverts motion for 3s only during the opening phase. The edge connected to the BAR input is only active during the closure phase. Off: Intervention of the sensitive edge connected to the BAR input stops movement of the door and inverts for approx. 3s, both opening and closure. The PHOT O input re-starts functioning of the photocell active on opening.	(OFF)	

R_oPF	The "forced opening in case of power cut-off" function is activated or deactivated (it can be activated only with connected and operating emergency batteries). On: Activated function. In the event of power failure, before the emergency battery completely discharged, the control unit causes an opening operation. The door remains open until the power supply is back. Off: Deactivated function.	(OFF)	
n_{lnu}	The opening direction of the motor is selected: On: Right side motor mount Off: Left side motor mount (fig.20)	(OFF)	
r_{EN}	Enables or disables remote radiotransmitters learning, as indicated in the paragraph "Remote transmitters learning". On: Remote learning enabled. Off: Remote learning not enabled.	(ON)	
ESA	Enables or disables the energy saving feature "ESA". On: once the opening or closing manoeuvre is completed, the control unit goes into the maximum energy efficiency condition, reducing absorption to a minimum, disconnecting the power transformer and the accessory outputs. Note: the ESA function is not activated if: - the battery charger board is being recharged - the AUX1 or AUX 2 logic is set to 0 and the door is open. - during the service light activation time if AUX1 or AUX 2:2. Off: Energy saving disabled. To be used if you wish to have the accessory power output always on, for example when using keyboards powered at 24 Vdc, or other devices that need to be powered at all times.	(ON)	

8.4.3) RADIO (r_{Rd} i)

MENU	FUNZIONE
pp	By selecting this function, the receiver goes in waiting (PUSH) for a transmitter code to assign to the step-step function. Press the key of the transmitter to assign to this function. If the code is valid, it is memorised and the message oH is displayed If the code is not valid, the message Err is displayed
2ch	By selecting this function, the receiver goes into waiting (PUSH) for a transmitter code to assign to the second radio channel. Press the key of the transmitter to assign to this function. If the code is valid, it is memorised ad the oH message is displayed If the code is not valid, the message Err is displayed.
PEd	When this function is selected, the receiver awaits (Push) a transmitter code to be assigned to the PED function. Press the transmitter key, which is to be assigned to this function. If the code is valid, it will be stored in memory and OK will be displayed. If the code is not valid, the Err message will be displayed.
n_{tH}	By selecting this function the LCD screen shows the number of transmitters memorized into the receiver.
c_{Lr}	By selecting this function, the receiver goes into waiting (PUSH) for a transmitter code to erase from the memory. If the code is valid, it is erased and the message oH is displayed If the code is not valid or not present in memory, the message Err is displayed
r_{Er}	Completely erases memory of the receiver. Confirmation of the operation is requested. By selecting this function the receiver goes into waiting (PUSH) for a new PGM pressure to confirm the operation. At end of erasing the oH message is displayed

8.4.4) CYCLES NUMBER (n_{RRn})

Displays the number of complete cycles (open+close) carried out by the automation.

When the <PG> button is pressed for the first time, it displays the first 4 figures, the second time it shows the last 4. Example <PG> 00 12 >>> <PG> 3456: made 123.456 cycles.

8.4.5) MAINTENANCE CYCLES (n_{RC} i)

This function enables to activate the maintenance request notice after a number of manoeuvres determined by the installer.

To activate and select the number of manoeuvres, proceed as follows:

Press button <PG>, the display will show OFF, which indicated that the function is disabled (default value).

With the buttons <+> and <-> select one of the numeric values proposed (from OFF to 100). The values are intended as hundreds of cycles of manoeuvres (for example: the value 50 indicates 5000 manoeuvres).

Press the OK button to activate the function. The display will show the message **Pr oG**.

The maintenance request is indicated to the user by keeping the indicator lamp lit up for other 10 sec after the conclusion of the opening or closing operation.

8.4.6) RESET (r_{E5})

RESET of the control unit. ATTENTION!: Returns the control unit to the default values.

Pressing the <PG> button for the first time causes blinking of the letters **rE5**, pressing the <PG> button again resets the control unit. Note: The transmitters are not erased from the receiver nor is the access password and the configuration of synchronism.

All the logics and all the parameters are brought back to default values, it is therefore necessary to repeat the autose procedure.

8.4.7) AUTOSSET (Rltō)

This function sets the optimal functioning values of the installation, at the end of the procedure, it sets the average values of torque (PMO/PMC and PSO/PSC). To carry out the AUTOSSET, proceed as follow:

a) Make sure that during the autoset there is no obstacle is in the maneuver area, if necessary, fence off the area so that persons, animals, cars, etc., cannot interrupt the procedure.

During the autoset phase, the anti-crushing function is not active, while the activation of inputs and safety devices generates an error. (paragraph 8.10)

b) select the function AUTO and press PG.

c) the control unit waits the confirmation to start the procedure "AUTO" FLASHING.

d) press PG to start the AUTOSSET procedure.

The control unit performs few maneuvers for the stroke learning and the configuration of the parameters.

In case that the procedure is not successful the message ERR will be shown. Repeat the procedure after checking the wirings and the possible presence of obstacles.

8.4.8) PASSWORD (codĒ)

It allows to type in an access protection code to the programming of the control unit.

A four-character alphanumeric code can be typed in by using the numbers from 0 to 9 and the letters A-B-C-D-E-F.

The default value is 0000 (four zeros) and shows the absence of a protection code.

While typing in the code, this operation can be cancelled at any moment by pressing keys + and - simultaneously. Once the password is typed in, it is possible to act on the control unit by entering and exiting the programming mode for around 10 minutes in order to allow adjustments and tests on functions.

By replacing the 0000 code with any other code, the protection of the control unit is enabled, thus preventing the access to any other menu. If a protection code is to be typed in, proceed as follows:

- select the Code menu and press OK.

- the code 0000 is shown, also in the case a protection code has been previously typed in.

- the value of the flashing character can be changed with keys + and -.

- press OK to confirm the flashing character, then confirm the following one.

- after typing in the 4 characters, a confirmation message "CONF" appears.

- after a few seconds, the code 0000 appears again

- the previously stored protection code must be reconfirmed in order to avoid any accidental typing in.

If the code corresponds to the previous one, a confirmation message "oH" appears.

The control unit automatically exits the programming phase. To gain access to the Menus again, the stored protection code must be typed in.

IMPORTANT: TAKE NOTE of the protection code and KEEP IT IN A SAFE PLACE for future maintenance operations.

To remove a code from a protected control unit it is necessary to enter into programming with the password and bring the code back to the 0000 default value.

IF YOU LOOSE THE CODE, PLEASE CONTACT THE AUTHORISED SERVICE CENTER FOR THE TOTAL RESET OF THE CONTROL UNIT.

8.4.9) SYNCHRONIZATION (bŭ5)

MENU	FUNCTION
Id	Sets the synchronizing number. It is possible to set a numeric value from 0 to 16. If the ID parameter is to 0 the control unit is set as MASTER, all the other values set the door as SLAVE.
Loc	Allows a door set as SLAVE to receive local commands. See paragraph 8.5 "SYNCHRONIZATION OF TWO OPPOSITE SLIDING DOORS"

8.5) SYNCHRONISATION OF TWO OPPOSITE SLIDING DOORS

It is possible to manage a system composed of two sliding doors by using for each CP.B24-D120 the specific optional control unit SIS, which must be plugged into the appropriate connector as shown in Fig. 21.

Each SIS unit must be connected to the other one by means of 3 wires by 0,5 sq.mm each, as shown in Fig.21.

One of the control unit must be set as MASTER (ID=0) and the other one as SLAVE (ID=1).

All the commands (given by transmitters, push buttons or safety devices) received by the MASTER sliding door are sent to the SLAVE sliding door, which will replicate instantaneously the behavior of the MASTER.

The logic LOC can be set in two ways:

ON: the SLAVE sliding door can accept a local command and execute an opening/closing maneuver with no effect on the MASTER sliding door.

OFF: the SLAVE sliding door do not accept any local command and so it will replicate exclusively the behavior of the MASTER sliding door.

A SLAVE sliding door with LOC set to ON can be useful in case it is occasionally necessary the partial opening of a passage which is usually managed by two synchronized doors, since that a step by step command (or OPEN/CLOSE) given to the SLAVE will have effect only on this last one, while all the other commands given to the MASTER will be replicated by the SLAVE.

The connection of the safety devices (photocells, safety edges, etc.) can be done indifferently to the MASTER unit or to the SLAVE.

8.6) TRANSMITTERS REMOTE LEARNING

If an already memorised transmitter is available in the receiver it is possible to carry out remote radio learning (without needing to access the control unit).

IMPORTANT: the procedure must be carried out with door open.The logic REM must be ON.

Proceed as follows:

1 Press the hidden key of the transmitter which is already memorised.

2 Press, within 5s, the key of the corresponding transmitter which is already memorised to associate to the new transmitter. The flashing light will turn on.

3 Press within 10s the hidden key of the new transmitter.

4 Press, within 5s, the key of the new transmitter to associate to the channel chosen at point 2. The flashing light will turn off.

5 The receiver memorised the new transmitter and immediately exits from programming.

Note: function not enabled with TO.GO 2/4 AK

8.7) FUSES

F1 =T4A - General protection fuse

8.8) BACK UP BATTERIES

The CP.B24-D120 control panel is equipped with built-in battery chargers to handle in series two 12V 2.1 Ah DA.BT2 batteries (optional - fig. 19) that allow the operation of the automation even in the case of temporary absence of mains power supply.

During normal mains operation, the card charges the batteries.

The maximum charge current is 1A, the average charge current is 300mA. (respect the polarity).

Charging time with 2.1Ah mod. DA.BT2 batteries: about 3h.

Number of cycles with charged battery for a 4m/600kg gate: about 20.

8.9) DIAGNOSTICS

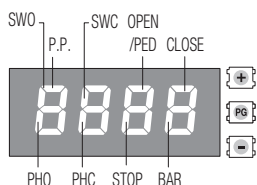

DL 1: Control panel CP.B24-D120 properly powered - Program operating/Control panel programmed. To each input is associated a line of the LCD screen which in case of activation it turns on according to the following diagram.

The N.C. inputs are represented by vertical lines.

The N.O. inputs are represented by horizontal lines.

8.10) ERROR MESSAGES

Some messages that are displayed in case of function anomalies are listed as follows:

<i>Err</i>	Generic AUTOSET error	Repeat procedure.
<i>Ecoff</i>	Modbus error	Communication error between SIS modules, check connections.
<i>ESUo</i> <i>ESUc</i>	Limit switch error in AUTOSET	The limit switch was not intercepted during the autaset phase.
<i>Err 1</i>	Motor error Check motor connections	Motor disconnected or not operating. Problem on control unit.
<i>Err 2</i>	Photocells check error	Photocells check failed, check connections and configuration.
<i>Err B</i>	INPUTS ACTIVATION Error	Activation of an input (START/OPEN/CLOSE/PED) or one of the buttons (+/-/PG) during the Autaset phase. Repeat the procedure.
<i>ANP</i>	Amperometric sensor alert	Check for obstacles or friction.
<i>Thrn</i>	Thermal sensor alert	Overheating due to permanent obstacles. Unlock the gate and check for friction points.
<i>ouLd</i>	Overload	Exceeding the maximum power. Check motor or presence of friction.
<i>bAr</i>	BAR input tripping during manoeuvring	

9) MAINTENANCE

The following table is used to record maintenance operations, improvement or repair works carried out by the expert engineer.

Date _____	Engineer's Signature _____	Stamp
Description of operation ----- -----		
Date _____	Engineer's Signature _____	Stamp
Description of operation ----- -----		
Date _____	Engineer's Signature _____	Stamp
Description of operation ----- -----		