

FW
r2.00

HW
05

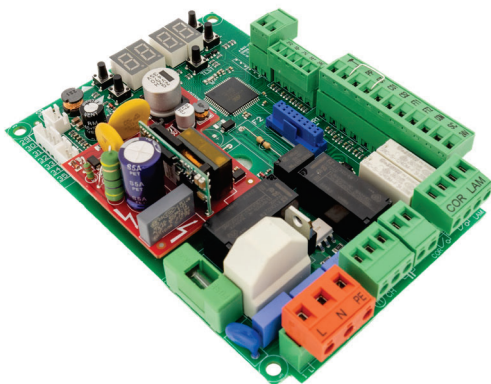

IS303 Rev.02 05/06/2026

H70/104AC - H70/105AC

centrale di comando per 1 motore 230 V~
Istruzioni originali



- IT - Istruzioni ed avvertenze per l'installatore
- EN - Instructions and warnings for the installer
- DE - Anweisungen und Hinweise für den Installateur
- FR - Instructions et consignes pour l'installateur
- ES - Instrucciones y advertencias para el instalador
- PT - Instruções e advertências para o instalador
- NLD - Aanwijzingen en waarschuwingen voor de installateur
- PL - Instrukcja i ostrzeżenia dla instalatora

 **ROGER**[®]
TECHNOLOGY

1

H70/104AC

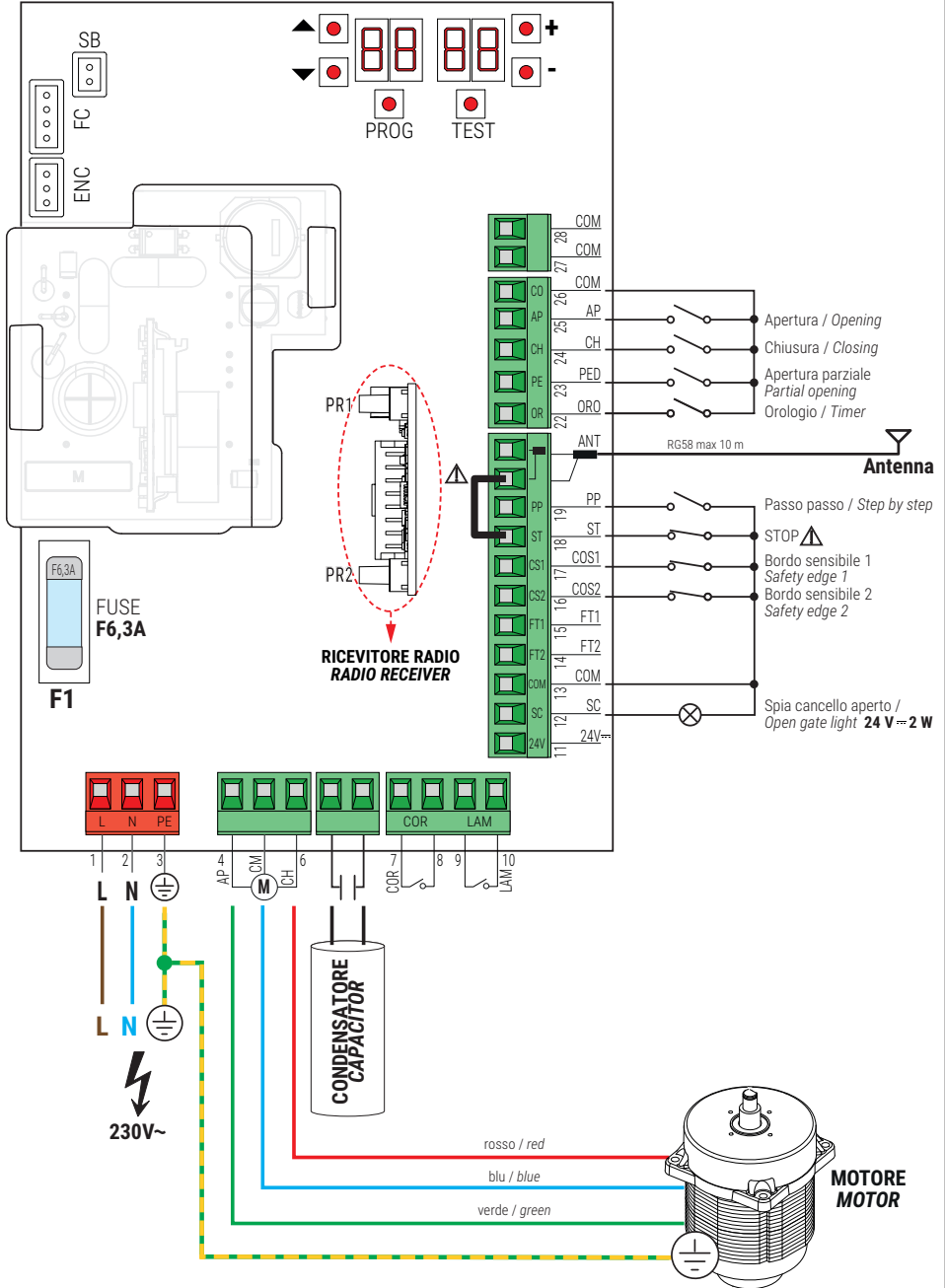

⚡ Attenzione! Il morsetto di alimentazione della centralina non deve essere utilizzato per collegare altre connessioni, in particolare connessioni per cavi esterni.

COR e LAM possono essere connessi alla bassa tensione oppure alla bassissima tensione di sicurezza, ma non è ammessa una combinazione delle due tipologie.

Attention! The power terminal of the control unit must not be used to connect other connections, especially external cable connections. COR and LAM can be connected to low voltage or safety extra-low voltage, but a combination of the two is not permitted.

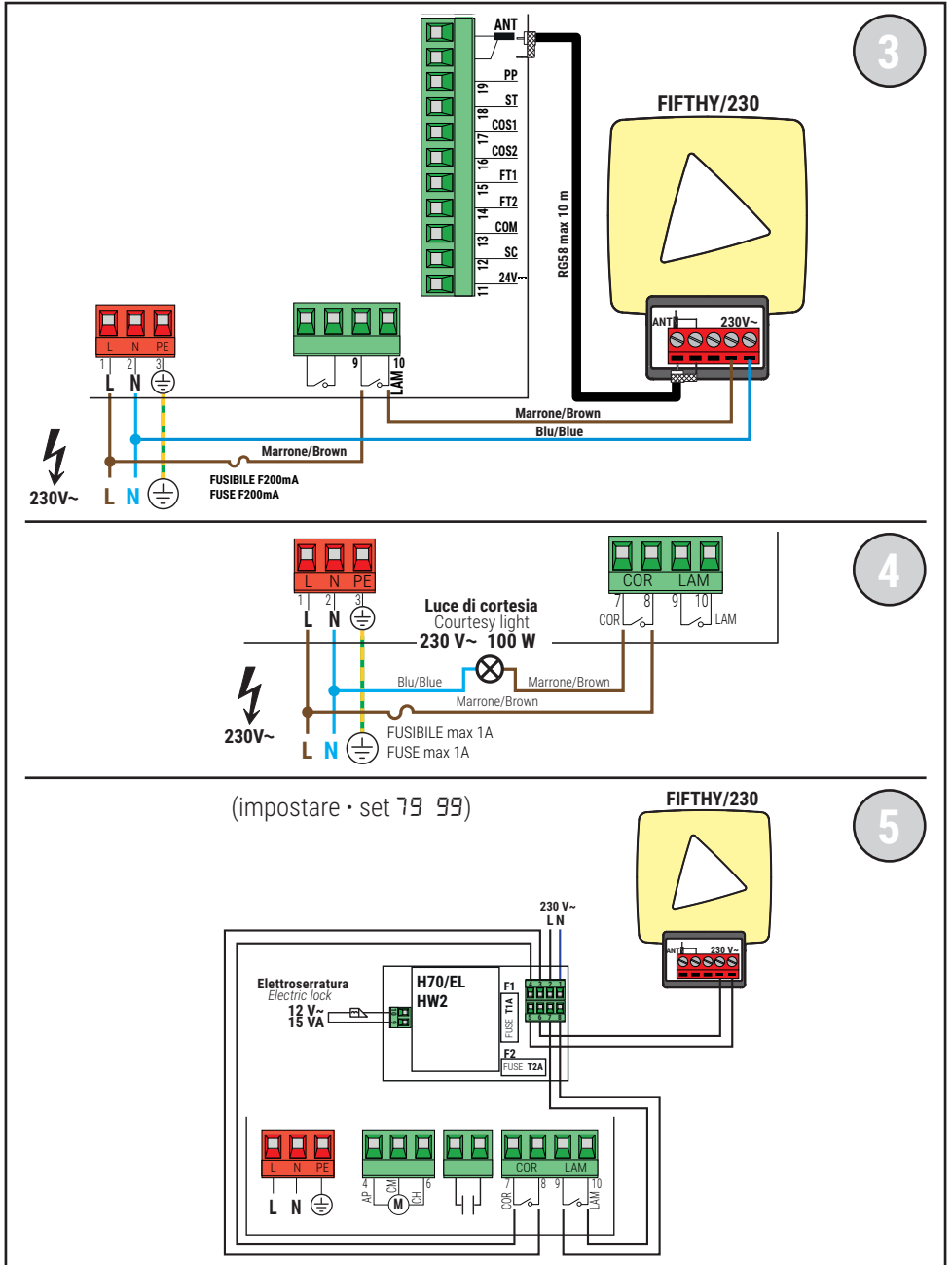

3 Updated hardware version HW05, firmware version r2.00

1. Power to the external loads and control logic is supplied by a 24V $\overline{=}$ 10W switching power supply module with integrated electronic overload protection, allowing consumption to be reduced in compliance with the new regulations regarding stand-by consumption (≤ 0.5 W)
 2. This module also contains the mains synchronisation extraction section
 3. ATTENTION! The changeover to DC power supply no longer allows the synchronisation of two pairs of F2S photocells (previously based on the 50Hz frequency of the AC power supply) to be used.
 4. Added new configurations for par. 72 to manage a new "low power" limit switch model with reduced power consumption.
 5. Added new configurations for par. 75 to handle a new "low power" optical encoder model with reduced power consumption.
 6. This version of control unit (HW5), when replaced with a H70/104AC - H70/105AC control unit of the previous model that uses standard encoders and limit switches, is compatible if appropriately configured to par. 72 and 75.
ATTENTION! Always check the positioning of the photocells and if this depends on the use of 50Hz synchronisation, which is no longer available, consider appropriate corrections.
- **ATTENTION!** The control unit is able to recognise whether magnetic limit switches (low-power version) or micro-switch limit switches are connected, and indicate whether the setting in par. 72 is correct or not. Any changes to the connection of the limit switches to the control unit must only be made when the control unit is not powered, otherwise there is a risk of malfunction
 - Par. AB is visible even if low-power mode is enabled (par. L 1 not equal to 00) but only allows values 00 and 02:
AB = 00: the SC output powers the photocells and when the control unit enters standby mode, it cuts off power to the photocells to reduce consumption
AB = 02: the SC output behaves as for AB = 00 and also allows the photo test to be performed
 - Par. 56 is not visible if low-power mode is enabled

4 Technical characteristics of product

	H70/104AC - 105AC/BOX	H70/104AC/115 - H70/105AC/115
MAINS POWER VOLTAGE	230 V \sim \pm 10% 50 Hz	115 V \sim \pm 10% 60 Hz
MAXIMUM MAINS POWER ABSORPTION	650 W	
STAND-BY CONSUMPTION	≤ 0.5 W (*)	
CONSUMPTION WAITING FOR COMMANDS WITH STAND-BY NOT ACTIVE	1,8 W (**)	
FUSES	F1 = F6,3A 250 V (5x20) motor power circuit protection External load power supply and electronically self-protected logic	
CONNECTABLE MOTORS	1	
MOTOR POWER SUPPLY	230 V \sim	115 V \sim
MOTOR TYPE	Single-phase asynchronous	
MOTOR CONTROL TYPE	Triac phase control	
MAXIMUM POWER FOR 1 MOTOR	600 W	
MAXIMUM POWER, FLASHING LIGHT	40 W 230 V \sim	
MAXIMUM POWER COURTESY LIGHT	100 W 230 V \sim	
GATE OPEN LIGHT POWER	2 W (24 V $\overline{=}$)	
MAXIMUM ACCESSORY CURRENT ABSORPTION	6 W (24 V $\overline{=}$) 300 mA	
OPERATING TEMPERATURE		
DEGREE OF PROTECTION	IP00 IP54 (H70/105AC/BOX)	IP00 IP54 (H70/105AC/115/BOX)
PRODUCT DIMENSION	98x141x40 mm Weight: 0,225 kg (H70/105AC/BOX 255x200x99)	

(*) with external loads and/or photocells connected to the SC output. Control unit mounted on M30 - H30 - R30 - G30 - R41. Control unit combined with E30.

(**) indicative consumption in the absence of connected accessories, with plug-in receiver engaged

5 Description of connections

Figures show connection diagrams.

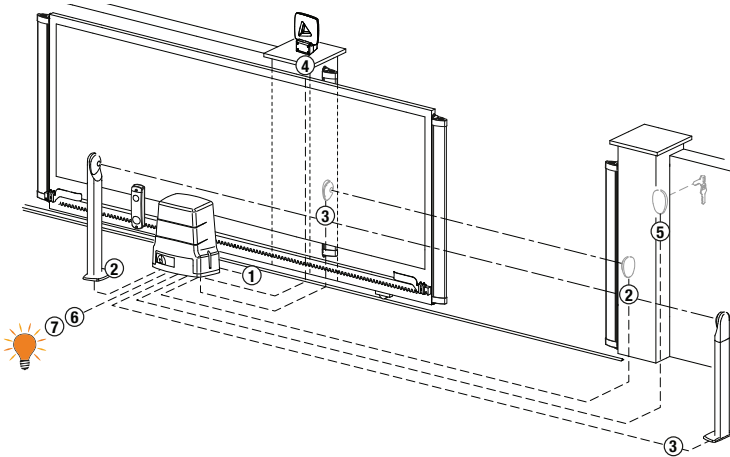

5.1 Typical installation



It is the installer's responsibility to verify the adequacy of the cables in relation to the devices used in the installation and their technical characteristics.

		Recommended cable	
1	Power supply	3x1,5 mm ² (max 15 m)	3x2,5 mm ² (max 30 m)
2	Photocell - Receiver F2ES/F2S	4x0,5 mm ² (max 20 m)	
3	Photocell - Transmitter F2ES/F2S	2x0,5 mm ² (max 20 m)	
4	LED Flashing light FIFTHY/230	2x1 mm ² (max 10 m)	
	Antenna	50 Ohm RG58 (max 10 m)	
5	Key selector R85/60	3x0,5 mm ² (max 20 m)	
	Key pad H85/TTD - H85/TDS (connecting to H85/DEC - H85/DEC2)	2x0,5 mm ² (max 30 m)	
	H85/DEC - H85/DEC2 (connecting to control unit)	4x0,5 mm ² (max 20 m) The number of conductors increases when using more than one output contact on H85/DEC - H85/DEC2	
6	Gate open indicator	2x0,5 mm ² (max 20 m)	
7	Courtesy light	2x1 mm ² (max 20 m)	
CONNECTING CONTROL PANEL H70/105AC/BOX TO MOTORS			
	Motor	4x1,5 mm ² (max 20 m)	
	Limit switches H70/105AC/BOX	4x0,5 mm ² (max 20 m)	

5.2 Electrical connections

	DESCRIPTION
	Mains power supply 230 V~ ±10% 50 Hz connection. (H70/104AC-105AC/115V/BOX : 115 V~ ± 10% 60Hz).
	For H70/104AC: ROGER MOTOR connection. N.B.: Ready wired in factory by ROGER TECHNOLOGY (H70/104AC only). H70/105AC ONLY. The gate open stop limit switch may be connected to terminals AP-CM and the gate closed stop limit switch may be connected to terminals CH-CM . When a limit switch is activated, power is cut to the motor opening/closing the gate.
	Condenser connection (see technical specifications given in the instructions for the motor).

Use only cables with double insulation (sheathed cables) for both low voltage connections (230V) and SELV safety extra-low voltage connections. The double insulation of the cables must be maintained by sheathing them only in the immediate vicinity of the terminal blocks, and they must be secured with cable ties to prevent them from coming into direct contact with hot parts (e.g. the motor). It is essential in order to guarantee the insulation to respect the correct connection of the line with the terminal marked L and the neutral with the one marked N.



6 Commands and Accessories

 If not installed, safety devices with NC contacts must be jumpered at the COM terminals, or disabled by modifying the parameters 50, 51, 53, 54, 73 and 74.

N.B.: limit switches not used with **H70/105AC** board must be disabled by parameter 72.

KEY:

N.A. (Normally Open).
N.C. (Normally Closed).

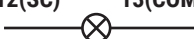
CONTACT	DESCRIPTION
7(COR) 	8 Connection for external power supply for courtesy light 230 V~ 100 W (fig. 4).
7(COR) 	8 Connection for external power supply for electric lock (potential free contact) 12 V~ max 15VA (fig. 5).
9 10(LAM) 	Connection for external power supply for flashing light (potential free contact) 230 V~ 40 W (fig. 3-5). The settings for the pre-manoeuve flashing warning signal may be selected with parameter 85, while the flashing mode is set with parameter 78.
11(24V---) 13(COM)	Power feed for external devices 6 W.
12(SC) 13(COM) 	Connection for gate open indicator lamp 24 V---= 2 W (fig. 1-2) The function of the indicator lamp is determined by parameter 88.
12(SC) 13(COM)	Connect the power supply of the photocells (both TX and RX) to these terminals, so that in stand-by they can be de-energised to reduce consumption to less than 0.5W (low power) (fig. 9). To activate the photocell test at the highest level (but only in installations where stand-by is not required), the power supply of the photocells' transmitters (TX) may be connected to terminal 12(SC) (fig. 10). Set the parameter 88 02 to enable the test function. Each time a command is received, the control unit switches the photocells off and on to check that the contact changes state correctly.

CONTACT		DESCRIPTION
14(FT2)	13(COM) 	Input (N.C.) for connecting photocells FT2 (fig. 9). The photocells FT2 are configured by default with the following settings: 53 03. During gate opening, the gate stops as long as the photocell is obstructed. The gate resumed opening when the photocell is cleared. 54 02. Movement is reversed if the photocell FT2 is triggered during gate closure. 55 00. If the photocell is obstructed, the gate cannot open. If the photocells are not installed, jumper the terminals 14(FT2) - 13(COM) or set the parameters 53 00 and 54 00.
15(FT1)	13(COM) 	Input (N.C.) for connecting photocells FT1 (fig. 9). The photocells FT1 are configured by default with the following settings: 50 00. Photocell triggers only during gate closure. Photocell is ignored during gate opening. 51 02. Movement is reversed if the photocell FT1 is triggered during gate closure. 52 00. If the photocell is obstructed, the gate cannot open. If the photocells are not installed, jumper the terminals 15(FT1) - 13(COM) or set the parameters 50 00 and 51 00.
16(COS2)	13(COM) 	Input (NC or 8 kOhm) for connecting sensing edge COS2 (fig. 1-2). The sensing edge is configured by default with the following settings: 74 00. The sensing edge COS2 (NC contact) is disabled. If the sensing edge is not installed, jumper the terminals 16(COS2) - 13(COM) or set the parameter 74 00.
17(COS1)	13(COM) 	Input (NC or 8 kOhm) for connecting sensing edge COS1 (fig. 1-2). The sensing edge is configured by default with the following settings: 73 00. The sensing edge COS1 (NC contact) is disabled. If the sensing edge is not installed, jumper the terminals 17(COS1) - 13(COM) or set the parameter 73 00.
18(ST)	13(COM) 	STOP command input (NC). The current manoeuvre is arrested if the safety contact opens. N.B.: the controller is supplied with this contact already jumpered by ROGER TECHNOLOGY.
19(PP)	13(COM) 	Step by step mode command input (N.O.). The function of the control is determined by parameter P4.
20	21(ANT) 	Antenna connector for slot-in radio receiver board. Use RG58 if an external antenna is used; maximum recommended length: 10 m. N.B.: do not make joints in cable.
22(ORO)	26(COM) 	Clock timer contact input (N.O.). When the clock function is active, the gate opens and remains open. At the end of the programmed time set with the external device (clock), the gate closes.
23(PED)	26(COM) 	Partial open control signal input (N.O.). Set by default to 30% of completely open position.
24(CH)	26(COM) 	Close command input (N.O.).
25(AP)	26(COM) 	Open control signal input (N.O.).
H70/104AC	SB	Connector (N.C.) for connecting release contact. If the motor release handle is opened, the gate stops and no command signals are accepted. Once the release handle is closed again, if the gate is in an intermediate position, the controller unit initiates the position recovery procedure (chapter 17). N.B.: Ready wired in factory by ROGER TECHNOLOGY.
	FC	Connector (N.C. contacts) for connecting mechanical limit switch (fig. 7 - detail A) or magnetic limit switch (fig. 7 - detail B). The gate stops when the limit switch is activated. N.B.: Ready wired in factory by ROGER TECHNOLOGY. NOTE: the magnetic limit switch on new installations must be of the "low power" type (to maintain low stand-by consumption)

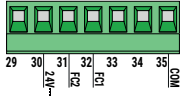
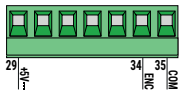
CONTACT		DESCRIPTION						
H70/104AC	ENC	Connector for connecting to encoder installed on motor. WARNING! Always disconnect from electrical power before disconnecting or connecting the encoder cable. N.B.: Ready wired in factory by ROGER TECHNOLOGY.						
H70/105AC		Inputs (N.C.) for connecting closed and open limit switches (fig. 8). Use a 4x0.5 mm ² cable to connect the limit switch to the control unit. The gate stops when the limit switch is activated. The terminal 24 V AC input may only be used to power ROGER TECHNOLOGY magnetic limit switches. The ROGER TECHNOLOGY magnetic limit switch is equipped with a plug-in connector. If used with the H70/105AC control unit, cut off the connector and connect the wires as shown in fig. 8. N.B.: if the limit switches are not installed or not used, DO NOT jumper contacts FC1-COM e FC2-COM , but disable them by par. 72. The limit switch function depends on the setting for parameter 71.						
		<table border="1"> <tr> <td>71 01</td> <td>FC1 = Opening limit switch</td> <td>FC2 = Closing limit switch</td> </tr> <tr> <td>71 00</td> <td>FC1 = Closing limit switch</td> <td>FC2 = Opening limit switch</td> </tr> </table>	71 01	FC1 = Opening limit switch	FC2 = Closing limit switch	71 00	FC1 = Closing limit switch	FC2 = Opening limit switch
	71 01	FC1 = Opening limit switch	FC2 = Closing limit switch					
71 00	FC1 = Closing limit switch	FC2 = Opening limit switch						
	Input for connecting ROGER TECHNOLOGY ENCODER (fig. 8). The optical encoder is enabled by default (75 01). WARNING! Always disconnect from electrical power before disconnecting or connecting the encoder cable.							
RECEIVER CARD	Connector for plug-in radio receiver board. The control unit has two radio remote control functions by default: <ul style="list-style-type: none"> • PR1 - step mode command (modifiable with parameter 75). • PR2 - partial opening command (modifiable with parameter 77). 							

Only use double-insulated cables (sheathed cables) for both low voltage (230V) and SELV safety extra-low voltage connections. The double insulation of the cables must be maintained by sheathing them only in the immediate vicinity of the terminal blocks, and they must be secured with cable ties to prevent them from coming into direct contact with hot parts (e.g. the motor). It is essential in order to guarantee the insulation to respect the correct connection of the line with the terminal marked L and the neutral with the one marked N.

7 Function buttons and display

UP ▲

DOWN ▼

PROG

TEST

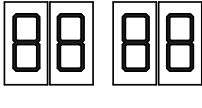

+

-

BUTTON	DESCRIPTION
UP ▲	Next parameter
DOWN ▼	Previous parameter
+	Increase value of parameter by 1
-	Decrease value of parameter by 1
PROG	Programme travel
TEST	Activate TEST mode

- Press the UP ▲ and/or DOWN ▼ buttons to view the parameter you intend to modify.
- Use the + and - buttons to modify the value of the parameter. The value starts to flash.
- Press and hold the + or - button to scroll quickly through values, to modify the parameter more quickly.
- To save the new value, wait a few seconds or move onto another parameter with the UP ▲ or DOWN ▼ button. The display flashes rapidly to indicate that the new value has been saved.
- Parameters can only be modified while the motor is not running. Parameters can be viewed at any time.

8 Switching on or commissioning

Power the control unit.
The display shows the firmware version for three seconds, and then switches to displaying the command and safety status.
See chapter 9.

9 Display function mode

• Parameter display mode

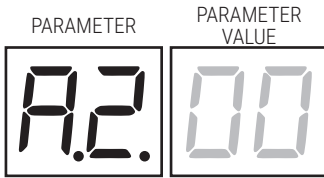

See chapter 12 for detailed descriptions of parameters.

• Command and safety device status display mode

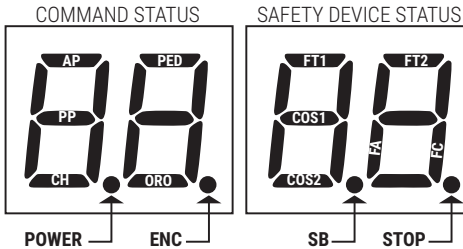

COMMAND STATUS:

The command status indicators on the display (segments AP = open, PP = step mode, CH = close, PED = partial opening, ORO= clock) are normally off. They illuminate when a command is received (e.g.: when a step mode command is received, the segment PP illuminates).

SAFETY DEVICE STATUS:

The safety device status indicators on the display (segments FT1/FT2=photocells, COS1/COS2 = sensing edge FA= gate open limit switches, FC=gate close limit switches, ENC= Encoder, SB= Release system (for H70/104AC) are normally

on. If an indicator is off, the relative device is in alarm state or is not connected. The an indicator is flashing, the relative device has been disabled with a specific parameter.

• TEST mode

The TEST mode is used to test activation of the commands and safety devices with visual confirmation.

To activate the mode, press the TEST button with the automatic gate system at rest. If the gate is moving, pressing TEST stops the gate. Pressing the button again enables TEST mode.

If the flashing light and the gate open indicator lamp illuminate for one second each time a control is used or a safety device is activated.

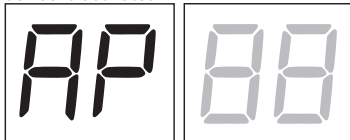

The command signal status is shown on the left hand side of the display for 5 seconds, ONLY when the respective command signal is active (AP, CH, PP, PE, OR). For example, if the gate open command is activated, the letters AP appear on the display.

The status of the safety devices/inputs is shown on the right hand side of the display. The number of the terminal relative to the safety device in alarm state flashes.

When the gate is completely open or completely closed, FA or FC is shown on the display to indicate that the gate has reached the gate open limit switch FA or gate closed limit switch FC.

Example: STOP contact in alarm state.

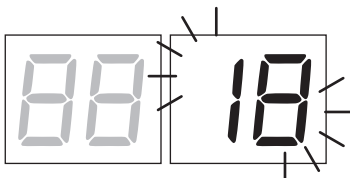

00	No safety device in alarm state, and no limit switch activated
5b (Sb)	Release handle or lock open.
18	STOP
17	Sensing edge COS1
16	Sensing edge COS2
15	Photocell FT1
14	Photocell FT2
FE	More than 3 limit switches activated
FA	Gate completely open / Gate open limit switch activated
FC	Gate completely closed / Gate closed limit switch activated

NOTA: If one or more contacts are open, the gate will not open or close. This does not apply for the limit switch signal

state, however, which is shown on the display but does not prevent normal operation of the gate. If more than one safety device is in alarm state, once the problem relative to the first device is resolved, the alarm for the next device is displayed. Any further alarm states are also displayed with the same logic. Press the TEST button again to exit test mode. After 10 seconds with no user input, the display returns to command and safety device state display mode.

• Standby mode (consumption reduction)

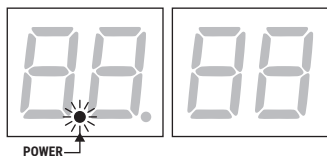

The mode is activated at the latest after 20 minutes of inactivity. The POWER LED flashes slowly.
NOTE: The stand-by activation time is adjustable in parameter $L t$; it is factory set to 20 minutes.
To reactivate the control unit press one of the **PROG** or **TEST** keys, or give a radio command.

$S t b y$	the control unit is about to go into stand-by mode
$R c t$	the control unit exits stand-by mode, the SC output feeds the photocells again

10 Travel acquisition

For the system to function correctly, the gate travel must be acquired by the control.

Before starting:

- 1. Select the position of the motor relative to the gate with the parameter τl . The default setting for this parameter is with the motor installed on the right hand side of the gate (seen from interior side).**
2. Check that the operator present function is not enabled ($R7$ 00).
3. Install mechanical stops in both the open and closed positions.
4. Move the gate into an intermediate position.
5. Press **TEST** (see TEST mode, chapter 9) and check the command signal and safety device states. If any safety devices are not installed, jumper the relative contact or disable the device from the relative parameter (50 , 51 , 53 , 54 , 73 and 74).
6. Select the appropriate self-acquisition procedure for your installation:

- A SELF-ACQUISITION PROCEDURE WITH ENCODER ENABLED, WITH OR WITHOUT LIMIT SWITCHES** (paragraph 10.1).
- B SELF-ACQUISITION PROCEDURE WITH LIMIT SWITCHES, WITHOUT ENCODER** (paragraph 10.2).
- C SELF-ACQUISITION PROCEDURE WITHOUT LIMIT SWITCHES AND WITHOUT ENCODER** (paragraph 10.3).

10.1 SELF-ACQUISITION PROCEDURE WITH ENCODER ENABLED, WITH OR WITHOUT LIMIT SWITCHES (M30-H30-R30-G30-E30 series)

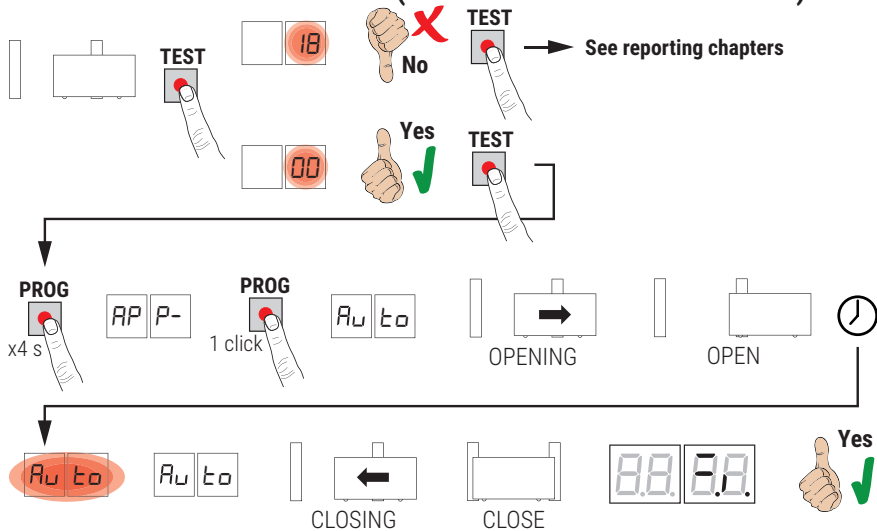

- Keep away from the photocell beam, to prevent interrupting the procedure.
- Press and hold **PROG** for 4 seconds, **RP P-** is shown on the display.
- Press **PROG** again. **Ru to** is shown on the display.
- The gate starts an opening manoeuvre at the speed selected in par. 4.1.
- Once open mechanical stop is reached or the relative limit switch is activated, the gate stops briefly.
- The message **Ru to** flashes on the display for 2 s.
- When the message **Ru to** stops flashing and is steadily lit on the display, the gate closes until the closed mechanical stop or the relative limit switch is reached.
- If the acquisition procedure is completed successfully, the display enters the command and safety device state display mode.

If the following error messages are shown on the display, repeat the acquisition procedure:

- **RP PE**: acquisition error. Press the TEST button to clear the error, and check the safety device in alarm state.



For more information, see chapter 15 "Alarms and faults".

10.2 SELF-ACQUISITION PROCEDURE WITH LIMIT SWITCHES, WITHOUT ENCODER (R30/1209 - G30/2205 series)

WARNING: Before starting the self-acquisition procedure, set parameters *11* - Deceleration space setting.

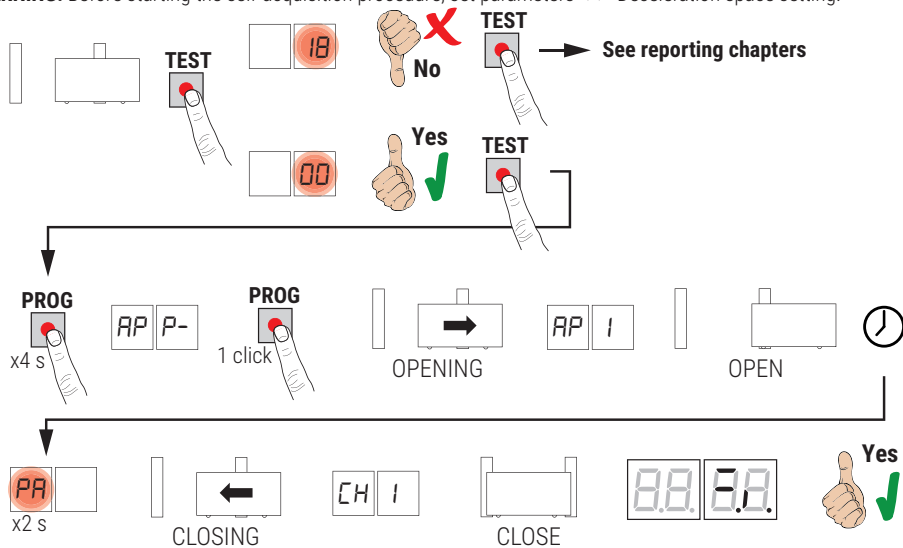

- Keep away from the photocell beam, to prevent interrupting the procedure.
- Press and hold **PROG** for 4 seconds. *AP P-* is shown on the display.
- Press **PROG** again.
- The gate starts an opening manoeuvre at the speed selected in par. 4 *1*. *AP I* is shown on the display.
- Once the relative limit switch is activated, the gate stops briefly.
- *PA* flashes on the display for 2 seconds.
- After this 2 second interval, gate closes automatically. The message *CH I* appears on the display.
- The self-acquisition procedure concludes when gate reaches the closed limit switch.
- If the acquisition procedure is completed successfully, the display enters the command and safety device state display mode.

If the following error messages are shown on the display, repeat the acquisition procedure:

- *AP PE*: acquisition error. Press the TEST button to clear the error, and check the safety device in alarm state.



For more information, see chapter 15 "Alarms and faults".

10.3 SELF-ACQUISITION PROCEDURE WITHOUT MECHANICAL OR MAGNETIC LIMIT SWITCHES AND WITHOUT ENCODER

WARNING: Before starting the self-acquisition procedure, set parameters 11 - Deceleration space setting.

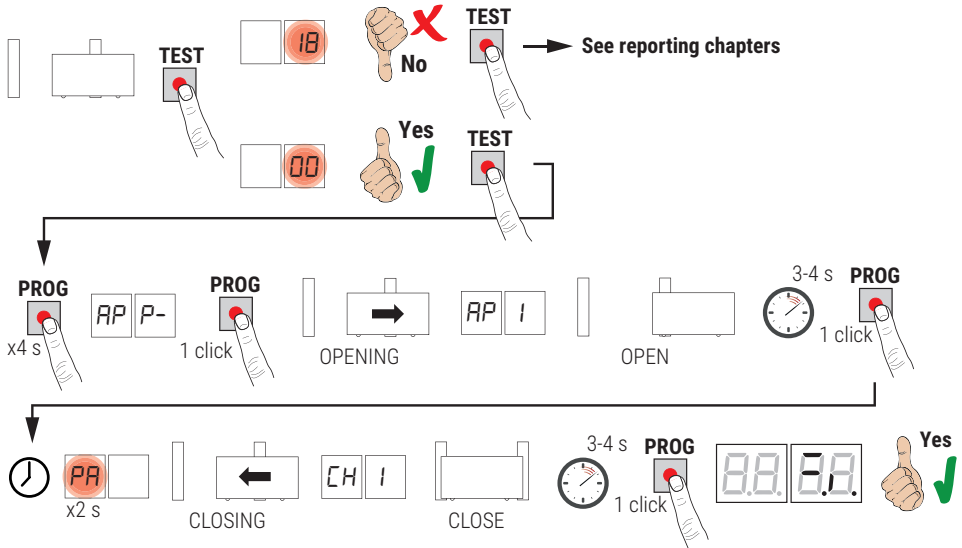

- Keep away from the photocell beam, to prevent interrupting the procedure.
- Press and hold **PROG** for 4 seconds. *AP P-* is shown on the display.
- Press **PROG** again.
- The gate starts an opening manoeuvre at the speed selected in par. 4 1. *AP I* is shown on the display.
- When the gate reaches the open position mechanical stop, wait 3-4 seconds then press **PROG**. *PA* flashes on the display for 2 seconds.
- After this 2 second interval, gate closes automatically. The message *CH I* appears on the display.
- When gate reaches the closing mechanical stop, wait 3-4 seconds then press **PROG**.
- If the acquisition procedure is completed successfully, the display enters the command and safety device state display mode.

If the following error messages are shown on the display, repeat the acquisition procedure:

- *AP PE*: acquisition error. Press the TEST button to clear the error, and check the safety device in alarm state.



For more information, see chapter 15 "Alarms and faults".

11 Index of parameters

PARAM.	FACTORY DEFAULT	DESCRIPTION	PAGE
A2	00	Automatic close after pause time (from gate completely open)	53
A3	00	Automatic gate closing after mains power outage (black-out)	53
A4	00	Selecting step mode control function (PP)	53
A5	00	Pre-flashing	53
A6	00	Condominium function for partial open command (PED)	53
A7	00	Enabling operator present function	53
A8	00	Gate open indicator / photocell test function	54
11	15	Set deceleration space (%)	54
13	10	Gate fully open/closed position control setting	54
15	30	Partial opening adjustment (%)	54
16	00	Setting additional time after direction inversion, with no encoder	54
21	30	Setting automatic closing time	54
22	20	Setting motor manoeuvre time	54
24	00	Enable double manoeuvre time	54
27	02	Setting reverse time after activation of sensing edge or obstacle detection (crush prevention)	54
28	00	Setting electric lock activation lead time	55
29	00	Setting electric lock activation time	55
30	00	Enable anti-disturbance filter for power from generator	55
31	05	Set motor torque during manoeuvre	55
32	06	Set motor torque during deceleration	55
33	08	Adjusting of motor torque	55
34	03	Set initial acceleration when opening/closing (soft-start)	55
35	08	Set torque after activation of sensing edge or obstacle detection system	55
36	03	Set initial maximum torque boost time	55
37	00	Set open/closed stop approach distance	55
38	00	Enable lock release reverse impulse	56
41	01	Set deceleration during opening/closure	56
42	60	Set obstacle detection sensitivity during manoeuvres	56
43	10	Set obstacle detection sensitivity during deceleration	56
49	00	Number of automatic closure attempts after activation of sensing edge or obstacle detection (crush protection)	56
50	00	Setting photocell mode during gate opening (FT1)	56
51	02	Setting photocell mode during gate closing (FT1)	56
52	01	Photocell (FT1) mode with gate closed	56
53	00	Setting photocell mode during gate opening (FT2)	57
54	00	Setting photocell mode during gate closing (FT2)	57

PARAM.	FACTORY DEFAULT	DESCRIPTION	PAGE
55	01	Photocell (FT2) mode with gate closed	57
56	00	Enable close command 6 s after activation of photocell (FT1-FT2)	57
60	01	Enable braking at open and closed mechanical stop/limit switch	57
61	01	Enable braking after activation of photocells	57
62	01	Enable braking after STOP command	57
63	01	Enable braking after open --> close / close --> open inversion	57
64	05	Set braking time	57
65	08	Set braking force	58
71	01	Selecting installation position of motor relative to gate (seen from interior side)	58
72	11	Enable limit switches	58
73	00	Configuring sensing edge COS1	58
74	00	Configuring sensing edge COS2	58
75	11	Configure encoder	58
76	00	Configuring radio channel 1 (PR1)	58
77	01	Configuring radio channel 2 (PR2)	58
78	00	Configuring flashing light frequency	59
79	02	Selecting courtesy light mode	59
80	00	Clock contact configuration	59
L1	04	Configure stand-by mode for reduced consumption ($\leq 0.5W$)	59
FR	00	Restoring factory default values	59
n0	01	HW version	60
n1	23	Year of manufacture	60
n2	45	Week of manufacture	60
n3	67	Serial number	60
n4	89		60
n5	01		60
n6	23		60
o0	01	View manoeuvre counter	60
o1	23		60
h0	01	View manoeuvre hour counter	60
h1	23		60
d0	01	View control unit days on counter	60
d1	23		60
P1	00	Password	60
P2	00		60
P3	00		60
P4	00		60
CP	00	Password change protection	60

12 Parameter menu

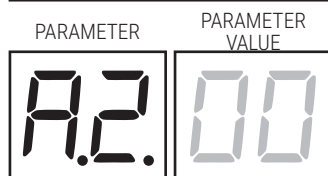

PARAMETER	PARAMETER VALUE	
A2 00		Automatic closure after pause time (from gate completely open)
00		Disabled.
0 1- 15		From 1 to 15 of gate closure attempts after photocell is triggered. Once the number of attempts set is reached, the gate remains open.
99		The gate tries to close indefinitely.
A3 00		Automatic gate closing after mains power outage
00		Disabled. The gate does not close automatically when mains power is restored.
0 1		Enabled. If the gate is NOT completely open, when mains power is restored, the gate closes after a 5 second warning signalled with the flashing light (independently of the value set with the parameter A5). The gate closes in "position recovery" mode (see chapter 17).
A4 00		Selecting step mode control function (PP)
00		Open-stop-close-stop-open-stop-close...
0 1		Condominium function: the gate opens and closes after the set automatic closing time. The automatic closing timer restarts if a new step mode command is received. Step mode commands are ignored while the gate is opening. This allows the gate to open completely and prevents the gate from closing when not required. If automatic closing is disabled (A2 00), the condominium function automatically attempts a closing manoeuvre A2 0 1.
0 2		Condominium function: the gate opens and closes after the set automatic closing time. The automatic closing timer does NOT restart if a new step mode command is received. Step mode commands are ignored while the gate is opening. This allows the gate to open completely and prevents the gate from closing when not required. If automatic closing is disabled (A2 00), the condominium function automatically attempts a closing manoeuvre A2 0 1.
0 3		Open-close-open-close.
0 4		Open-close-stop-open.
A5 00		Pre-flashing
00		Disabled. The flashing light is activated during opening and closing manoeuvres.
0 1- 10		Flashing warning signal for 1 to 10 seconds prior to every manoeuvre.
99		5 second flashing warning signal prior to closing manoeuvre.
A6 00		Condominium function for partial open command (PED)
00		Disabled. The gate opens partially in step mode: open-stop-close-stop-open...
0 1		Enabled. Partial commands are ignored during gate opening.
A7 00		Enabling operator present function
00		Disabled.
0 1		Enabled. The open (AP) or close (CH) button must be pressed continuously to operate the gate. The gate stops when the button is released.

88 00	Gate open indicator / photocell test function
00	The indicator is off when the gate is closed, and steadily lit during manoeuvres and when the gate is open.
01	The indicator flashes slowly during opening manoeuvres, and is lit steadily when the gate is completely open. It flashes quickly during closing manoeuvres. If the gate is stopped in an intermediate position, the lamp extinguishes twice every 15 seconds.
02	Set 02 if the output SC is used for the photocell test. See fig. 10.
11 15	Set motor deceleration space (%) N.B.: if no encoder is installed, repeat the travel acquisition procedure after any change made to this parameter.
01-30	From 1% to 30% of the total gate travel.
13 10	Gate fully open/closed position control setting The value selected must ensure that the gate is opened/closed correctly when it reaches the respective mechanical stop. Warning! Excessively low values cause the gate to reverse when it reaches the gate open/closed stop. N.B.: parameter visible only with encoder enabled (75 01 or 75 02) and if limit switches are not installed (72 00 or 72 02).
01-40	Motor revolutions.
15 30	Partial opening adjustment (%) N.B.: This parameter is set to 30% of total gate travel by default.
15-99	From 1% to 99% of total gate travel.
16 00	Setting additional time after direction inversion, with no encoder N.B.: parameter visible only if encoder is disabled 75 00. In the event of photocell activation or a reverse command during an opening or closing manoeuvre, the gate reverses for the elapsed manoeuvre time plus an additional time to allow the manoeuvre to be completed.
00	3 s.
01	6 s. Recommended setting for installations with hydraulic motors.
21 30	Setting automatic closing time The timer starts from the gate open state and continues for the set time. Once the set time is reached, the gate closes automatically. The timer count restarts if a photocell is triggered.
00-90	Pause time settable from 00 to 90 s.
92-99	Pause time settable from 2 to 9 min.
22 20	Set manoeuvre time N.B.: parameter visible only if encoder is disabled 75 00. Warning! Modifying this parameter influences the deceleration setting (parameter 11).
00-99	Manoeuvre time settable from 00 to 99 s.
24 00	Enable double manoeuvre time Enabling this parameter is recommended for installations with particularly long operating times. N.B.: parameter visible only if encoder is disabled 75 00.
00	Disabled.
01	Enabled.
27 02	Setting reverse time after activation of sensing edge or obstacle detection (crush prevention) This sets the reverse manoeuvre time after activation of the sensing edge or the obstacle detection system.
00-60	From 0 to 60 s.

28 00	Set electric lock activation lead time Sets the electric lock activation time before any manoeuvre. N.B.: parameter visible only if electric lock is enabled 79 99.
00-02	From 0 to 2 s.
29 00	Enable electric lock Sets duration of electric lock activation time. N.B.: parameter visible only if electric lock is enabled 79 99.
00	Disabled.
0 1-06	Enabled, with time from 1 to 6 s. This parameter must be set to a value higher than parameter 3B (if enabled).
30 00	Enable anti-disturbance filter for power
00	Disabled.
0 1	Enabled. It enables a supplementary digital filter function to improve the operation of the control unit in the event of power supply disturbance and optimise motor control.
31 05	Set motor torque during open/close manoeuvre This parameter must always be equal to or less than the value set for parameter 33.
0 1-08	I = minimum motor torque ... B = maximum motor torque.
32 06	Set motor torque during deceleration
0 1-08	I = minimum motor torque ... B = maximum motor torque.
33 08	Set motor torque boost at start of manoeuvre
0 1-08	I = minimum motor torque ... B = maximum motor torque.
34 03	Set initial acceleration when opening/closing (soft-start)
00	Disabled.
0 1-02	Enabled. The gate accelerates slowly and progressively at the start of the manoeuvre.
03-04	Enabled. The gate accelerates even more slowly and progressively at the start of the manoeuvre. N.B.: values available only if encoder is enabled (75 0 1 / 75 02). Setting a value of 04 is not recommended for heavy gates.
35 08	Set motor torque after activation of sensing edge or encoder
00	Disabled. Torque applied is the value set for parameter 3 I.
0 1-08	I = minimum motor torque ... B = maximum motor torque.
36 03	Enable maximum torque boost at start of manoeuvre If this parameter is enabled, each time the motor starts the maximum boost torque is applied for a settable period of time to allow the gate to start moving.
00-20	From 0 to 20 s.
37 00	Set open/closed stop approach distance
00	Disabled.
0 1-05	0 1 = 0.5 m long gate leaf; 02 = 1 m long gate leaf; 03 = 1.5 m long gate leaf; 04 = 2 m long gate leaf; 05 = gate leaf ≥ 2.5 m in length. If this function is enabled, the torque applied is reduced during the final part of the gate travel to reduce gate vibration when it reaches the stop. On installations with an electric lock, the torque applied is increased during the final part of the closing travel to ensure that the lock latches correctly. On installations with no electric lock, the torque applied is reduced during the final part of the gate travel to reduce gate vibration. N.B.: parameter visible only if encoder is enabled 75 0 1.

38 00	Enable electric lock release reverse impulse
00	Disabled.
01-04	Enabled. At the start of each opening manoeuvre, the control unit applies a brief closing force (settable from 1 to 4 s) to release the electric lock. Enabling the electric lock release reverse impulse function automatically enables parameters 28 01 (electric lock lead time = 1 s) and 29 03 (electric lock activation time = 3 s).
41 01	Set deceleration during opening/closure
00	Disabled.
01	Medium deceleration. N.B.: maximum settable value for 6 pole motors.
02	Maximum deceleration. IMPORTANT: DO NOT USE 6 pole motors.
42 60	Set obstacle detection sensitivity during manoeuvres The gate reverses immediately when an obstacle is detected during an opening or closing manoeuvre. N.B: set a value below 60 for 6 pole motors.
43 10	Set obstacle detection sensitivity during deceleration The gate reverses immediately when an obstacle is detected during opening or closing deceleration. N.B: set a value below 60 for 6 pole motors.
01-99	From 1% to 99%. 01 = minimum sensitivity ... 99 = maximum sensitivity.
49 00	Setting number of automatic closure attempts after activation of sensing edge or obstacle detection (crush protection)
00	No automatic closure attempts.
01-03	From 1 to 3 automatic closure attempts. We recommend setting a value equal to or lower than the value set for parameter R2. Automatic closure is only performed if the gate is completely open.
50 00	Setting photocell mode during gate opening (FT1)
00	DISABLED. Photocell is not active or not installed.
01	STOP. The gate stops and remains stationary until the next command is received.
02	IMMEDIATE REVERSE. The gate reverses immediately if the photocell is activated during gate opening.
03	TEMPORARY STOP. The gate stops as long as the photocell is obstructed. The gate resumed opening when the photocell is cleared.
04	DELAYED REVERSE. The gate stops if the photocell is obstructed. The gate closes when the photocell is cleared.
51 02	Setting photocell mode during gate closing (FT1)
00	DISABLED. Photocell is not active or not installed.
01	STOP. The gate stops and remains stationary until the next command is received.
02	IMMEDIATE REVERSE. The gate reverses immediately if the photocell is activated during gate closure.
03	TEMPORARY STOP. The gate stops as long as the photocell is obstructed. The gate resumed closing when the photocell is cleared.
04	DELAYED REVERSE. The gate stops if the photocell is obstructed. The gate opens when the photocell is cleared.
52 01	Photocell (FT1) mode with gate closed
00	If the photocell is obstructed, the gate cannot open.
01	The gate opens when an open command is received, even if the photocell is obstructed.
02	The photocell sends the gate open command when obstructed.

53 00	Setting photocell mode during gate opening (FT2)
00	DISABLED. Photocell is not active or not installed.
01	STOP. The gate stops and remains stationary until the next command is received.
02	IMMEDIATE REVERSE. The gate reverses immediately if the photocell is activated during gate opening.
03	TEMPORARY STOP. The gate stops as long as the photocell is obstructed. The gate resumed opening when the photocell is cleared.
04	DELAYED REVERSE. The gate stops if the photocell is obstructed. The gate closes when the photocell is cleared.
54 00	Setting photocell mode during gate closing (FT2)
00	DISABLED. Photocell is not active or not installed.
01	STOP. The gate stops and remains stationary until the next command is received.
02	IMMEDIATE REVERSE. The gate reverses immediately if the photocell is activated during gate closure.
03	TEMPORARY STOP. The gate stops as long as the photocell is obstructed. The gate resumed closing when the photocell is cleared.
04	DELAYED REVERSE. The gate stops if the photocell is obstructed. The gate opens when the photocell is cleared.
55 01	Photocell (FT2) mode with gate closed
00	If the photocell is obstructed, the gate cannot open.
01	The gate opens when an open command is received, even if the photocell is obstructed.
02	The photocell sends the gate open command when obstructed.
56 00	Enable close command 6 s after activation of photocell (FT1-FT2) N.B.: This parameter is only visible when low power mode is disabled.
00	Disabled.
01	Enabled. When the photocell gate FT1 is crossed, a close command is sent 6 seconds later.
02	Enabled. When the photocell gate FT2 is crossed, a close command is sent 6 seconds later.
60 01	Enable braking at open and closed mechanical stop or limit switch
00	Disabled.
01	Enabled. The gate brakes at the end of the manoeuvre against the mechanical open and/or closed stop.
61 01	Enable braking after activation of photocells
00	Disabled.
01	Enabled. The gate brakes when the photocells are activated.
62 01	Enable braking after STOP command
00	Disabled.
01	Enabled. The gate brakes when the control unit receives a STOP command.
63 01	Enable braking after open --> close / close --> open inversion
00	Disabled.
01	Enabled. The gate brakes before inverting direction when the control unit receives a close command while the gate is opening, or an open command while the gate is closing.
64 05	Set braking time WARNING: check carefully that the chosen value is appropriate to the model of motor used.
01-20	Settable from 1 to 20 tenths of a second.

65 08	Set braking force WARNING: preferably set low values to ensure that the gate stops correctly.
04-08	4 = minimum force ... 8 = maximum force.
71 01	Selecting installation position of motor relative to gate (seen from interior side)
00	Motor installed on left.
01	Motor installed on right.
72 11	Enable limit switches N.B.: if this parameter is modified, disconnect from 230 V~ mains power, wait for the display to turn off then reconnect to mains power. Repeat acquisition procedure. The HW5 version control unit can operate with standard magnetic limit switches or "low power", provided it is appropriately configured.
00	No limit switch installed.
01	Gate open and close limit switches installed (micro-switch or magnetic standard model).
02	Gate open limit switches installed (micro-switch or magnetic standard model).
11	Opening and closing limit switches installed (magnetic "low power" version).
12	Opening limit switches installed (magnetic "low power" version).
73 00	Configuring sensing edge COS1
00	Sensing edge NOT INSTALLED.
01	NC contact (normally closed). The gate reverses only when opening.
02	Contact with 8k2 resistor. The gate reverses only when opening.
03	NC contact (normally closed). The gate always reverses.
04	Contact with 8k2 resistor. The gate always reverses.
74 00	Configuring sensing edge COS2
00	Sensing edge NOT INSTALLED.
01	NC contact (normally closed). The gate reverses only when closing.
02	Contact with 8k2 resistor. The gate reverses only when closing.
03	NC contact (normally closed). The gate always reverses.
04	Contact with 8k2 resistor. The gate always reverses.
75 11	Configure encoder N.B.: if no encoder is installed, time based control is used. if this parameter is modified, disconnect from 230 V~ mains power, wait for the display to turn off then reconnect to mains power. Repeat acquisition procedure. The HW5 version control unit can operate with standard optical encoders or "low power" optical encoders, provided they are appropriately configured. No different configuration is required in the case of magnetic encoders.
00	No encoder installed.
01	Optical encoders installed (8 pulses/revolution, standard version).
02	Magnetic encoders installed (1 pulse/revolution). Only the E30 series uses magnetic encoders.
11	Installed "low power" optical encoders (8 pulses per revolution).
76 00	Configuring radio channel 1 (PR1)
77 01	Configuring radio channel 2 (PR2)
00	STEP MODE.
01	PARTIAL OPENING.
02	OPENING
03	CLOSING.

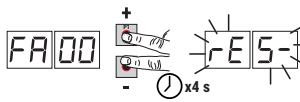
04	STOP.
05	Courtesy light. The output COR is managed from the remote control The light remains lit as long as the remote control is active. The parameter 79 is ignored.
06	Courtesy light ON-OFF (PP). The output COR is managed from the remote control. The remote control turns the courtesy light on and off. The parameter 79 is ignored.
07	FLASHING LIGHT. The FLASHING LIGHT output is managed from the remote control. The light remains lit as long as the remote control is active. The parameter 78 is ignored.
08	FLASHING LIGHT ON-OFF. The FLASHING LIGHT output is managed from the remote control. The remote control turns the courtesy light on and off. The parameter 78 is ignored.
78 00	Configuring flashing light frequency
00	The frequency is set electronically from the flashing light unit.
01	Slow flash.
02	Light flashes slowly when gate opens, rapidly when gate closes.
79 02	Selecting courtesy light mode
00	Disabled.
01	PULSE. The courtesy light illuminates briefly at the start of each manoeuvre.
02	ACTIVE. The light remains lit for the entire duration of the manoeuvre.
03-90	From 3 to 90 s. The light remains lit for the time period set after the manoeuvre is completed.
92-98	From 2 to 8 minutes. The light remains lit for the time period set after the manoeuvre is completed.
99	ELECTRIC LOCK. Enables output COR for use with electric lock (fig. 5).
80 00	Clock contact configuration When the clock function is active, the gate opens and remains open. At the end of the programmed time set with the external device (clock), the gate closes.
00	When the clock function is active, the gate opens and remains open. Any command signal received is ignored.
01	When the clock function is active, the gate opens and remains open. Any command signal received is accepted. When the gate returns to the completely open position, the clock function is reactivated.
L1 04	Configure stand-by mode for reduced consumption (≤0.5W) Determines the waiting time without activity before activating low consumption (switching off the SC output, switching off the display). With automation fully open and paused for automatic reclosing, stand-by is not activated, as it is still an active phase of automatic operation.
00	Stand-by mode disabled (only for industrial installations)
01	Stand-by activation after 5 minutes of inactivity
02	Stand-by activation after 10 minutes of inactivity
03	Stand-by activation after 15 minutes of inactivity
04	Stand-by activation after 20 minutes of inactivity
FA 00	Restoring factory default values NOTE: This procedure is only possible if a data protection password has NOT been set; if one is stored, it must first be unlocked by entering the values P1, P2, P3, P4 (confirmed by the display showing CP 00).
	 <p>Warning! Restoring default settings cancels all settings made previously except for parameter P1: after restore, check that all parameters are suitable for the installation.</p> <ul style="list-style-type: none"> • Press the PLUS + and MINUS - button. • The display flashes after 4 s rE5-. <p>• The default factory settings have now been restored.</p> <p>Note: it is possible to reset the parameters in a second way: when the control unit is switched on, before the firmware version appears on the display, press and hold down the ▲ (UP ARROW) and ▼ (DOWN ARROW) buttons for 4s.</p>

Identification number The identification number consists of the values of the parameters from $n0$ to $n6$. N.B.: The values shown in the table are indicative only.	
$n0$ 01	HW version.
$n1$ 23	Year of manufacture.
$n2$ 45	Week of manufacture.
$n3$ 67	Example: 01 23 45 67 89 01 23
$n4$ 89	
$n5$ 01	
$n6$ 23	

View manoeuvre counter The number consists of the values of the parameters from $a0$ to $a1$ multiplied by 100. N.B.: The values shown in the table are indicative only.	
$a0$ 01	Manoeuvres performed.
$a1$ 23	Example: 01 23 x100 = 12.300 manoeuvres.

View manoeuvre hour counter The number consists of the values of the parameters from $h0$ to $h1$. N.B.: The values shown in the table are indicative only.	
$h0$ 01	Manoeuvre hours.
$h1$ 23	Example: 01 23 = 123 hours.

View control unit days on counter The number consists of the values of the parameters from $d0$ to $d1$. N.B.: The values shown in the table are indicative only.	
$d0$ 01	Days with unit switched on.
$d1$ 23	Example: 01 23 = 123 days.

Password Setting a password prevents unauthorised persons from accessing the settings. With password protection active ($CP=01$), parameters may be viewed, but the values CANNOT be modified. <u>Only a single password is used to control access to the gate automation system.</u> WARNING: Contact the Technical Support Service if you lose your password.	
$P1$ 00 $P2$ 00 $P3$ 00 $P4$ 00	<p>Password activation procedure:</p> <ul style="list-style-type: none"> • Enter the desired values for parameters $P1$, $P2$, $P3$ and $P4$. • Use the UP ▲ and/or DOWN ▼ buttons to view the parameter CP. • Press and hold the + and - buttons for 4 seconds. • The display flashes to confirm that the password has been saved. • Switch the control unit off and on again. Check that password protection is activated ($CP=01$). <p>Temporary unlock procedure:</p> <ul style="list-style-type: none"> • Enter the password. • Check that $CP=00$. • Password protection is reactivated after 30 minutes of inactivity on the buttons around the display, or immediately when the system is switched off and on again. <p>Password cancellation procedure:</p> <ul style="list-style-type: none"> • Enter the password ($CP=00$). • Save the values $P1$, $P2$, $P3$, $P4 = 00$ • Use the UP ▲ and/or DOWN ▼ buttons to view the parameter CP. • Press and hold the + and - buttons for 4 seconds. • The display flashes to confirm that the password has been cancelled (the values $P1$ 00, $P2$ 00, $P3$ 00 and $P4$ 00 indicate that no password is set). • Switch the control unit off and on again ($CP=00$).

CP 00	Changing password
00	Protection deactivated.
01	Protection activated.

13 Example installation with two opposing automation systems

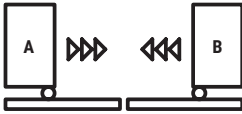

Two opposing sliding gate automation system may be connected to a single **H70/104AC-H70/105AC** control unit.
 Connect the control units together using third party 24 V $\overline{\text{---}}$ relays (not supplied by ROGER), as indicated in the figure.

A single radio board, installed in one of the two control units (**A** or **B**) may be used. Use the output **COR** to manage radio control signals. Set the parameter **16** to **05**.

Check that both motors have the same firmware version.

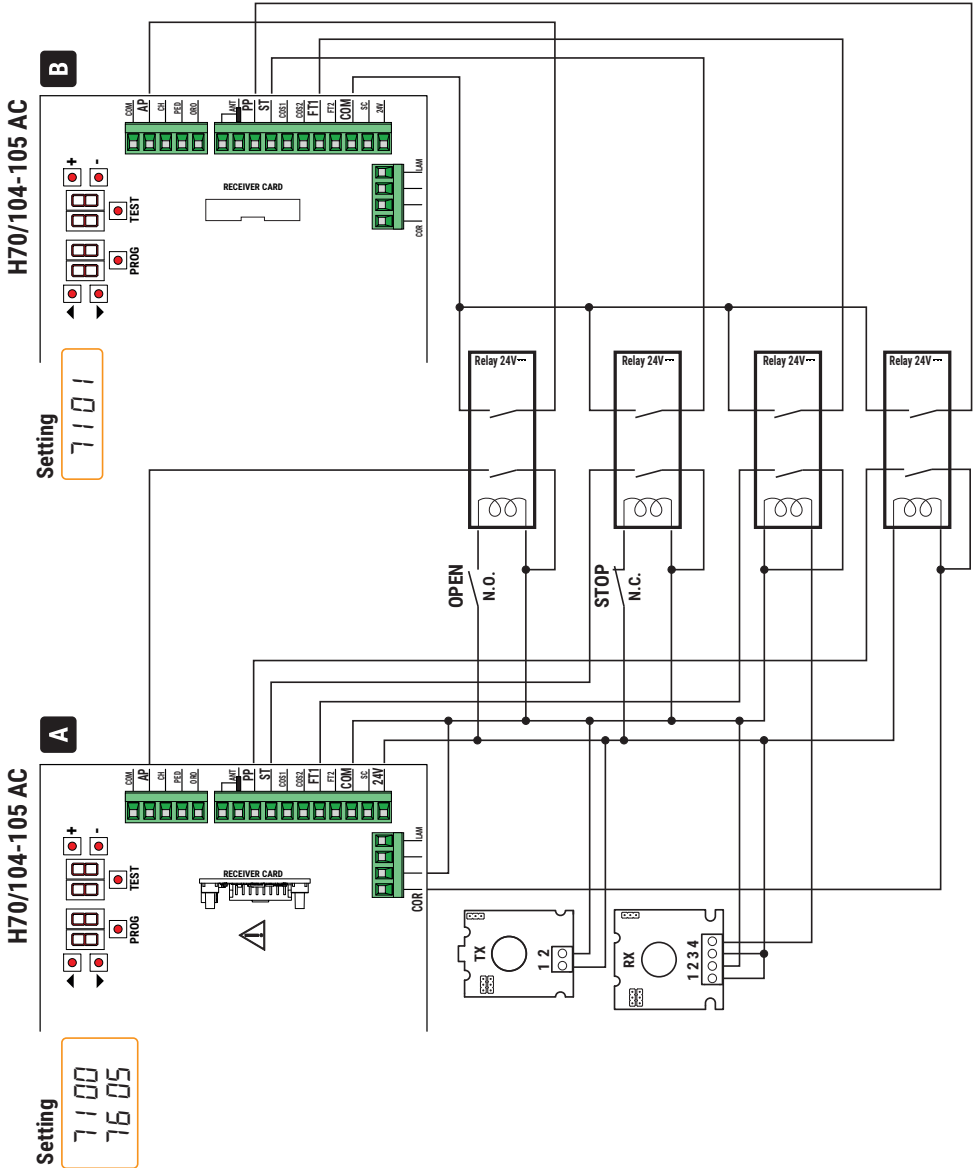

14 Safety input and command status (TEST mode)

With no currently active commands, press the TEST button and check the following:

DISPLAY	POSSIBLE CAUSE	ACTION BY SOFTWARE	PHYSICAL CORRECTIVE ACTION
BB 5b(Sb)	The release handle is open.	-	Close the release handle and turn the key to the close position. Check that the release contact is connected correctly.
BB 18	The safety STOP contact is open.	-	Install a STOP button (NC) or jumper the ST contact with the COM contact.
BB 17	Sensing edge COS1 not connected or incorrectly connected.	Set the parameter 73 00 if not used or to disable	Jumper contact COS1 with contact COM , if not used or to disable
BB 16	Sensing edge COS2 not connected or incorrectly connected.	Set the parameter 74 00 if not used or to disable	Jumper contact COS2 with contact COM , if not used or to disable
BB 15	Photocell FT1 not connected or incorrectly connected.	Set the parameter 50 00 e 5 1 00 if not used or to disable	Jumper contact FT1 with contact COM , if not used or to disable. Check connection referring to relative connection diagram (fig. 9).
BB 14	Photocell FT2 not connected or incorrectly connected.	Set the parameter 53 00 e 54 00 if not used or to disable	Jumper contact FT2 with contact COM , if not used or to disable. Check connection referring to relative connection diagram (fig. 9).
BB FE	Both limit switches in open contact state or not connected.	-	Check connection of limit switches.
BB FA	Gate is at gate closed limit switch.	If the limit switch state indicated is incorrect, check the setting of parameter 7 I.	-
	Gate open limit switch absent or not connected.	-	Check connection of limit switches.
BB FC	Gate is at gate closed limit switch.	If the limit switch state indicated is incorrect, check the setting of parameter 7 I.	-
	Gate closed limit switch absent or not connected.	-	Check connection of limit switches.
PP 00	If occurs with no voluntary command, the contact (N.O.) may be faulty or one of the buttons may be incorrectly connected.	-	Check PP - COM contacts and connections to buttons.
CH 00		-	Check CH - COM contacts and connections to buttons.
AP 00		-	Check AP - COM contacts and connections to buttons.
PE 00		-	Check PED - COM contacts and connections to buttons.
Or 00	If occurs with no voluntary command, the contact (N.O.) may be faulty or the timer may be incorrectly connected.	-	Check ORO - COM contacts. Contact must not be jumpered if not used.

N.B.: Press **TEST** button to exit from the **TEST** mode.

We recommend troubleshooting safety device and input status errors with "corrective action by software" only.

15 Alarms and faults

PROBLEM	ALARM	POSSIBLE CAUSE	ACTION
The gate does not open or close.	POWER LED off	No power.	Check power cable.
	POWER LED off	Fuse F1 blown.	Replace fuse. Always disconnect from mains power before removing fuses.
	POWER LED off	Overload on 24V $\overline{=}$ supply	Check the connections to the SC terminal
	Example: 15 EE 2 1 EE 54nC	Configuration parameter error. Fault in the mains synchronism extraction	Set configuration value correctly and save. Contact service
Acquisition procedure does not complete correctly.	AP PE	TEST button pressed accidentally.	Repeat acquisition procedure.
		Safety devices in alarm state.	Press the TEST button and check the safety device/s in alarm state and the connections of the safety devices.
Remote control has limited range and does not work while automated gate is moving.	-	The radio transmission is impeded by metal structures and reinforced concrete walls.	Install the antenna outside.
	-	Flat batteries.	Replace the transmitter batteries.
The flashing light is not working.	-	Bulb / LED blown or flashing light wires disconnected.	Check LED circuit and/or connector wires.
Gate open indicator lamp does not work.	-	Bulb blown or wires disconnected.	Check the bulb and/or wires.
Gate does not perform desired manoeuvre.	-	Motor leads crossed.	Swap two wires on terminal X-Y-Z or Z-Y-X.

N.B.: Press the TEST button to temporarily cancel the alarm.

The next time a command is received, the alarm reappears on the display if the problem has not been resolved.

16 Mechanical release (H70/104AC only)



In the event of power failure, the gate may be unlocked by following the instructions given in the use and maintenance manual of the H30, M30, G30, E30 or R30 automation system. On receiving the first command signal after mains power is restored, the control unit starts an opening manoeuvre in position recovery mode (chapter 17).

Position recovery is performed immediately when the limit switches (if installed) are activated.

17 Position recovery mode

When it receives the first command signal after a power failure, after unlocking the motor or after an obstacle is detected in the same position three consecutive times (with encoders enabled), the control unit starts a manoeuvre in position recovery mode.

If encoder is installed the manoeuvre in position recovery mode happens at low speed; otherwise the manoeuvre happens at normal speed. The flashing light flashes with a different duty cycle than normal (3 s on, 1.5 s off).

The control unit recovers the installation data during this procedure.

Warning! Do not use any controls until the gate has completed the opening and closing manoeuvre.

Position recovery is performed immediately when the limit switches (if installed) are activated.

18 Initial testing



The testing must be performed by qualified technical personnel.

The installer is required to measure impact forces and select on the control unit the appropriate speed and torque values to ensure that the motorised door or gate remains within the limits defined by the standards EN 12453 and EN12445.

Make sure that the provisions in "GENERIC WARNINGS" are observed.

- Turn on the power supply.
- Check that all connected controls are working correctly.
- Check travel and deceleration.
- Check that the safety devices are activated correctly
- Disconnect from mains power then reconnect. Check that the position recovery procedure is completed correctly.
- Check the limit switch settings (if installed).
- Check that the release system works correctly (**H70/104AC only**).

19 Start-up

The installer is required to draw up and preserve the technical file of the system for at least 10 years, which must contain the wiring diagram, the drawing and the photo of the system, the risk analysis and the solutions adopted, the manufacturer's declaration of conformity for all connected devices, the instructions manual of each device and / or accessory and the system's maintenance plan.

Apply a plate indicating the automation system data on the motorised door or gate, the name of the person in charge of the start-up, the serial number and the year of construction, as well as the CE mark.

Apply a plate and / or label with the indications for the operations required to manually unlock the system.

Draw up and provide the end user with the declaration of conformity, instructions and warnings for use and the maintenance plan.

Make sure that the end user has understood the correct automatic, manual or emergency operation of the system.

Inform the end user about the dangers and risks that may be present.

Declaration CE of Conformity

The undersigned Dino Florian, legal representative of **Roger Technology - Via Botticelli 8, 31021 Mogliano V.to (TV)** DECLARES that the **H70/104AC - H70/105AC** digital control unit is compliant with the provisions established by

Community directives:

- 2014/53/UE RED Directive

- 2011/65/UE RoHS Directive

and that all the standards and/or technical requirements indicated as follows have been applied:

IEC 61000-6-3:2020

IEC 61000-6-2:2016

EN IEC 61000-6-3:2021

EN IEC 61000-6-2:2019

EN 60335-1:2012 + AC:2014 + A1:2019 + A11:2014 + A13:2017 + A14:2019 + A2:2019 + A15:2021 + A16:2023

ETSI EN 301 489-1 V2.2.3

ETSI EN 301 489-3 V2.1.1

EN 62233:2008 + AC:2008

Place: Mogliano V.to

Date: 07/10/2024

Signature